



Sectional directional control valve

ECS12A

Rev. 04 • September, 2024

TECHNICAL CATALOGUE

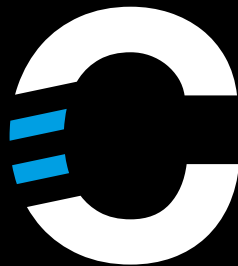

.....
Controls



HISTORY OF REVISIONS

DATE	PAGE	CHANGED	REV.
December, 2018	-	First edition	00
November, 2019	13-14-15-29-30-32-40-42	Updated hydraulic diagrams and note addition of T2 drain line	01
November, 2020	15-18-32-38-40	Hydraulic schema and dimensional drawing replaced. Information added on page 38	02
September, 2023	31-32-34-35-45	Float version inserted. Auxiliary valve V59 type added. Joystick control actuation added. Outlet with PRV and BPU inserted.	03
September, 2024	52-53-54-55-56	Spare parts list added	04

ABOUT THE MANUAL

This manual contains the technical instructions for the control ESC12A.
All information given in this manual is current and valid according to the information available at the time of publication.
The data specified above only serve to describe the product. EBC Motion controls reserves to modify or revise the instructions without prior notice.

EBC Motion controls is not responsible for any damage caused by an incorrect use of the product.
Please visit www.ebimc.com for the most recent version of this manual.

CONTENTS

4	INTRODUCTION
5	GENERAL INFORMATION
6	QUICK REFERENCE GUIDE
7	APPLICATION AND SAFETY GUIDELINES
10	HYDRAULIC FLUID
12	PORT DETAILS
13	DIMENSIONS
16	TECHNICAL SPECIFICATIONS
	TECHNICAL DATA
17	TYPICAL CURVES
18	CIRCUITS
19	ORDERING CODES
	ASSEMBLY SECTION
	INLET SECTION
	WORK SECTION
	OUTLET SECTION
	OPTION
	ACCESSORIES
	GENERAL CLAMPING TORQUE
52	SPARE PARTS LIST

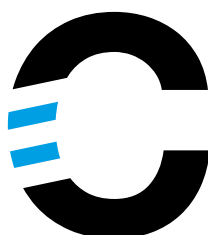

INTRODUCTION

CONTROLS

EBC motion controls provides a broad choice of directional control valves expertly developed and tested to meet different market sectors' needs. EBC Control valves are suited for specialized applications for a variety of mobile equipment such as:

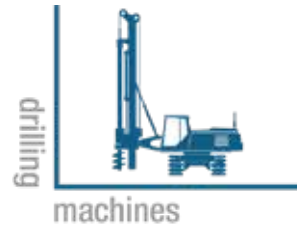

ECS12A

SECTIONAL DIRECTIONAL CONTROL VALVE

- From 1 to 12 working sections.
- Parallel and tandem circuit available.
- Low internal leakage.
- Compact directional valve with low pressure losses.
- Interchangeable spools.
- Wide range of auxiliary valves on the ports.
- Availability of manual, hydraulic, and electrohydraulic actuations.

GENERAL INFORMATION

HYDRAULIC OPERATING PRINCIPLE

Directional control valve ECS12A basically comprises of an inlet section, directional valve sections and an outlet section. It is designed to the 6-way principle and comprises of an arrangement body (1), control spool (3), load holding check valve (2), actuation spool (4), return action spool (5), cavities for the secondary pressure valves or relief/anti-cavitation valves (6), as well as anti-cavitation valves or plug (7).

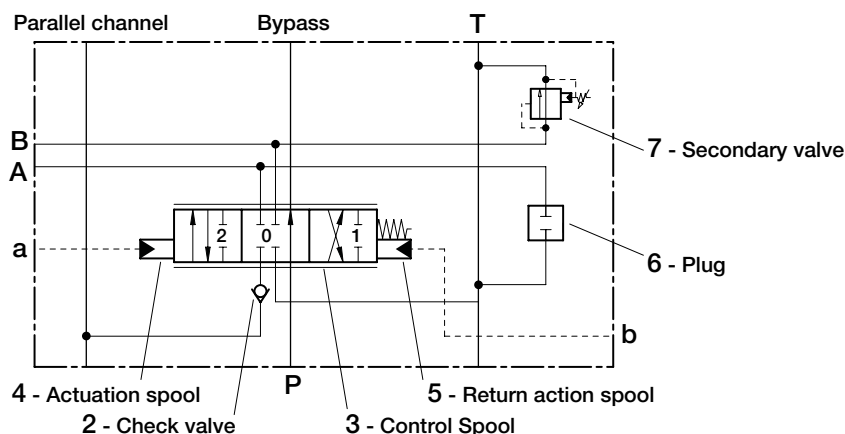

With all of the spool axes in their neutral position the flow passes via the bypass channel at zero pressure to tank. If one of the control spools is actuated then the connection from the pump to the actuator is opened via the fine control grooves, whilst the bypass is throttled by fine control grooves. If the pump pressure exceeds the actuator pressure, the pressure fluid starts to flow over the check valve to the actuator.

With further movement of the control spool the volume of fluid is increasingly diverted from the bypass channel to the actuator (fine control). The spool stroke is divided into three phases: overlap (leak-free in the neutral position), fine control range (flow and pressure), residual stroke (fully open).

Due to the large fine control range of the spool stroke it is possible to sensitively control the actuators.

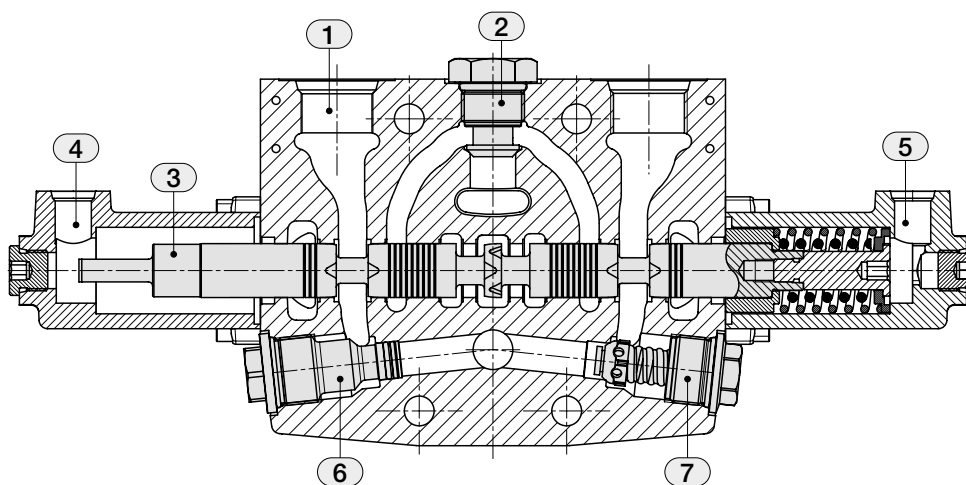

Section ECS12A with hydraulic actuation and fixed setting combined valves.



QUICK REFERENCE GUIDE

TYPE	ECS08A	ECS10A	ECS12A
Number of sections	1-12	1-12	1-12
Parallel circuit	•	•	•
Tandem circuit	•	•	•
Parallel circuit stroke (mm) - [in]	6 [0.24]	7 [0.28]	8 [0.32]
Float spool extra stroke (mm) - [in]	5 [0.20]	4.5 [0.18]	6 [0.24]
Spool pitch (mm) - [in]	36 [1.42]	41 [1.62]	48 [1.89]
Spool diameter (mm) - [in]	14 [0.55]	16 [0.63]	19 [0.75]
Nominal flow (l/min) - [GPM]	50 [12]	100 [25]	150 [40]
Operating pressure (bar) - [psi]	350 [5000]	350 [5000]	350 [5000]
OPTION CHART	ECS08A	ECS10A	ECS12A
Pilot operated pressure relief valve	•	•	•
Solenoid dump valve 12 VDC	•	•	•
Solenoid dump valve 24 VDC	•	•	•
Main anticavitation check valve	•	•	•
SPOOL ACTUATION	ECS08A	ECS10A	ECS12A
Manual actuation	•	•	•
Hydraulic actuation	•	•	•
Electrohydraulic actuation	•	•	•
SPOOL RETURN ACTION	ECS08A	ECS10A	ECS12A
3 positions spring centered	•	•	•
Pneumatic control	•	•	•
Detent in position 1/2 - 1 - 2	•	•	•
Detent in 4 th position	•	•	•
AUXILIARY VALVES	ECS08A	ECS10A	ECS12A
Fixed setting combined valve	•	•	•
Fixed setting anticavitation valve	•	•	•
Adjustable pilot combined valve		•	•

APPLICATION AND SAFETY GUIDELINES

INTENDED USE

Directional control valve ECS12A is designed for mobile applications.

WARRANTY

Check the package and the product for transport damage when receiving goods. The package is not meant for long term storage; protect the product appropriately. Do not dismantle the product. The warranty is void if the product has been disassembled. The manufacturer is not responsible for damages resulting from misinterpreted, non compliance, incorrect, or improper use of the product that goes against the instructions given in this document.

GENERAL SAFETY INSTRUCTIONS

The following instructions apply to all procedures associated with the product. Read these instructions carefully and follow them closely.

- Use necessary personal protective equipment when working with the product.
- Support the product properly; make sure the product cannot fall over or turn around by accident.
- Use only appropriate equipment and attachments for lifting and transferring the product.
- Prevent unintended use of the product during installation and maintenance procedures.
- Never use the Control Valve at a pressure exceeding the rated pressure.
- Use the Control Valve within the rated flow; if not there might be malfunction or a deterioration in heat balance.
- Using low-cleanliness hydraulic fluid might cause seal failure or damage to the seal part, resulting in operation failure, or operation mistake of the machine; the customer is requested to check the cleanliness of the hydraulic fluid.

WARNING SYMBOL

The following symbols can be used in this manual:



Note:
Useful
information



Danger:
Danger of death
or injury



Attention:
May cause damage
to the product

STORAGE OF NEW PRODUCT

Encapsulated by a protective wrapping, the control valve ECS12A shall not be exposed to direct sunlight nor to source of heat or ozone and kept in a dry place at a temperature between -20°C +50°C [-4°F +122°F].

Do not store the product in:

- Places where it might be damaged;
- Very hot/humid areas;
- Where it could get wet;
- Where it could come into contact with organic solvents, acids, alkalis and/or dangerous gases;
- In places subject to sudden, significant changes in temperature.

EBI motion control is not responsible for any damages due to a storage not in compliance with our prescriptions; For any doubts, please contact our aftersales office.

SAFETY GUIDELINES

During any operation on product ECS12A, it is recommended to pay attention to components surfaces temperature. The circuit functions are to be so designed that uncontrolled machine movements, caused by the application, are prevented and that it is possible to switch from one function to another. Take into account all of the application limits, particularly those application limits stated within this technical catalogue.

It is recommended to follow these steps and only trained and competent personnel may carry out any work on ECS12A Control Valve:

- Do not direct the jet of a pressure washing unit directly to the product
- Ensure that all matching surfaces are clean, without contamination.



- Ensure that all seals and back-up rings for the matching surfaces are flawless and correctly placed.
- Do not put any sealing material other than the standard seals.
- During the assembly of the complete Control Valve, refer to the hydraulic scheme and to the name assigned to each port.
- Use gloves in order to avoid accidental injuries during installation or maintenance.
- Do not grab / handle product from moving parts (i.e. cables, levers,...etc.)
- All Control Valve are attributable to pressure vessels. It's always recommended to place the components in a closed but ventilated compartment, able to protect the environment and users in case of accidental ejection of material under pressure (fittings, pipes, plugs, expander,...etc.)
- Before removing or disassembling the complete Control Valve or allowed parts (as pressure gauge ports, plugs) it is strongly recommended to vent all hydraulic pressure from the system.
- During the first start of the machine, please ensure that the grounding system is connected and stay away from moving parts.

HANDLING PRECAUTIONS

If the Control Valve doesn't work in the adequate way, we advise you to contact our aftersales Office. However if the disassembly and assembly operations are strictly unavoidable, you must observe the following prescriptions and charge the carrying out of the operations to technicians high qualified in hydraulic field.

- The Control Valve reaches high temperature after operating the machine; start the work only after checking that the temperature is low;
- The valve can hold high internal pressure; release the inside pressure and ensure all machine actuators are in a rest position before removing the piping. In any case safely and carefully unscrew connections and fittings.
- Since hydraulic devices are all machined precisely with very accurate clearances, carry out the disassembly adassembly work at a clean place;
- Before disassembly work, get the assembly instructions by requiring to our aftersales office and prepare all the material needed for the task;
- To disassemble and assemble the valve observe strictly our mounting instructions;
- Since there is the possibility of rust when the disassembled parts are left, apply anticorrosive oil to the parts and seal them;
- Before remounting the Control Valve on the operating machine, ensure that the Control Valve has not been affected by carrying out various hydraulic tests (e.g. Relief Valve setting, Leak test..).



Attention:

Always bear in mind that "all workers must act responsibly to ensure their own health and safety"; use of personal protection equipment is therefore essential. All the disassembly and assembly operations must observe strictly the procedures listed in the EBI procedures. EBI motion control is not responsible for any damages due to disassembly and assembly procedures not in compliance with our prescriptions. For any doubts, please contact our aftersales department.

INSTALLATION PROCEDURES

On receiving the Control Valve make sure you:

- Check if there are some sign of damage of the packaging;
- Check that the dimensions of the product seat are compatible with those of the product itself;
- Remove the plastic caps that protect the service ports and be careful not to introduce any dirt or foreign matters inside the control valve as this could damage it;
- Mount the control valve securely to a flat surface (recommended 3 point fixing); at the time do not use a hammer to positioning by hitting; any distortion in assembly can result in spool sticking and poor control;
- Clean piping materials sufficiently before use;
- Prevent the port openings from being entered with dust or foreign matters;
- tighten the port connectors surely with the recommended fastening torques;
- If possible, install the valve in a protected environment, avoiding direct exposure to weathering, water, salt or any other corrosion substances.

FITTINGS TIGHTENING TORQUE (Nm)

Do not tighten fittings with torque more than the recommended value; If not there might be strains or damage to Control Valve so as to cause a serious accident.

If the pipings are not connected to the correspondent ports, unintentional movements might cause a serious accident; EBI motion control is not responsible for any damages due to an installation procedure not in compliance with our procedures.

SPECIFICATIONS	PORT (P)		PORT (A-B)	PORT (T)
BSP THREADS ISO 1179-1	G 3/4	G 1	G 3/4	G 1
<i>with rubber sealing (DIN 3869)</i>	120 Nm	150 Nm	120 Nm	150 Nm
<i>with copper or steel and rubber washer</i>	120 Nm	150 Nm	120 Nm	150 Nm
UN/UNF THREADS ISO 11926-1	1"1/16 12 UNF	1"5/16 12 UNF	1"1/16 12 UNF	1"5/16 12 UNF
<i>with o-ring</i>	120 Nm	120 Nm	120 Nm	120 Nm

UNITS OF MEASURE - CONVERSION FACTORS

LENGHT	FLOW RATE	MASS	FORCE WEIGHT	PRESSURE
1 mm = 0,0394 in	1 l = 0,2200 gal UK	1 kg = 2,205 lb	1 Nm = 0,1020 Kgf	1 bar = 100000 Pa
1 in = 25,4 mm	1 l = 0,2642 gal US	1 lb = 0,4536 kg	1 Kgf = 9,8067 Nm	1 bar = 14,5 psi
	1 gal UK = 4,546 l			1 Pa = 0,0001 bar
	1 gal UK = 1,2010 gal US			1 Pa = 0,00014 psi
	1 gal US = 3,785 l			1 psi = 0,0689 bar
	1 gal US = 0,8327 gal UK			1 psi = 6890 Pa

PRODUCT IDENTIFICATION

The product identification data can be found on the identification plate attached to the EBI product.

SERIAL NUMBER

all manufacturing data and all sales data can be found with the serial number

PART NUMBER CODE

It is a number univocally identifying the configuration and pressure setting of a valve



Note:

Serial number and part number code have 9 characters (letters and numbers).

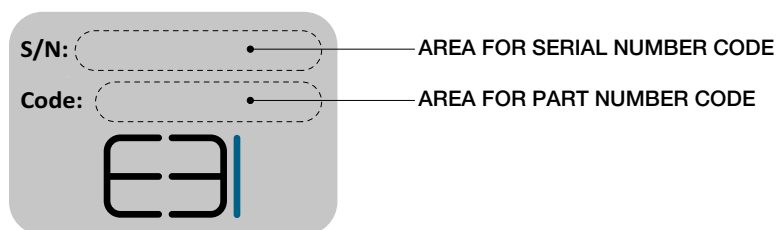

Attention:

These guidelines are not intended to be considered as complete



HYDRAULIC FLUID

Mineral oil based hydraulic fluids suitable for hydraulic systems can be used; they should have physical lubricating and chemical properties as specified by:

MINERAL OIL BASED HYDRAULIC FLUIDS HL (DIN 51524 part 1)

MINERAL OIL BASED HYDRAULIC FLUIDS HLP (DIN 51524 part 2)

For use of environmentally friendly fluids (vegetable or polyglycol base), or other fluids, please contact EBC.

OIL AND SOLUTIONS - ISO 6743/4	(°C) MIN	(°C) MAX
Mineral Oil HL, HM or HLP	-25	+80
Oil in water emulsion HFA	+5	+55
Oil in water emulsion HFB	+5	+55
Polyglycol-based aqueous solution HFC	-10	+60

Hydraulic fluids are available in different viscosity classes identified by the ISO VG number, which corresponds to the kinematic viscosity at 40°C. Here is a table showing typical viscosity changes between 0°C and 100°C for mineral oil based fluids having various viscosity classes. The fluid should be selected with the aim to achieve an appropriate operating viscosity at the expected working temperature.

Viscosity class	VISCOSITY CLASS AND FILTRATION DATA		
	kinematic viscosity (cSt)		
	maximum (0° C)	medium (40° C)	minimum (100° C)
ISO VG 10	90	10	2.4
ISO VG 22	300	22	4.1
ISO VG 32	420	32	5.0
ISO VG 46	780	46	6.1
ISO VG 68	1400	68	7.8
ISO VG 100	2560	100	9.9

FLUID CLEANLINESS REQUIREMENTS

The cause of malfunctions in hydraulics is often found to be excessive fluid contamination. The hard contaminant particles in the fluid wear the hydraulic components and prevent the poppets from re-seating, with consequent internal leakage and system inefficiency. For the correct operation it is necessary to adopt filtration methods which guarantee for life the specified fluid cleanliness level. It is important to ensure that hydraulic fluids are brought to the appropriate cleanliness level prior filling up the systems, and, when in doubt, also to flush the hydraulic components prior to installation.

FILTRATION RATIO $BETA_x$:

It is the ratio between the number of particles before and after the filter with diameter larger than X micron.

ABSOLUTE FILTRATION RATIO ISO 4572:

It is the diameter X of the largest particle with $BETA_x \geq 75$.

CONTAMINATION CLASS ISO 4406:

It is expressed by 3 scale numbers representing respectively: the number of particles equal to or larger than 4µm, the number of particles equal to or larger than 6µm, the number of particles equal to or larger than 14µm contained in 1 ml of fluid.

CONTAMINATION CLASS NAS 1638:

It is expressed by one scale numbers representing the number of particles of different size ranges contained in 1 ml of fluid.

FILTRATION RECOMMENDATION				
Type	Nominal filtration (micron)	Absolute filtration rating ISO 4572 (BETA _{x≥75})	Contamination class	
			ISO 4406	NAS 1638
System/components operating at <i>MEDIUM HIGH PRESSURE</i> <i>HIGH DUTY CYCLE APPLICATIONS</i> Systems/components with <i>MODERATELY dirt tolerance</i>	15	X = 12... 15	20/18/15	9



Attention:

If the filtration demands are not met, the valve poppets can jam in the open position, with the result that the valve remains actuated. It is not possible to force back jammed poppets mechanically.



PORT DETAILS

The connection port size is indicated by an ordering code common for all EBI products. Following tables show all available connections.

BSP THREADS ISO 1179-1	D	C		B		A		CODE
	UNI-ISO 228	mm	in	mm	in	mm	in	
	G 1/4	13	0.51	19	0.75	1	0.094	1B
G 3/8	13	0.51	25	0.98	1	0.04	2B	
G 1/2	15	0.59	29	1.14	1.5	0.06	3B	
G 3/4	17	0.67	36	1.42	1.5	0.06	4B	
G 1	19	0.75	45	1.77	2	0.08	5B	

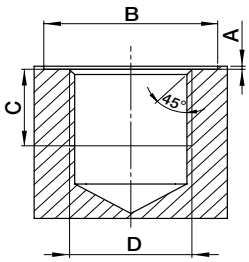

UN/UNF THREADS ISO 11926-1	D	C		B		L		M		K	A		CODE
	ASA-B1-1	mm	in	mm	in	mm	in	mm	in		mm	in	
	9/16-18 UNF (SAE6)	13	0.51	26	1.02	15.6	0.61	2.5	0.098	12°	1	0.04	1S
3/4-16 UNF (SAE8)	15	0.59	30	1.18	20.6	0.81	2.6	0.102	15°	1.5	0.06	2S	
7/8-14 UNF (SAE10)	17	0.67	34	1.34	23.9	0.94	2.6	0.102	15°	1.5	0.06	3S	
1"1/16-12 UNF (SAE12)	20	0.79	41	1.61	29.2	1.15	3.3	0.13	15°	1.5	0.06	4S	
1"5/16-12 UNF (SAE16)	20	0.79	50	1.97	35.5	1.40	3.3	0.13	15°	2	0.08	5S	

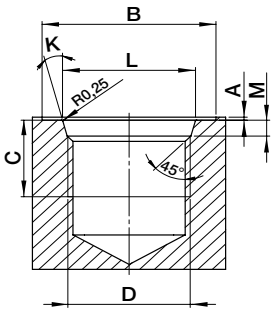

DIMENSIONS

ECS12A MECHANICAL ACTUATION

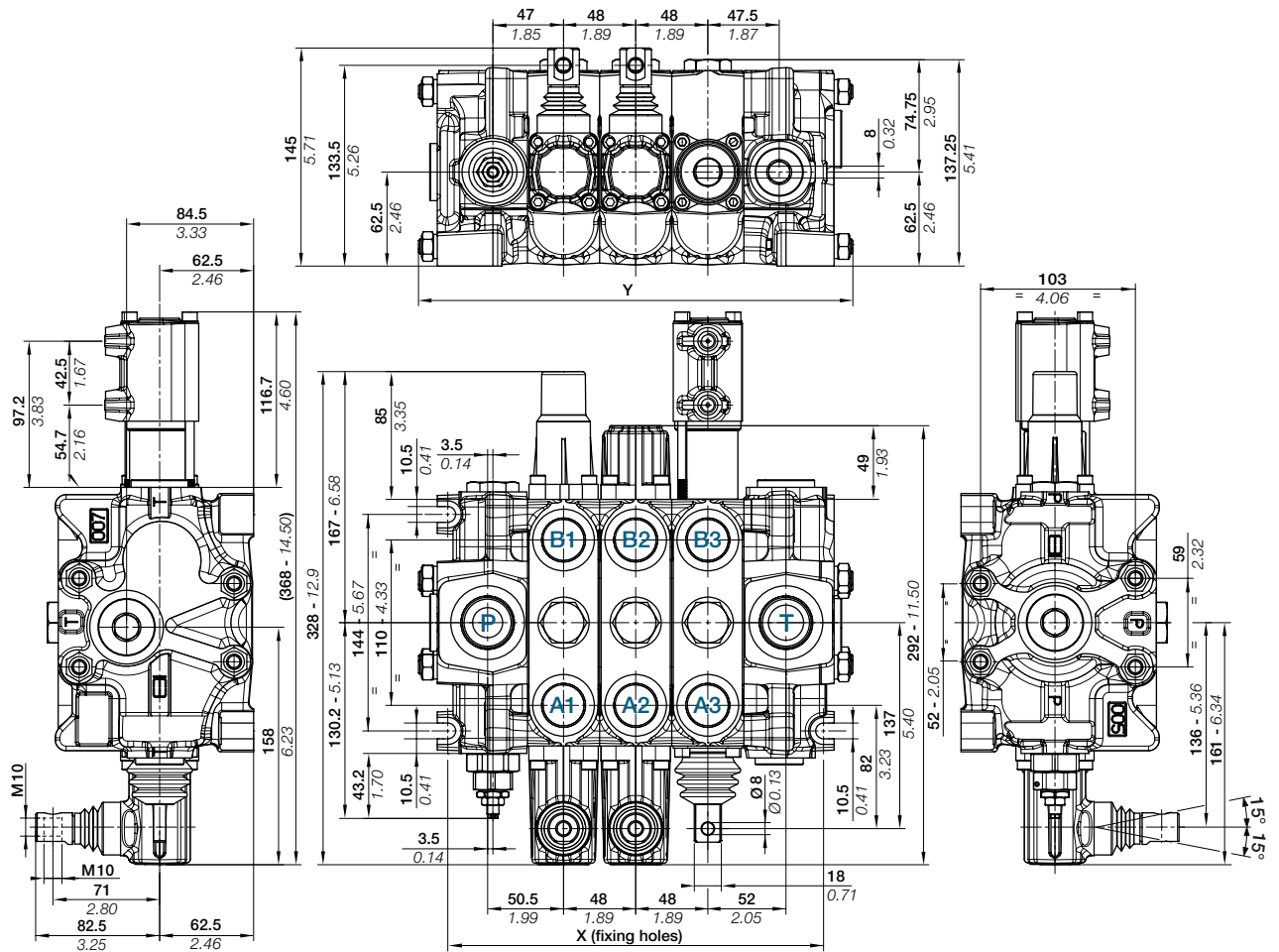

STANDARD CONNECTIONS

TYPE	BSP (ISO 1179-1)	UN-UNF (ISO 11926-1)
INLET - P	G 3/4	1"1/16-12 UNF (SAE12)
gauge connection	G 1/4	9/16" - 18 UNF (SAE6)
PORTS - A/B	G 3/4	1"1/16-12 UNF (SAE12)
OUTLET - T/T1	G 1	1"5/16-12 UNF (SAE16)
Pneumatic pilot	G 1/8	NPTF 1/8-27

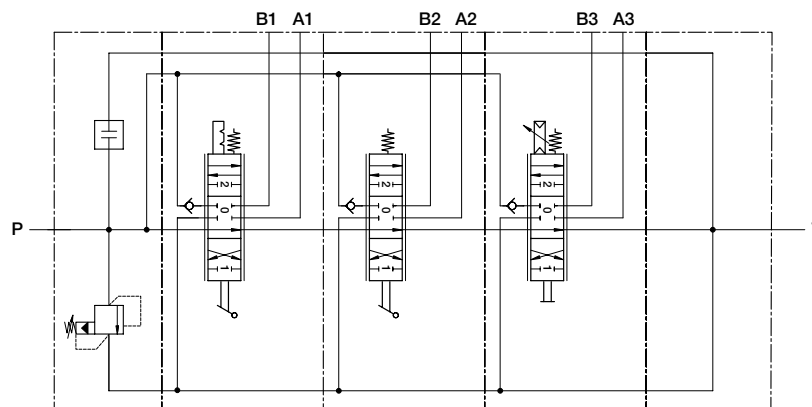

DIMENSIONS

ECS12A ELECTROHYDRAULIC ACTUATION

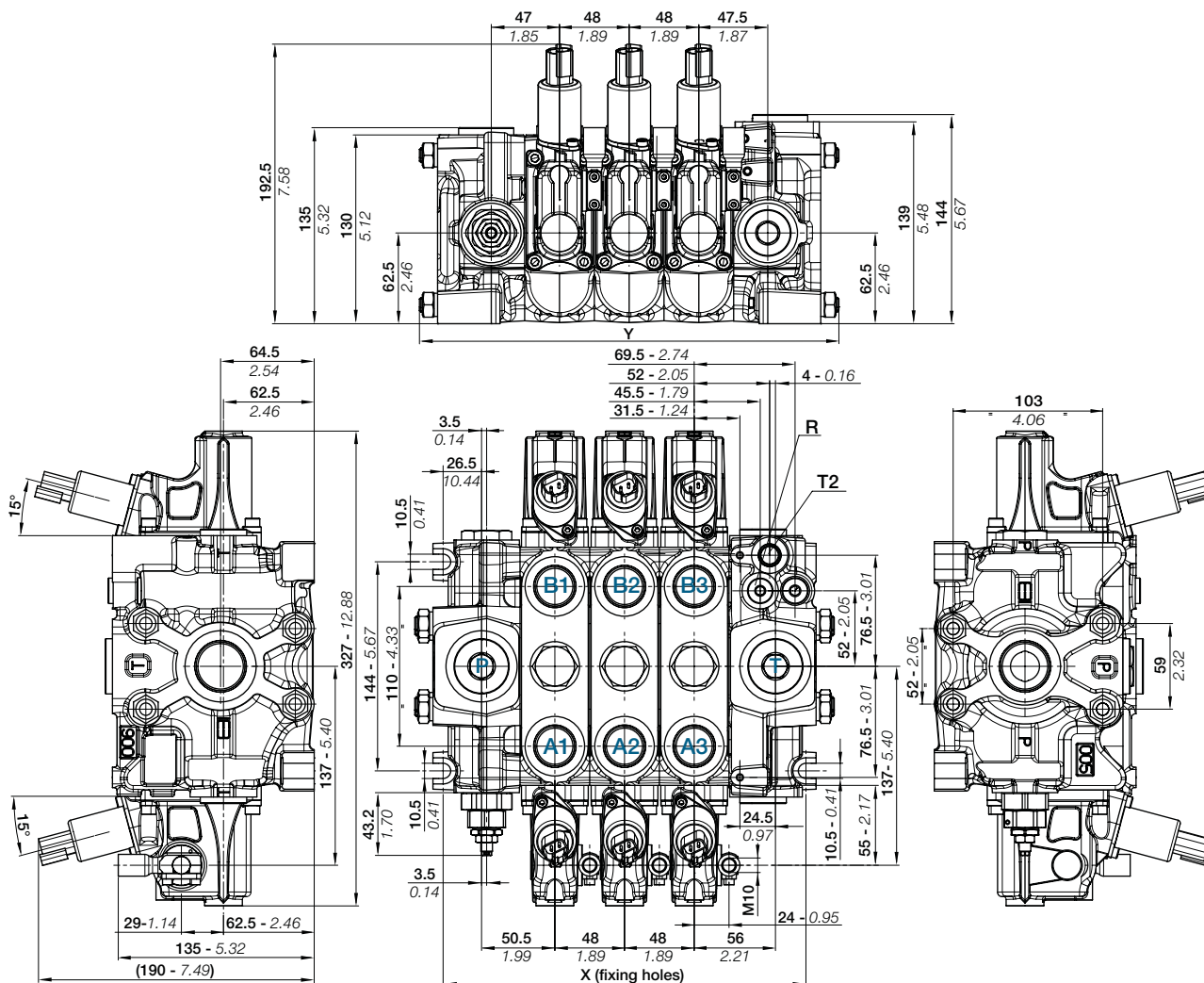

STANDARD CONNECTIONS

TYPE	BSP (ISO 1179-1)	UN-UNF (ISO 11926-1)
INLET - P	G 3/4	1"1/16-12 UNF (SAE12)
gauge connection	G 1/4	9/16" - 18 UNF (SAE6)
PORTS - A/B	G 3/4	1"1/16-12 UNF (SAE12)
OUTLET - T/T1	G 1	1"5/16-12 UNF (SAE16)



Note:

All outlet sections ECS12A for electrohydraulic configuration contain a pressure reducing valve (RDP).

We recommend to connect drain port T2 directly to tank, in order to avoid control system damages and inaccurate control.

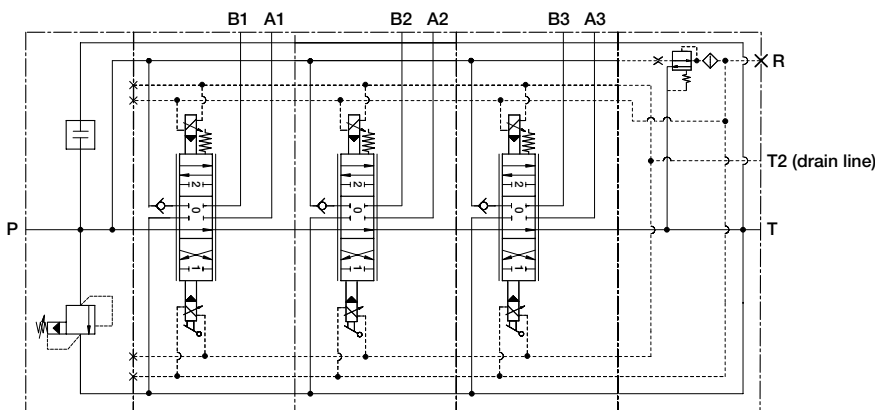



TECHNICAL SPECIFICATIONS

TYPE	X	Y	WEIGHT (mechanical version)	WEIGHT (electrohydraulic version)
	mm - [in]	mm - [in]	kg - [lb]	kg - [lb]
ECS12/1	154 - [6.07]	194 - [7.65]	18,6 - [41.0]	19,2 - [42.3]
ECS12/2	202 - [7.96]	242 - [9.54]	24,8 - [54.7]	25,4 - [56.0]
ECS12/3	250 - [9.85]	290 - [11.43]	31,0 - [68.4]	31,6 - [69.7]
ECS12/4	298 - [11.74]	338 - [13.32]	37,2 - [82.0]	37,8 - [83.3]
ECS12/5	346 - [13.63]	386 - [15.21]	43,4 - [95.7]	44,0 - [97.0]
ECS12/6	394 - [15.52]	434 - [17.01]	49,6 - [109.4]	50,2 - [110.7]
ECS12/7	442 - [17.41]	482 - [18.99]	55,8 - [123.0]	56,4 - [124.3]
ECS12/8	490 - [19.31]	530 - [20.88]	62,0 - [136.7]	62,6 - [138.0]
ECS12/9	538 - [21.20]	578 - [22.77]	68,2 - [150.4]	68,8 - [151.7]
ECS12/10	586 - [23.09]	626 - [24.66]	74,4 - [164.0]	75,0 - [165.3]
ECS12/11	634 - [24.98]	674 - [26.56]	80,6 - [177.7]	81,2 - [179.0]
ECS12/12	682 - [26.87]	722 - [28.45]	86,8 - [191.4]	87,4 - [192.7]

TECHNICAL DATA

All performances in this catalogue are obtained using mineral based hydraulic oil 46 cSt viscosity at 40°C (ISO VG 46 viscosity class). All ECS12A go through functional testing at these conditions before shipment.

HYDRAULIC STANDARD SPECIFICATIONS

Nominal Flow range	150 l/min - [40 GPM]
Nominal pressure	350 bar - [5000 psi]
Max back pressure (T line)	20 bar - [290 psi]
Hysteresis	< 1 bar - [14,5 psi]
Hydraulic fluid	Mineral Oil HL, HLP (DIN 51524); phosphate ester (HFD-R)
Fluid temperature range	-20°C +80°C [-4°F +176°F]
Fluid viscosity range	10 ÷ 380 cSt
Max contamination level	9 (NAS 1638) - 20/18/15 (ISO 4406:1999)
Recommended filtration	B10 > 75 (ISO 16889:20008)

MECHANICAL STANDARD SPECIFICATIONS

Spool return force (without detent)	90 ÷ 125 N (std spring)
Max actuation force on the spool (radial)	16 N

GENERAL STANDARD SPECIFICATIONS

Weight (inlet section)	6 Kg - 13 lbs
Weight (work section)	6,2 Kg - 13,6 lbs
Weight (outlet section)	6,4 Kg - 14 lbs
Weight (outlet section with reducing valve)	7 Kg - 15,4 lbs
Max number of sections	12

MATERIAL STANDARD SPECIFICATIONS SEALS

O-Rings: **Buna N** (acrylonitrile butadiene), also named **NBR** (according to ASTM), compatible with fluids having mineral oil base, water in oil emulsions, and water glycol fluids.

These seals are standard for temperatures within the range -20°C and +80°C

Back-up rings and Slide rings: **strengthened PTFE** (Politetrafluoroetilene like Teflon®, Lubriflon®, Ecoflon®, or similar). Special FPM (Viton®) seals are available on request.

Note: the seal materials are compatible with the fluids normally used in hydraulic systems; in case of special fluids, if you suspect incompatibility between the fluid used and the standard seals, contact the EBC motion controls service network.

TYPICAL CURVES

PERFORMANCE DATA - PRESSURE DROP (P-T)

Pressure characteristic as function of flow

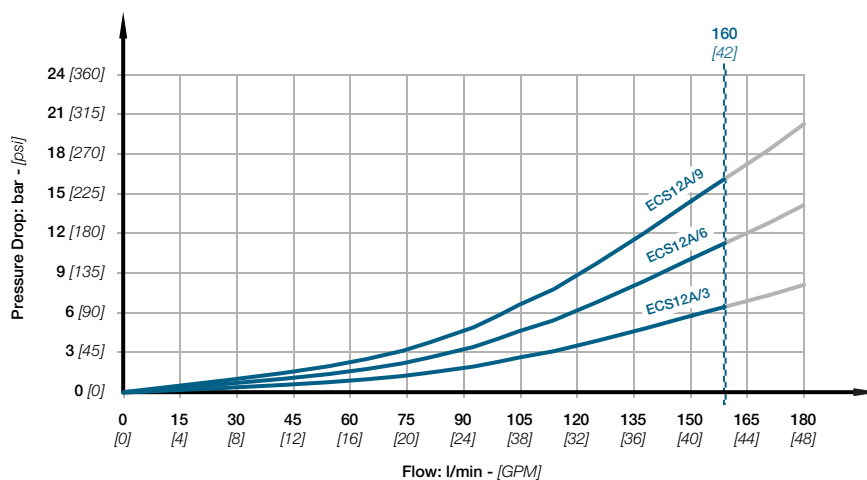

PERFORMANCE DATA - PRESSURE DROP (P-A/B)

Pressure characteristic as function of flow

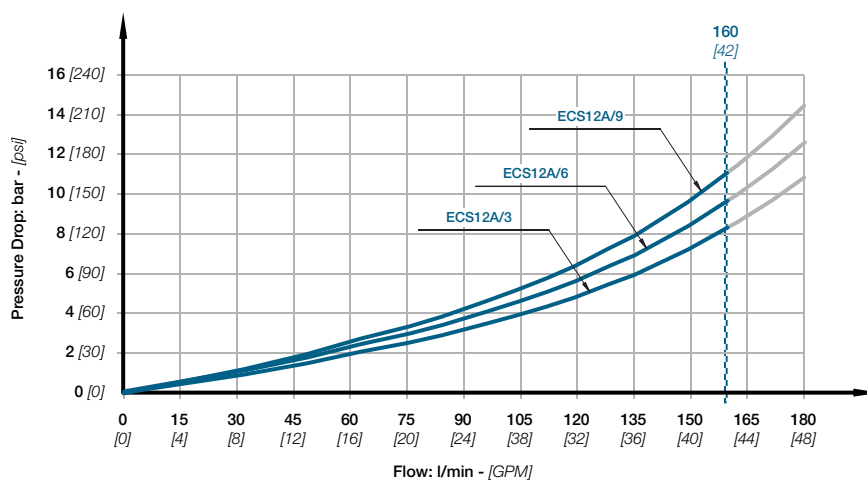

PERFORMANCE DATA - PRESSURE DROP (A/B-T)

Pressure characteristic as function of flow

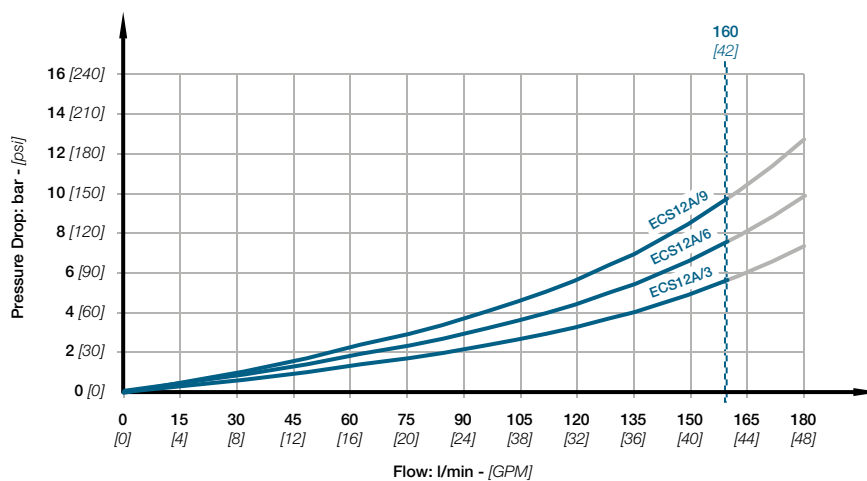

CIRCUITS

PARALLEL CIRCUIT: a number of actuators can be operated simultaneously

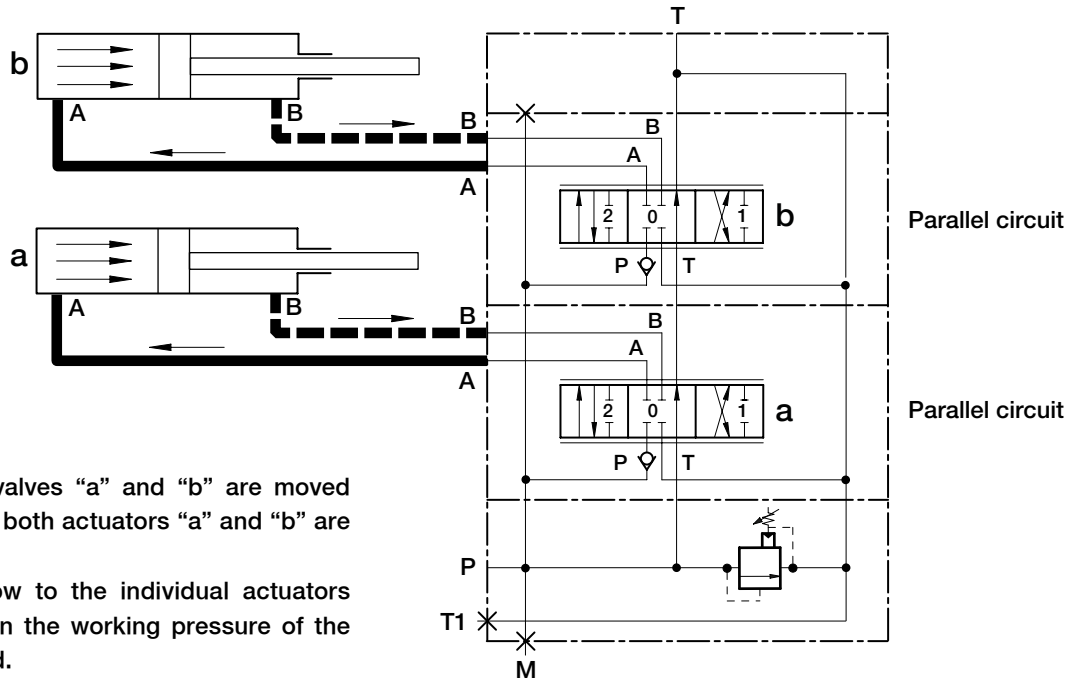

Example:

When directional valves “a” and “b” are moved to position 2 (or 1), both actuators “a” and “b” are operated.

The division of flow to the individual actuators is dependent up on the working pressure of the actuator concerned.

TANDEM CIRCUIT: only one actuator may be operated.

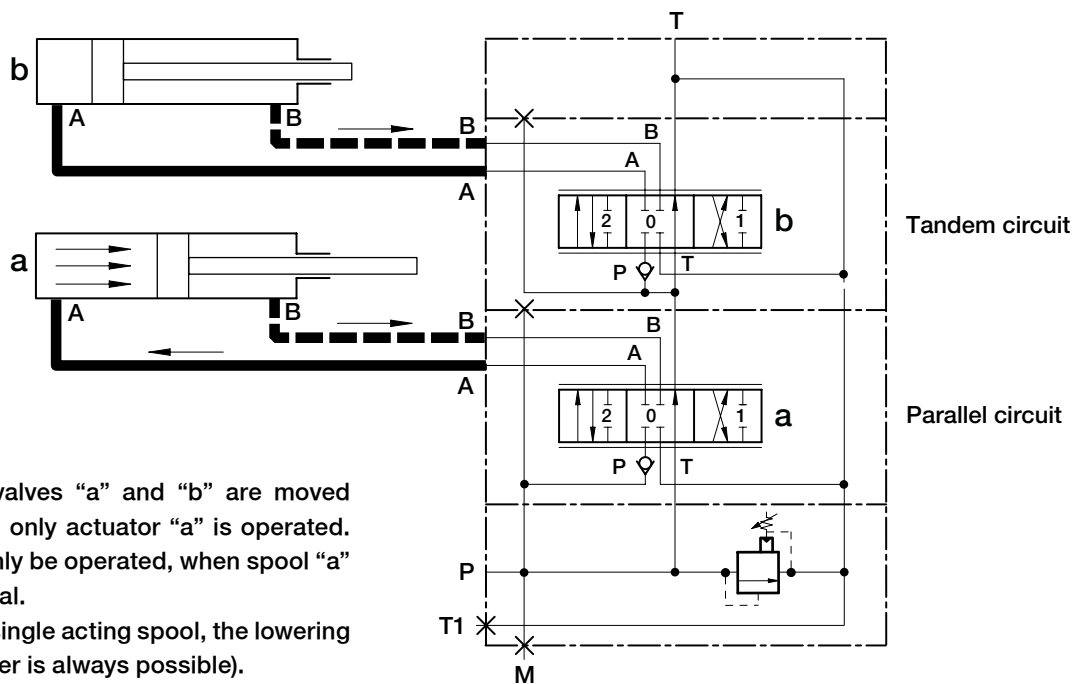

Example:

When directional valves “a” and “b” are moved to position 2 (or 1), only actuator “a” is operated. Actuator “b” can only be operated, when spool “a” is returned to neutral.

(Exception: with a single acting spool, the lowering action of the cylinder is always possible).

ORDERING CODES

The order code below provides an example of control ECS12A with standard configuration.

This example represents a ECS12A with single electrohydraulic section.

You can configure a ECS12A up to 12 work sections; ordering code in position 6, 7, 8, 9, 10, 11, 12 and 13 must be repeated for every work section.

info	product					1																													
	E	C	S	1	2	A	N	1																											
inlet section	2	3			4				5																										
	L	P	1	4	S	V	0	1	1	5	0	V	0	2																					
Work section	6	7				8				9		10		11		12		13																	
	L	S	1	P	2	E	4	S	V	5	1	1	0	0	V	5	1	1	8	0	S	0	1	N	A	E	0	1	R	E	0	1	K	1	2
outlet section	14	15																																	
	L	T	1	R	5	S																													
options	16																																		
	X	1																																	

	POSITION	CODE	DESCRIPTION	PAGE
info		ECS12A	Product	
	1	N1	Assembly section	22
Inlet section	2	L	Inlet side	23
	3	P14S	Arrangement body inlet	24
	4	V01150	Inlet valve on port 1	25
	5	V02	Inlet valve on port 2	
	6	L	Section side	27
work section	7	S1P2E4S	Arrangement section body	28
	8	V51100	Valve on port A	32
	9	V51180	Valve on port B	
	10	S01N	Spool	33
	11	AE01	Actuation kit	34
	12	RE01	Return action kit	38
	13	K12D	Solenoid kit	40
outlet section	14	L	Outlet side	41
	15	T1R5S	Arrangement outlet body	42
options	16	X1	Painted option	46



Note:

Ordering codes in position 2, 6 and 14 are always the same. Indicate the mounting side of the valve.



All sectional ECS12 valves have symmetric bodies; thanks to this characteristic, it is possible to change the control side, by simply reversing the spool 180°.
All valves can easily be changed from right inlet (R) to left inlet (L) and vice versa.
This example represents a valve in left configuration.

COMPLETE SECTIONAL VALVE ECS12A

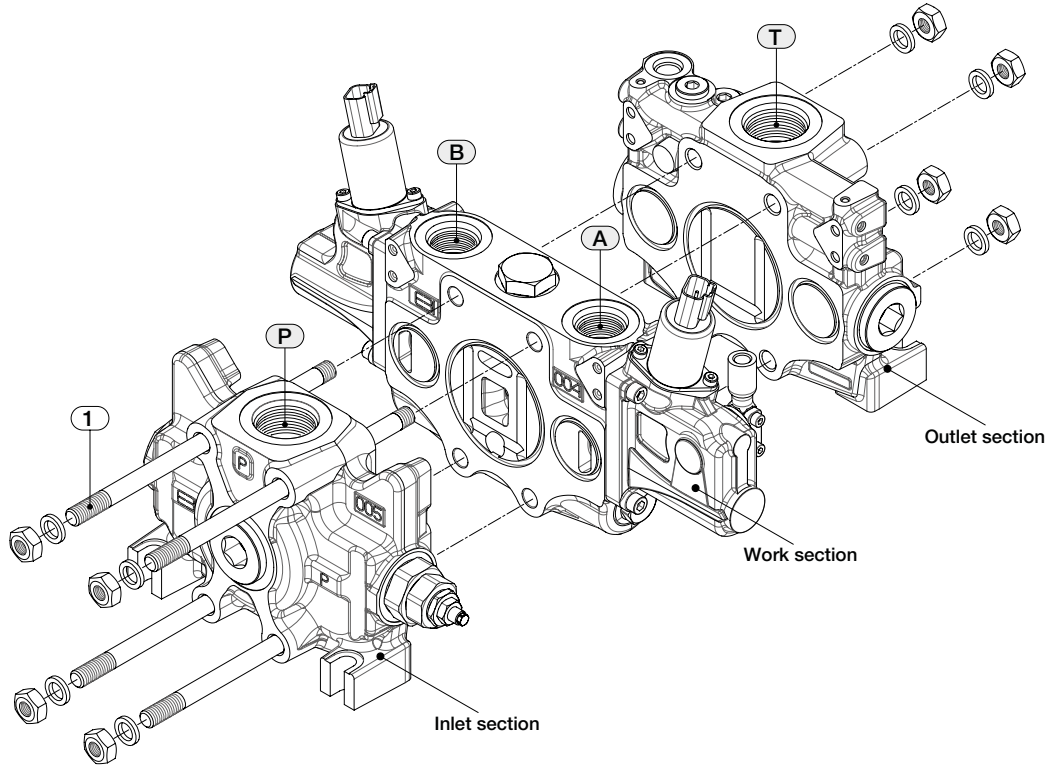

INLET SECTION

WORK SECTION

OUTLET SECTION

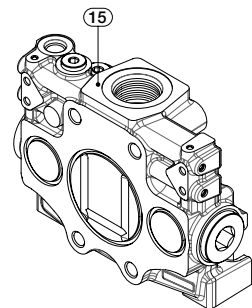
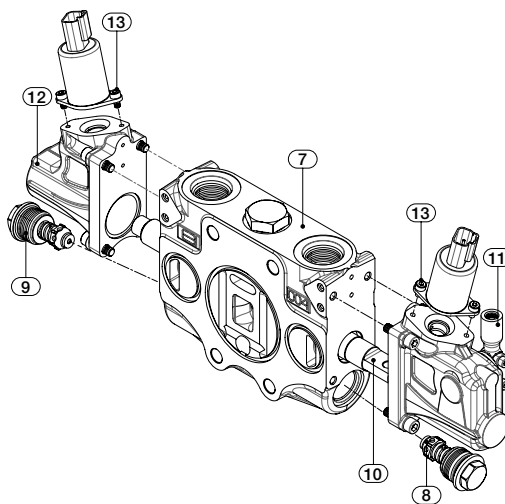
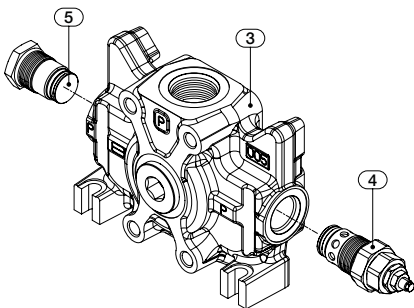

ASSEMBLY MODALITY FOR DIRECTIONAL CONTROL VALVE



Attention:

in the case of mixed configurations (section with electrohydraulic actuation and sections with mechanical or hydraulic actuation) it is mandatory to place all the electrohydraulic sections near to the outlet section. As a consequence all the mechanical or hydraulic sections will be positioned immediately after the inlet section.

EXAMPLE OF CONFIGURATION:

ECS12A/6 with 3 mechanical section and 3 electrohydraulic section: directional control valve with left inlet

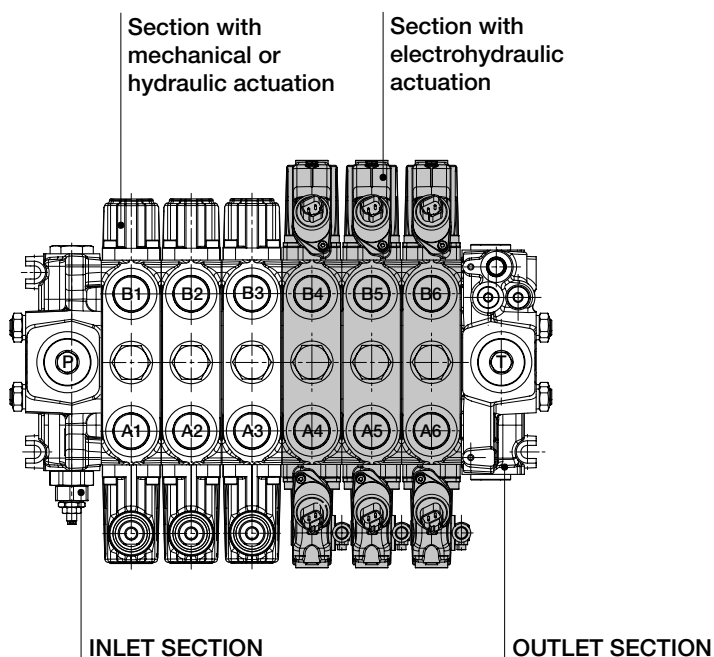

Note:

All mixed configurations are assembled with outlet section with RDP valve. Assembly modality also applies to directional control valve with right inlet.



Note:

For mixed configurations different from example, please contact our Sales Office.

ASSEMBLY SECTION

product						1
E	C	S	1	2	A	N1

Tie rod kit allows the correct assembly of directional sectional valves ECS12A.

Tie rod's length depends on the number of sections; each valve is assembled with tie rod kits including a tie rod, two nuts and two washer.

CODE	DESCRIPTION	LENGHT	CLAMPING TORQUE
N1	Assembly tie rod kit for single work section	194 mm - 7.644 in	40 Nm
N2	Assembly tie rod kit for 2 work sections	242 mm - 9.535 in	
N3	Assembly tie rod kit for 3 work sections	290 mm - 11.426 in	
N4	Assembly tie rod kit for 4 work sections	338 mm - 13.317 in	
N5	Assembly tie rod kit for 5 work sections	386 mm - 15.208 in	
N6	Assembly tie rod kit for 6 work sections	434 mm - 17.010 in	
N7	Assembly tie rod kit for 7 work sections	482 mm - 18.991 in	
N8	Assembly tie rod kit for 8 work sections	530 mm - 20.882 in	
N9	Assembly tie rod kit for 9 work sections	578 mm - 22.773 in	
N10	Assembly tie rod kit for 10 work sections	626 mm - 24.664 in	
N11	Assembly tie rod kit for 11 work sections	674 mm - 26.556 in	
N12	Assembly tie rod kit for 12 work sections	722 mm - 28.447 in	

This example represents ECS12A with one single work section; tie rod kit **N1**.



Note:

Each ECS12A must be assembled with n.4 tie rod kit.

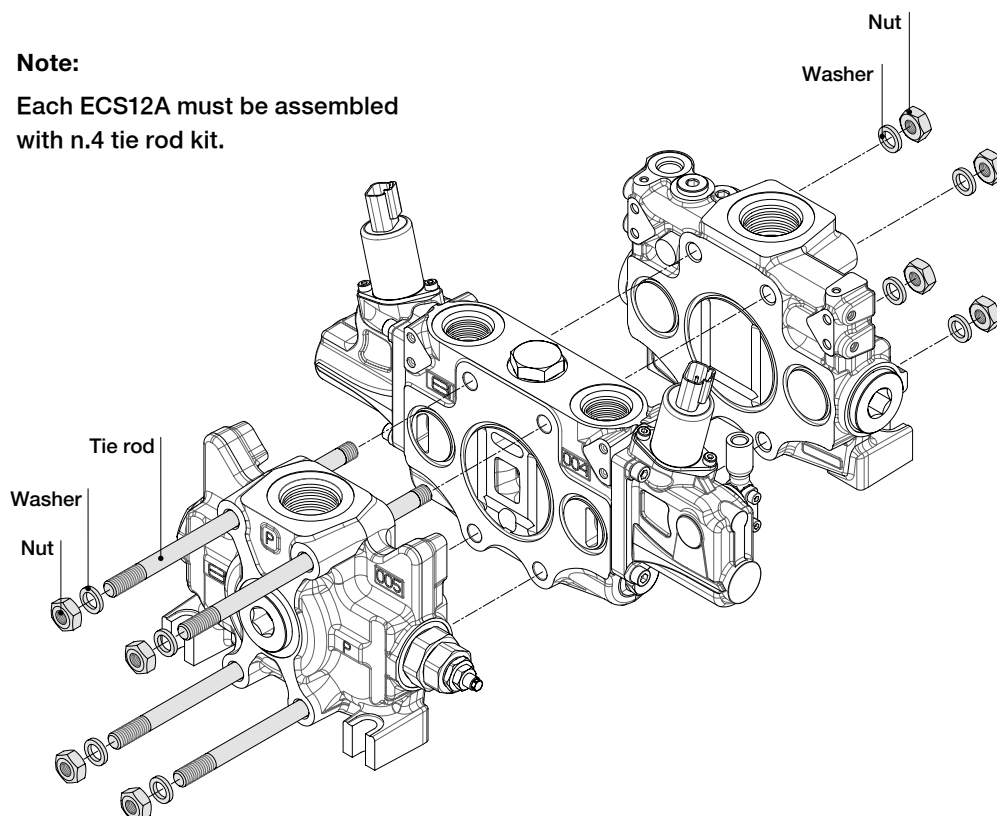

INLET SECTION

2	3			4					5				
L	P	1	4	S	V	0	1	1	5	0	V	0	2

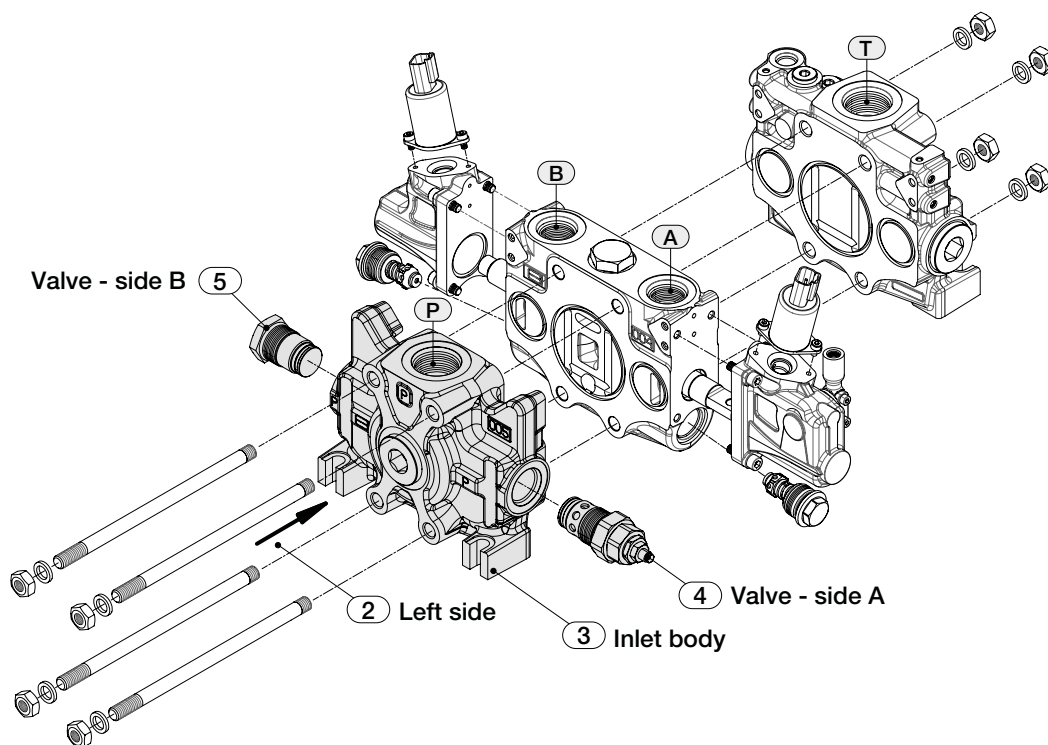

This example represents inlet section ECS12A with left configuration.

- L**.....left inlet side
- P14S**.....Upper inlet - 1”1/16-12 UNF (SAE12)
- V01150**.....Pilot operated pressure relief valve (150 bar) - side A
- V02**.....Relief valve plugged - side B

INLET SIDE

On all sectional ECS12A valves it is possible to choose a RIGHT or LEFT inlet.

CODE	DESCRIPTION	DRAWING	CODE	DESCRIPTION	DRAWING
L	Inlet side LEFT		R	Inlet side RIGHT	

Convention for all ECS12A valves with inlet right (R) or left inlet (L):

- side A = spool actuation side
- side B = spool return action side.

INLET SECTION

2	3	4	5
L	P 1 4 S	V 0 1 1 5 0	V 0 2

ARRANGEMENT INLET BODY

ECS12A arrangement body inlet is available in two configurations: SAE thread or BSP thread. The maximum flexibility of the inlet body configuration is guaranteed by the positioning of the service ports plug. This table represents arrangement inlet body in left configuration.

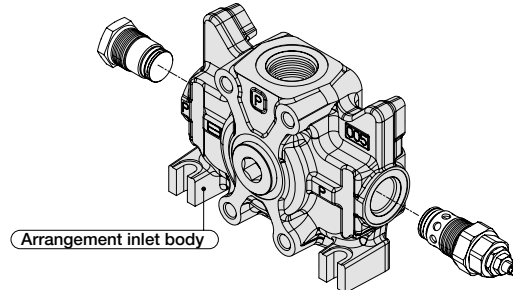

CODE	DESCRIPTION	CONFIGURATION
P14S	Upper inlet - 1"1/16-12 UNF (SAE12)	
P14B	Upper inlet - G 3/4	
P24S	Central inlet - 1"1/16-12 UNF (SAE12)	
P24B	Central inlet - G 3/4	
P34S	Upper inlet - 1"1/16-12 UNF (SAE12) with (P1) gauge connection SAE 6	
P34B	Upper inlet - G 3/4 with (P1) gauge connection G 1/4	
P44S	Central inlet - 1"1/16-12 UNF (SAE12) with (P1) gauge connection SAE 6	
P44B	Central inlet - G 3/4 with (P1) gauge connection G 1/4	



Note:

Inlet section with 1"5/16-12 UNF (SAE16) thread or G 1" thread are available on request.

INLET SECTION

2	3				4					5			
L	P	1	4	S	V	0	1	1	5	0	V	0	2

INLET VALVE CLASSIFICATION

All inlet sections require double choice on side A and side B; in the following table the available valves are shown.

- Valve type V01 and V03 requires factory setting (V01150-V03150); 150 is a value expressed in bar
- Valve type V04 includes coil kit
- 3 coil types are available in 12 and 24 Volt versions: DIN, DEUTSCH DT04 and AMP JUNIOR

CODE	DESCRIPTION	SYMBOL
V01	Pilot operated pressure relief valve	
V02	Relief valve plugged	
V03	Direct pressure relief valve	
V0412A	Solenoid dump valve 12 VDC - AMP Junior	 All solenoid dump valves are fitted with push and twist override
V0424A	Solenoid dump valve 24 VDC - AMP Junior	
V0412D	Solenoid dump valve 12 VDC - DT04 Deutsch	
V0424D	Solenoid dump valve 24 VDC - DT04 Deutsch	
V0412H	Solenoid dump valve 12 VDC - DIN 43650	
V0424H	Solenoid dump valve 24 VDC - DIN 43650	
V06	Main anticavitation check valve	

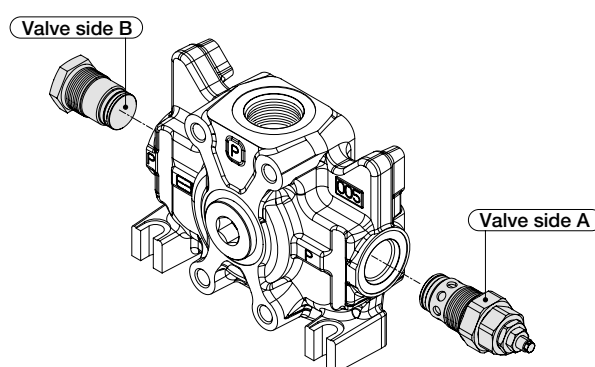

The example represents inlet section in left configuration; valve V01150 type on side A and valve V02 type on side B

- Valve side A = spool actuation side
- Valve side B = spool return action side

SETTING RANGE

Pilot operated pressure relief valve (V01): 50/350 bar
 Direct pressure relief valve (V03): 50/350 bar

In the following table the available valve combinations are shown.

valve combination	VALVE PORT B									
	V01	V02	V03	V0412A	V0424A	V0412D	V0424D	V0412H	V0424H	V06
VALVE PORT A	V01	•		•	•	•	•	•	•	•
	V02	•	•	•	•	•	•	•	•	•
	V03		•	•	•	•	•	•	•	•
	V0412A	•	•							•
	V0424A	•	•							•
	V0412D	•	•							•
	V0424D	•	•							•
	V0412H	•	•							•
	V0424H	•	•							•
	V06	•	•		•	•	•	•	•	•



INLET SECTION

PERFORMANCE DATA - PILOT OPERATED PRESSURE RELIEF VALVE (V01)

Pressure characteristic as function of flow

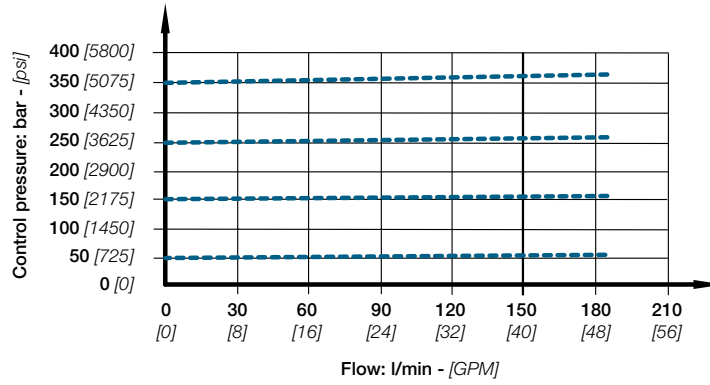

PERFORMANCE DATA - DIRECT PRESSURE RELIEF VALVE (V03)

Pressure characteristic as function of flow

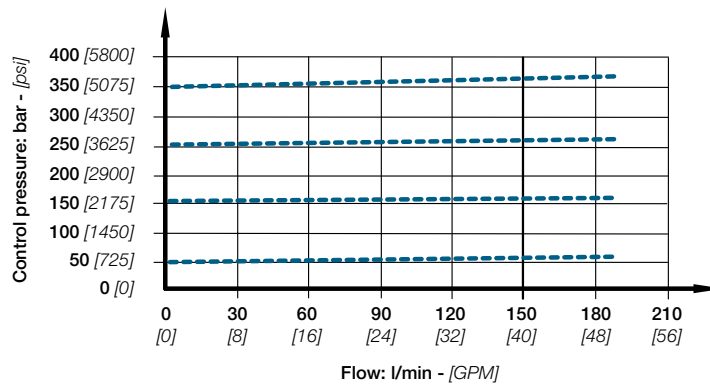

PERFORMANCE DATA - MAIN ANTICAVITATION CHECK VALVE (V06)

Pressure characteristic as function of flow

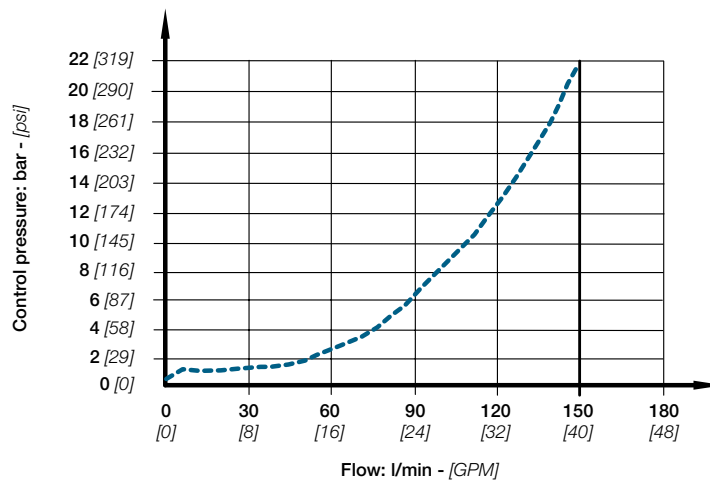

WORK SECTION

6	7				8				9			10			11			12			13														
L	S	1	P	2	E	4	S	V	5	1	1	0	0	V	5	1	1	8	0	S	0	1	N	A	E	0	1	R	E	0	1	K	1	2	D

This code indicates the complete working section set up; arrangement body, auxiliary valves, spool, actuation type and return action type.

- Should you order the working section only, you must specify the entry side: right (R) or left (L)
- Leave out the spool return action code when choosing hydraulic actuation "AH"
- Sections designed to house auxiliary valve option require double choice on work ports A and B
- Connector kit must be ordered separately with all electrohydraulic actuations; 2 coil kit each work section.

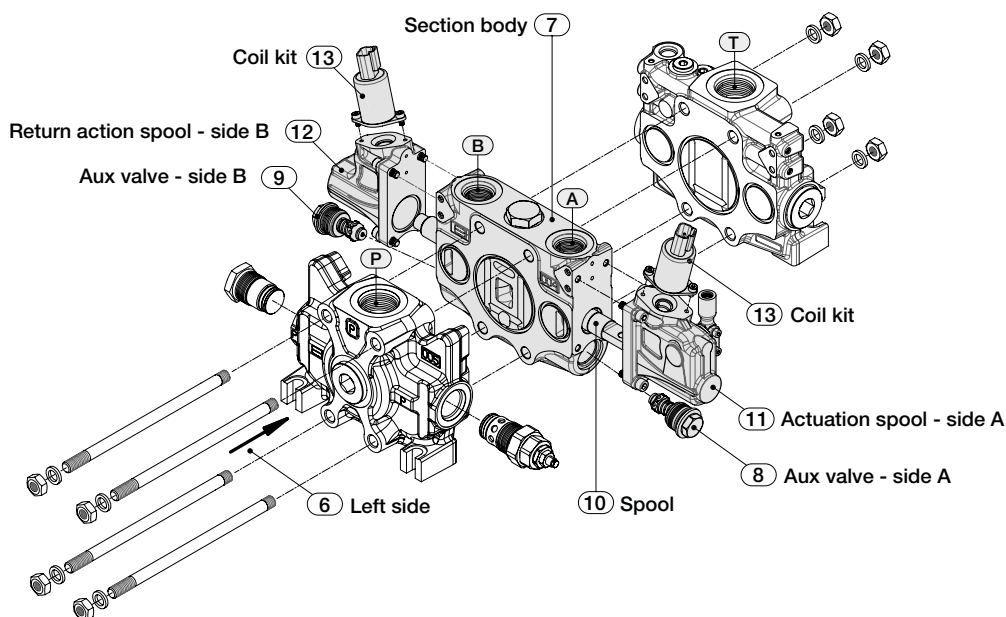

This example represents work section ECS12A with left configuration:

- L**Left side
- S1P2E4S**Parallel section with fixed valves - ports 1"1/16-12 UNF (SAE12)
- V51100**Fixed setting combined valve (100 bar) - port A
- V51180**Fixed setting combined valve (180 bar) - port B
- S01N**Spool 3 positions double-acting (150 l/min)
- AE01**Electrohydraulic actuation with lever control - side A
- RE01**Electrohydraulic control return action - side B
- K12D**Connector coil kit - 12 VDC Deutsch DT04

CODE	DESCRIPTION	DRAWING	CODE	DESCRIPTION	DRAWING
L	Inlet side LEFT		R	Inlet side RIGHT	

Convention for all ECS12A valves with inlet right (R) or left inlet (L):

- side A = spool actuation side
- side B = spool return action side.

WORK SECTION

6	7	8	9	10	11	12	13
L	S 1 P 2 E 4 S	V 5 1 1 0 0	V 5 1 1 8 0	S 0 1 N	A E 0 1	R E 0 1	K 1 2 D

ARRANGEMENT SECTION BODY

ECS12A arrangement section is available in two configurations: SAE thread or BSP thread.

Work section is available with parallel circuit or tandem circuit.

There are two types of arrangement section body:

- Body for electrohydraulic actuation
- Body for mechanical or hydraulic actuation.

Each arrangement section contains:

- Body
- Check valve
- Gasket kit.

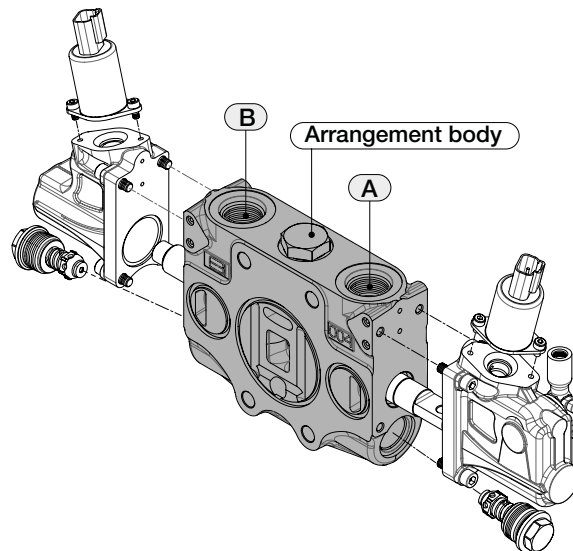

The Gasket kit allows the correct coupling between the surfaces of the working sections. The gasket kit changes according to the type of the working section; the number and type of gaskets is different between a mechanically operated section and a section with an electrohydraulic control (see the following table).

GASKET KIT FOR ELECTROHYDRAULIC SECTION

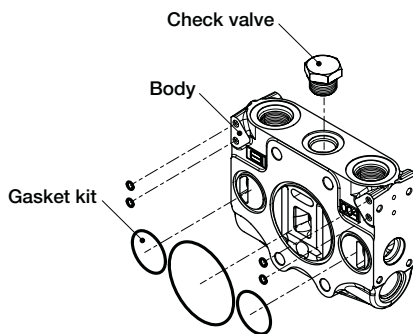

GASKET KIT FOR MECHANICAL OR HYDRAULIC SECTION

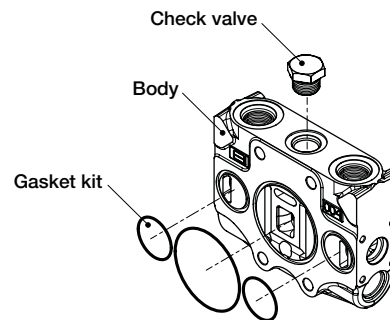

Each work section can be ordered with or without auxiliary valves; in the following table the two different sections are shown.

ARRANGEMENT SECTION BODY WITH AUXILIARY VALVES

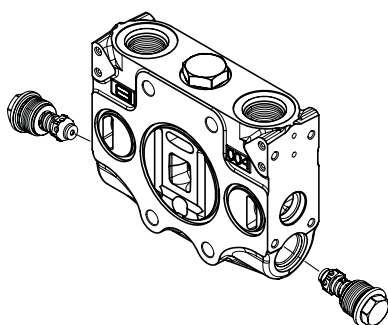

ARRANGEMENT SECTION BODY WITHOUT AUXILIARY VALVES

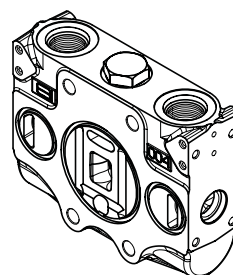

WORK SECTION

ARRANGEMENT BODY FOR MECHANICAL OR HYDRAULIC ACTUATION (PARALLEL CIRCUIT)

CODE	DESCRIPTION	CONFIGURATION
S1P1M4S	PARALLEL section with adjustable valves ports 1"1/16-12 UNF (SAE12) <i>(only for valve type: V55 - V57)</i>	
S1P1M4B	PARALLEL section with adjustable valves ports G 3/4 <i>(only for valve type: V55 - V57)</i>	
S1P2M4S	PARALLEL section with fixed valves ports 1"1/16-12 UNF (SAE12) <i>(only for valve type: V51 - V52 - V53 - V59)</i>	
S1P2M4B	PARALLEL section with fixed valves ports G 3/4 <i>(only for valve type: V51 - V52 - V53 - V59)</i>	
S2P1M4S	PARALLEL section without valves ports 1"1/16-12 UNF (SAE12)	
S2P1M4B	PARALLEL section without valves ports G 3/4	

ARRANGEMENT BODY FOR MECHANICAL OR HYDRAULIC ACTUATION (TANDEM CIRCUIT)

CODE	DESCRIPTION	CONFIGURATION
S1T1M4S	TANDEM section with adjustable valves ports 1"1/16-12 UNF (SAE12) <i>(only for valve type: V55 - V57)</i>	
S1T1M4B	TANDEM section with adjustable valves ports G 3/4 <i>(only for valve type: V55 - V57)</i>	
S1T2M4S	TANDEM section with fixed valves ports 1"1/16-12 UNF (SAE12) <i>(only for valve type: V51 - V52 - V53 - V59)</i>	
S1T2M4B	TANDEM section with fixed valves ports G 3/4 <i>(only for valve type: V51 - V52 - V53 - V59)</i>	
S2T1M4S	TANDEM section without valves ports 1"1/16-12 UNF (SAE12)	
S2T1M4B	TANDEM section without valves ports G 3/4	

WORK SECTION

ARRANGEMENT BODY FOR ELECTROHYDRAULIC ACTUATION (PARALLEL CIRCUIT)

CODE	DESCRIPTION	CONFIGURATION
S1P1E4S	PARALLEL section with adjustable valves ports 1"1/16-12 UNF (SAE12) <i>(only for valve type: V55 - V57)</i>	
S1P1E4B	PARALLEL section with adjustable valves ports G 3/4 <i>(only for valve type: V55 - V57)</i>	
S1P2E4S	PARALLEL section with fixed valves ports 1"1/16-12 UNF (SAE12) <i>(only for valve type: V51 - V52 - V53 - V59)</i>	
S1P2E4B	PARALLEL section with fixed valves ports G 3/4 <i>(only for valve type: V51 - V52 - V53 - V59)</i>	
S2P1E4S	PARALLEL section without valves ports 1"1/16-12 UNF (SAE12)	
S2P1E4B	PARALLEL section without valves ports G 3/4	

ARRANGEMENT BODY FOR ELECTROHYDRAULIC ACTUATION (TANDEM CIRCUIT)

Note:

For Tandem sections with electrohydraulic actuation, please contact our Sales Office.

WORK SECTION

ARRANGEMENT BODY FOR MECHANICAL OR HYDRAULIC ACTUATION (PARALLEL CIRCUIT) - ONLY FOR SECTION WITH S05 SPOOL TYPE -

CODE	DESCRIPTION
SF1P1M4S	PARALLEL section with adjustable valves - ports 1"1/16-12 UNF (SAE12) <i>(only for valve type: V55 - V57)</i>
SF1P1M4B	PARALLEL section with adjustable valves - ports G 3/4 <i>(only for valve type: V55 - V57)</i>
SF1P2M4S	PARALLEL section with fixed valves - ports 1"1/16-12 UNF (SAE12) <i>(only for valve type: V51 - V52 - V53 - V59)</i>
SF1P2M4B	PARALLEL section with fixed valves - ports G 3/4 <i>(only for valve type: V51 - V52 - V53 - V59)</i>

ARRANGEMENT BODY FOR ELECTROHYDRAULIC ACTUATION (PARALLEL CIRCUIT) - ONLY FOR SECTION WITH S05 SPOOL TYPE -

CODE	DESCRIPTION
SF1P1E4S	PARALLEL section with adjustable valves - ports 1"1/16-12 UNF (SAE12) <i>(only for valve type: V55 - V57)</i>
SF1P1E4B	PARALLEL section with adjustable valves - ports G 3/4 <i>(only for valve type: V55 - V57)</i>
SF1P2E4S	PARALLEL section with fixed valves - ports 1"1/16-12 UNF (SAE12) <i>(only for valve type: V51 - V52 - V53 - V59)</i>
SF1P2E4B	PARALLEL section with fixed valves - ports G 3/4 <i>(only for valve type: V51 - V52 - V53 - V59)</i>

WORK SECTION

6	7	8	9	10	11	12	13
L	S 1 P 2 E 4 S	V 5 1 1 0 0	V 5 1 1 8 0	S 0 1 N	A E 0 1	R E 0 1	K 1 2 D

AUXILIARY VALVES

ECS12A sections with auxiliary valves require double choice on work side A and side B.

The bodies with a fixed setting valve housing are different from bodies with adjustable valves housing.

CODE	DESCRIPTION	SYMBOL	SETTING
V51	Fixed setting combined valve		50 - 350 bar
V52	Fixed setting valve plugged		
V53	Fixed setting anticavitation valve		
V55	Adjustable valve plugged		
V57	Adjustable pilot combined valve		50 - 350 bar
V59	Fixed setting Adjustable combined valve <i>(fit into fixed valve cavity)</i>		50 - 350 bar

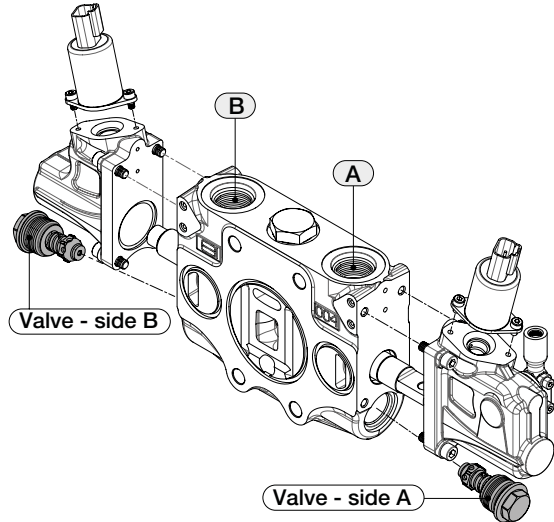

Valves type V51, V57 and V59 require factory setting:

V51100: 100 = value expressed in bar

factory setting is available from 50 to 350 bar with 10 bar steps.

V57100: 100 = value expressed in bar

factory setting is available from 50 to 350 bar with 5 bar steps.

V59100: 100 = value expressed in bar

factory setting is available from 50 to 350 bar with 10 bar steps.

Fixed setting valve (V59) AVAILABLE RANGE

Range (A) = 20 - 90 bar

Range (B) = 91 - 170 bar

Range (C) = 171 - 250 bar

Range (D) = 251 - 330 bar

Range (E) = 331 - 410 bar

Fixed setting combined valve (V51)
Pressure characteristic as function of flow

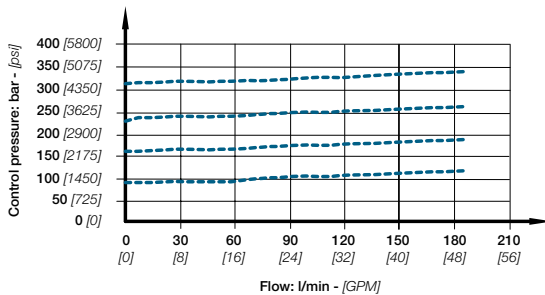

Adjustable Pilot combined valve (V57)
Pressure characteristic as function of flow

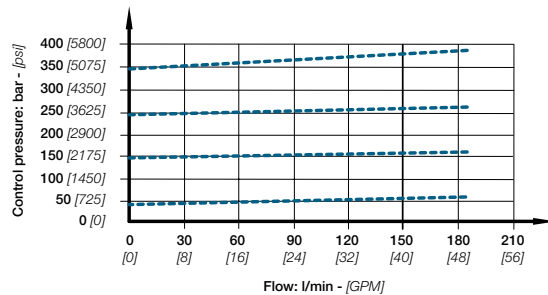

Fixed setting anticavitation valve (V53)
Pressure characteristic as function of flow

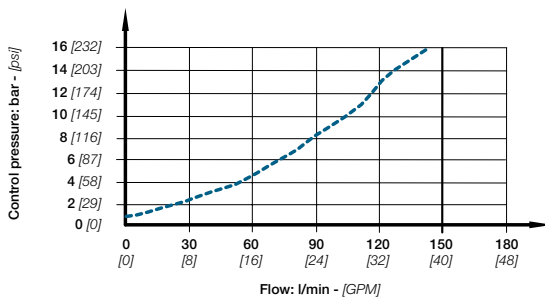

Fixed setting Adjustable combined valve (V59)
Pressure characteristic as function of flow

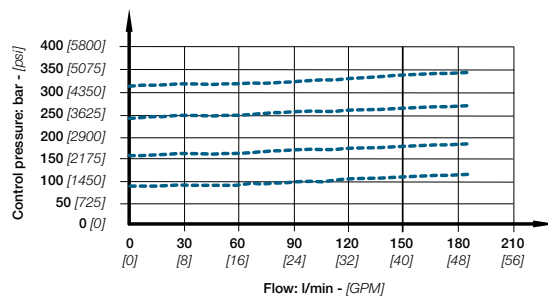

WORK SECTION

6	7	8	9	10	11	12	13
L	S 1 P 2 E 4 S	V 5 1 1 0 0	V 5 1 1 8 0	S 0 1 N	A E 0 1	R E 0 1	K 1 2 D

SPOOL CLASSIFICATION

Each ECS12A section contains a spool; each spool is compatible with all actuations.

Example with spool 3 position double acting:

S01N Nominal flow (150 l/min)

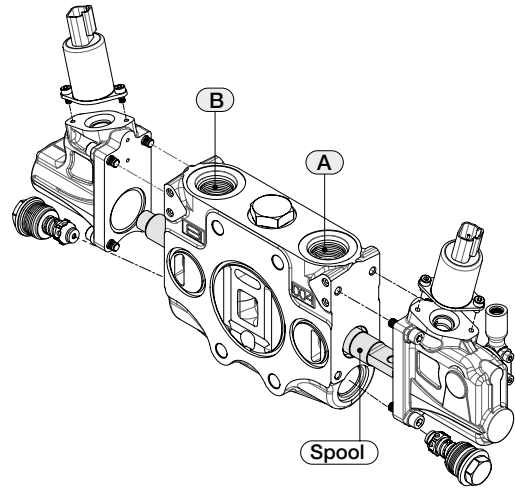

CODE	DESCRIPTION	SYMBOL
S01N	Spool 3 positions double acting	
S02N	Spool 3 positions double acting A/B to tank	
S03N	Spool 3 positions single acting on A	
S04N	Spool 3 positions single acting on B	
S05N	Spool 4 positions double acting with float in 4th position	
S11N	Spool 3 positions double acting A to tank - B blocked	
S12N	Spool 3 positions double acting A blocked - B to tank	



Note:

S05 spool needs a special machining on the body and a special detent kit. The spools shown correspond to standard configuration, for different applications, please contact our Sales Office.

WORK SECTION

6	7	8	9	10	11	12	13
L	S 1 P 2 E 4 S	V 5 1 1 0 0	V 5 1 1 8 0	S 0 1 N	A E 0 1	R E 0 1	K 1 2 D

SPOOL ACTUATION

Spool actuations are classified in three categories:

MECHANICAL ACTUATION

- Requires the choice of spool return action (side B).
- Requires a dedicated body.

HYDRAULIC ACTUATION

- Leave out the spool return action code when choosing hydraulic actuation AH01B, AH01S, AH02B, AH02S, AH04B and AH04S.
- Requires a dedicated body.

ELECTROHYDRAULIC ACTUATION

- Requires a dedicated body.

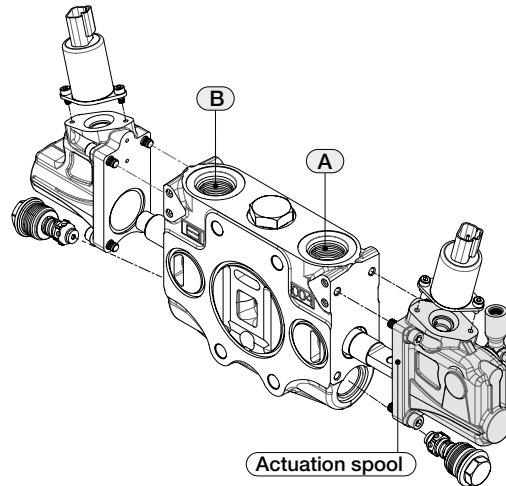

SPOOL ACTUATION - SIDE A (MECHANICAL ACTUATION)

CODE	DESCRIPTION	CONFIGURATION	SYMBOL
AM01	Control lever		
AM02	Control lever rotated 180°		
AM05	Control tang spool end Spool end thickness = 8 MM Spool end hole = Ø8 MM		
AM20	Control lever FLOAT - only with spool S05 - only with a special body		

WORK SECTION

JOYSTICK CONTROL ACTUATION

The Joystick option is made to control 2 spools at the same time with one hand. The way it can manage the flow is based on the fulcrum position so the code.

In the following table you can refer lever actuation against flow on valve ports (A/B).

Actuation code for spool without fulcrum is always **AJ00**

Note: Lever for joystick control (M12) has to be ordered separately.

CODE	DESCRIPTION	FULCRUM POSITIONS	DRAWING	ACTUATIONS
AJ1L	Joystick control LEFT SIDE INLET Fulcrum on 1 st section	First section Second section AJ00		
AJ2L	Joystick control LEFT SIDE INLET Fulcrum on 2 nd section	Second section First section AJ00		
AJ1R	Joystick control RIGHT SIDE INLET Fulcrum on 1 st section	First section Second section AJ00		
AJ2R	Joystick control RIGHT SIDE INLET Fulcrum on 2 nd section	Second section First section AJ00		

WORK SECTION

SPOOL ACTUATION (HYDRAULIC ACTUATION)



CODE	DESCRIPTION	CONFIGURATION	SYMBOL
AH01B	Hydraulic actuation with side ports (G 1/4)		
AH01S	Hydraulic actuation with side ports (SAE 6)		
AH02B	Hydraulic actuation with upper ports (G 1/4)		
AH02S	Hydraulic actuation with upper ports (SAE 6)		
AH04B	Hydraulic actuation with stroke limiter ports (G 1/4)		
AH04S	Hydraulic actuation with stroke limiter ports (SAE 6)		

SPRING CHARACTERISTIC CURVES HYDRAULIC ACTUATION

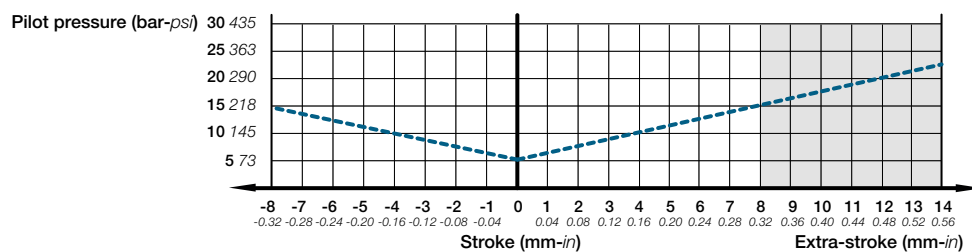
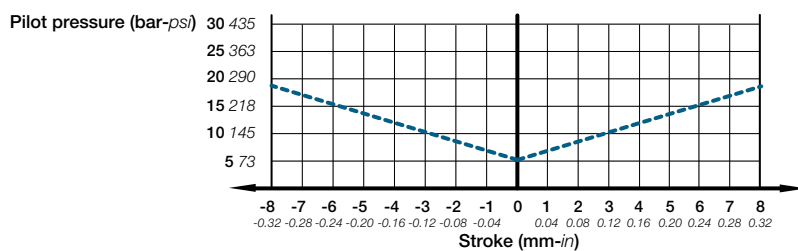
The graph shows the spool stroke as a function of the pressure operating.

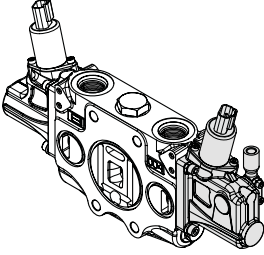
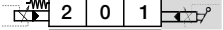
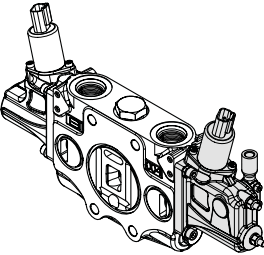

WORK SECTION
SPOOL ACTUATION - SIDE A (ELECTROHYDRAULIC ACTUATION)

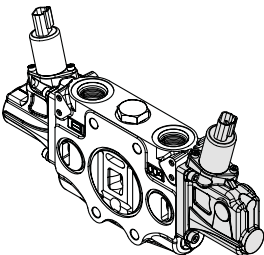
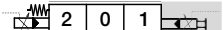
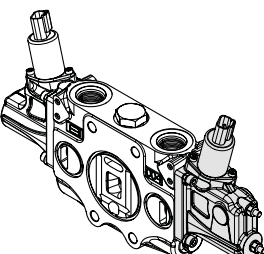
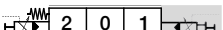
CODE	DESCRIPTION	CONFIGURATION	SYMBOL
AE01	Electrohydraulic actuation with lever control		
AE02	Electrohydraulic actuation with lever control and stroke limiter		
AE03	Electrohydraulic actuation without lever control		
AE04	Electrohydraulic actuation without lever control and stroke limiter		

Note:

To work properly, EH actuations need a minimum pressure value of 9 bar on pressure inlet port P. Please be sure to have this pressure level before to operate EH valves.

WORK SECTION

6	7				8				9			10			11			12			13														
L	S	1	P	2	E	4	S	V	5	1	1	0	0	V	5	1	1	8	0	S	0	1	N	A	E	0	1	R	E	0	1	K	1	2	D

SPOOL RETURN ACTION

ECS12A spool return action are classified in two categories:

- Mechanical return action spool
- Electrohydraulic return action spool

Spool return action for mechanical actuation have three different spring types:

- **M** (medium spring)
- **S** (soft spring)
- **H** (heavy spring)

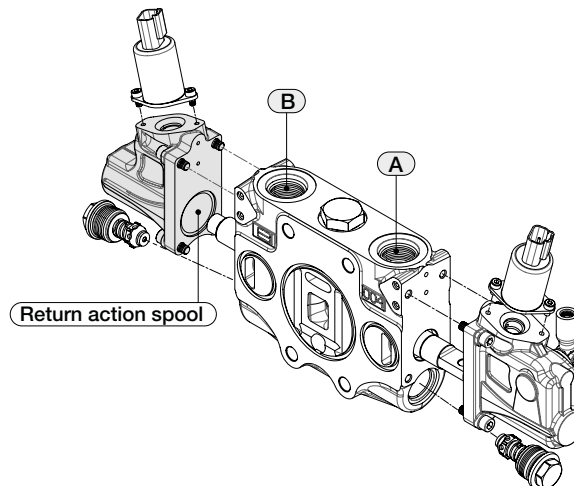

SPRING	F1 PRELOADING (N)	F2 END STROKE (N)
M (medium)	128	178
S (soft)	105	145
H (heavy)	180	250

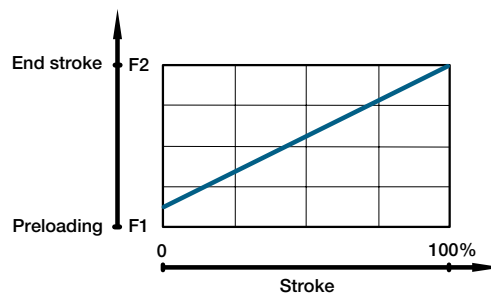

SPOOL RETURN ACTION - SIDE B (MECHANICAL ACTUATION)

CODE	DESCRIPTION	CONFIGURATION	SYMBOL
RM01M	3 position spring centered spool (MEDIUM spring)		
RM01S	3 position spring centered spool (SOFT spring)		
RM01H	3 position spring centered spool (HEAVY spring)		
RM04M	Detent in position 1/2		
RM05M	Detent in position 1		
RM06M	Detent in position 2		
RM11M	Detent in 4th position		
RM12	Detent in position 1/0/2 without spring		

WORK SECTION

CODE	DESCRIPTION	CONFIGURATION	SYMBOL
RR01	Proportional pneumatic control (connections G 1/8)		
RR03	Proportional pneumatic control (connections NPTF 1/8-27)		

SPRING CHARACTERISTIC CURVE PNEUMATIC CONTROL

The diagram shows the spool stroke as a function of the pneumatic pressure operating.

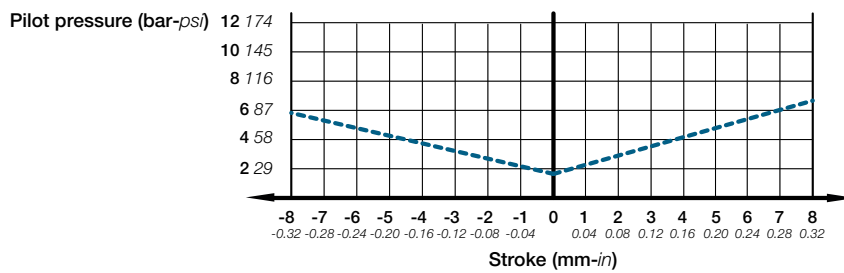

SPOOL RETURN ACTION - SIDE B (ELECTROHYDRAULIC ACTUATION)

CODE	DESCRIPTION	CONFIGURATION	SYMBOL
RE01	Spool return kit for Electrohydraulic actuation <i>(only for: AE01-AE02-AE03)</i>		

SPRING CHARACTERISTIC CURVES EH ACTUATION

The graph shows the spool stroke as a function of the pressure operating.

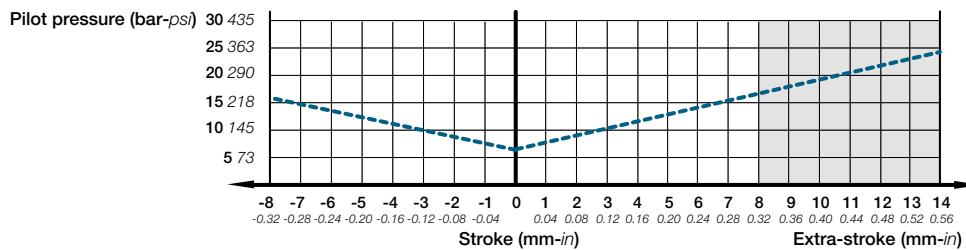

Note:

The Assembly Spool Return Microswitch is available on request. For more informations, please contact our Sales Office.

RP01 Assembly Spool Return Microswitch

WORK SECTION

6	7				8				9				10			11			12			13													
L	S	1	P	2	E	4	S	V	5	1	1	0	0	V	5	1	1	8	0	S	0	1	N	A	E	0	1	R	E	0	1	K	1	2	D

COIL KIT

Coil kit must be ordered separately with all electrohydraulic actuators.

2 coil types are available in 12 and 24 Volt versions:

- DEUTSCH DT04
- AMP JUNIOR

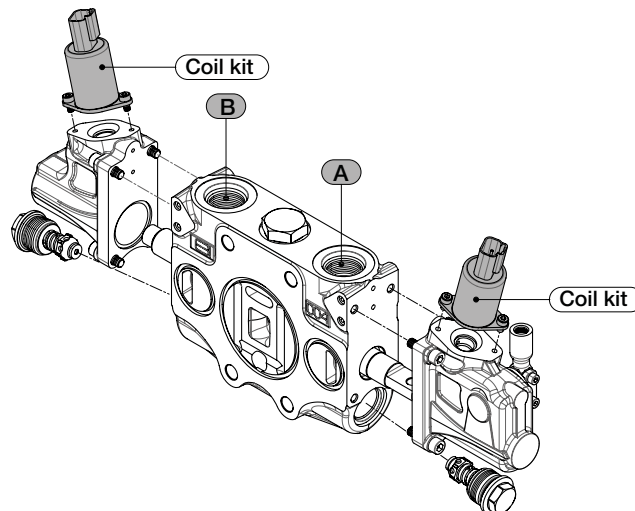

COIL AND CONNECTOR DATA

SPECIFICATIONS	K12D	K24D	K12A	K24A
Connector type	DEUTSCH DT04-2P		AMP Junior timer (AMP84-9419)	
Supply voltage	12 VDC	24 VDC	12 VDC	24 VDC
Coil resistance	4.7 Ohm ±5%	20.8 Ohm ±5%	4.7 Ohm ±5%	20.8 Ohm ±5%
Maximal current	1500±10 mA	750±10 mA	1500±10 mA	750±10 mA
PWM Frequency recommended	PWM 100 Hz			
Filter screen	125 µm			
Response time	< 50 ms			
Duty cycle	ED 100%			
Degree of protection	Deutsch IP69K		AMP IP65	
Connector color	Black		Mossy-grey	
Feeding reducing pressure	40 bar			
Max pressure on pilot tank line	5 bar			

CHARACTERISTIC CURVE CURRENT VS. PRESSURE (Less than 2% Hysteresis)

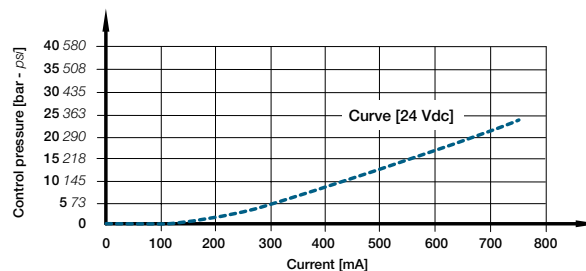
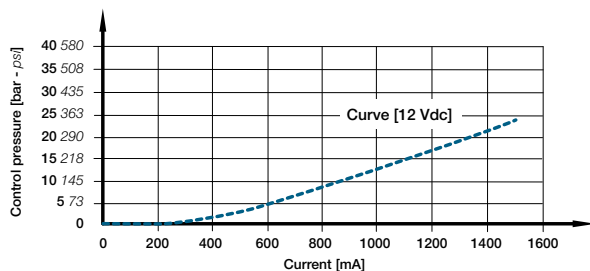

Note:
Mating connector for Deutsch DT04 is:
DT06-2S



OUTLET SECTION

14	15				
L	T	1	R	5	S

There are two main types of arrangement outlet section:

- **Outlet version with PRV**
to be used when at least one section in the directional valve has electrohydraulic actuation
- **Outlet version without PRV**
to be used when no electrohydraulic actuations are present in the directional valve

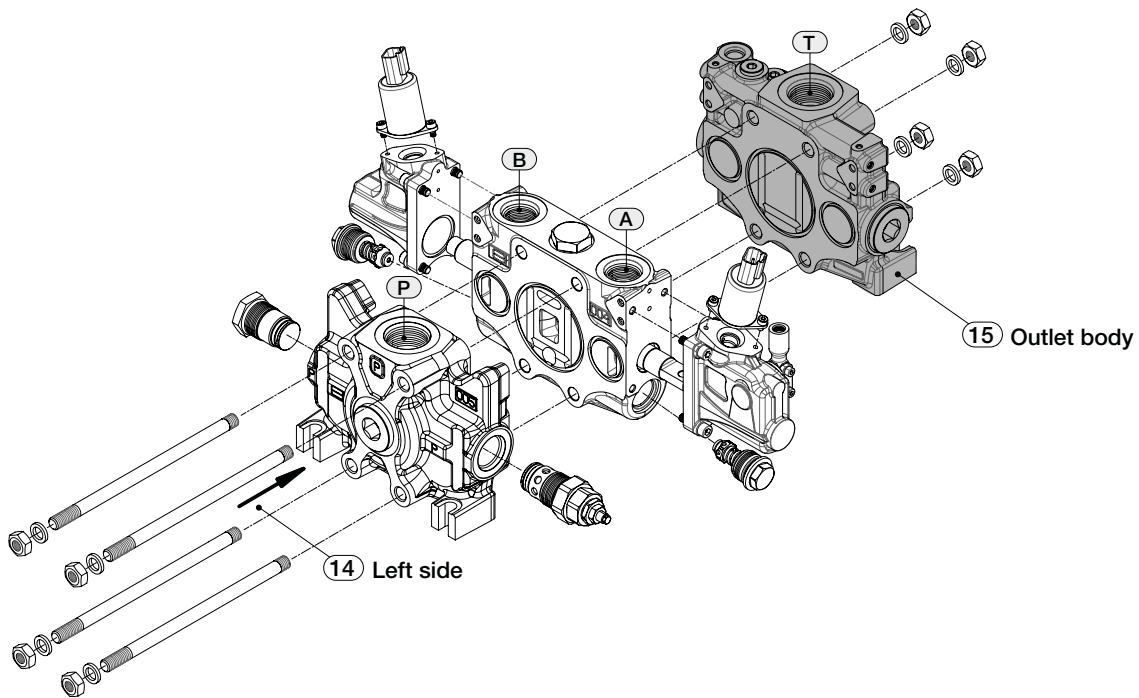

This example represents outlet section ECS12A with left configuration

- L**Left outlet side
- T1R5S**Upper outlet - 1"5/16-12 UNF (SAE16) with PRV

CODE	DESCRIPTION	DRAWING	DESCRIPTION	DRAWING
L	Outlet side LEFT		R	Outlet side RIGHT

Convention for all ECS12A valves with outlet right (R) or outlet left (L):

- side A = spool actuation side
- side B = spool return action side.

OUTLET SECTION

14	15				
L	T	1	R	5	S

ARRANGEMENT OUTLET BODY

ECS12A arrangement outlet body is available in two configurations: SAE thread or BSP thread. The maximum flexibility of the outlet body configuration is guaranteed by the positioning of the service ports plug.

It is possible to have simple T port or two ports configuration for HPCO connection; HPCO allows to extend the by-pass channel and connect a second directional valve.

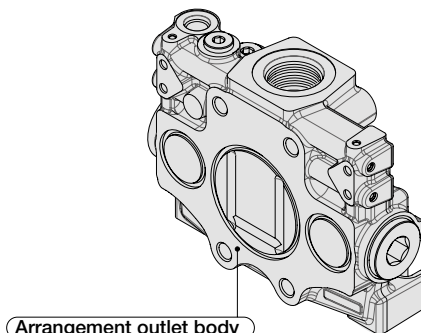

ALL OUTLET SECTION ECS12A CAN BE EASILY TRANSFORMED FROM SIMPLE T PORT TO HPCO CONFIGURATION JUST BY INSTALLING TWO CONIC PLUGS G3/8. [ORDER CODE: C03000001](#)

ARRANGEMENT OUTLET SECTION simple T port

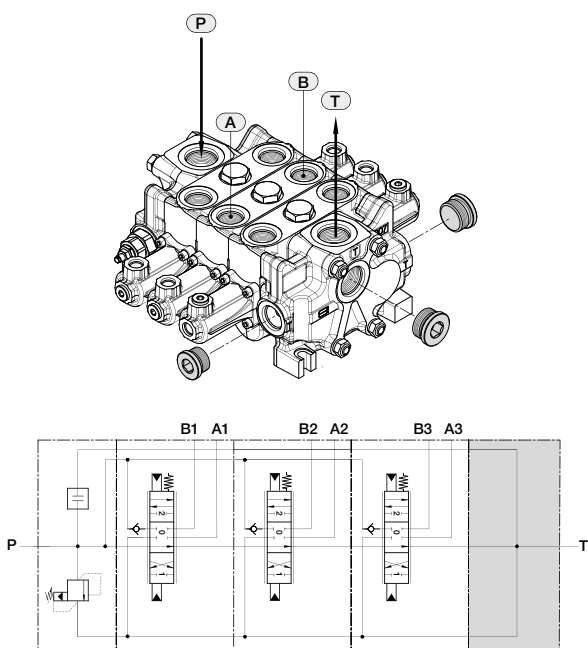

ARRANGEMENT OUTLET SECTION HPCO connection

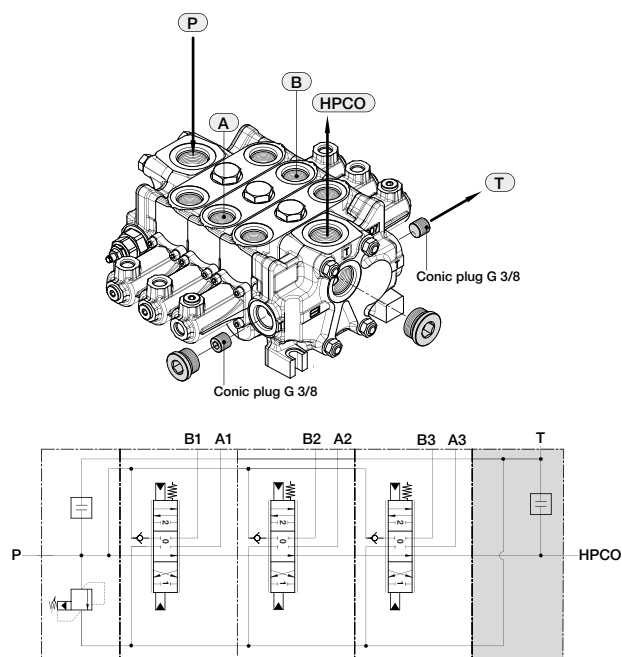

Note:

All outlet sections ECS12A for electrohydraulic configuration contain a pressure reducing valve (PRV).

We recommend to connect drain port T2 directly to tank, in order to avoid control system damages and inaccurate control.

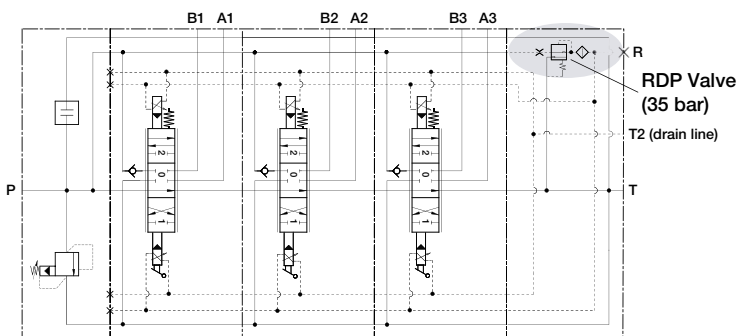

OUTLET SECTION

OUTLET CLASSIFICATION FOR MECHANICAL OR HYDRAULIC CONFIGURATION (SIMPLE T PORT)

CODE	DESCRIPTION	CONFIGURATION
T15S	Upper outlet - 1"5/16-12 UNF (SAE16)	
T15B	Upper outlet - G 1	
T25S	Central outlet - 1"5/16-12 UNF (SAE16)	
T25B	Central outlet - G 1	

OUTLET CLASSIFICATION FOR MECHANICAL OR HYDRAULIC CONFIGURATION (HPCO CONNECTION)

CODE	DESCRIPTION	CONFIGURATION
TH15S	HPCO Upper outlet - 1"5/16-12 UNF (SAE16) T side outlet B - 1"5/16-12 UNF (SAE16)	
TH15B	HPCO Upper outlet - G 1 T side outlet B - G 1	
TH25S	HPCO Central outlet - 1"5/16-12 UNF (SAE16) T side outlet B - 1"5/16-12 UNF (SAE16)	
TH25B	HPCO Central outlet - G 1 T side outlet B - G 1	

OUTLET SECTION

OUTLET CLASSIFICATION FOR ELECTROHYDRAULIC CONFIGURATION (SIMPLE T PORT)

CODE	DESCRIPTION	CONFIGURATION
T1R5S	Upper outlet - 1"5/16-12 UNF (SAE16) with PRV <i>T2 drain: 9/16-18 UNF thread</i>	
T1R5B	Upper outlet - G 1 with PRV <i>T2 drain: G 1/4" thread</i>	
T2R5S	Central outlet - 1"5/16-12 UNF (SAE16) with PRV <i>T2 drain: 9/16-18 UNF thread</i>	
T2R5B	Central outlet - G 1 with PRV <i>T2 drain: G 1/4" thread</i>	

OUTLET CLASSIFICATION FOR ELECTROHYDRAULIC CONFIGURATION (HPCO CONNECTION)

CODE	DESCRIPTION	CONFIGURATION
TH1R5S	HPCO Upper outlet - 1"5/16-12 UNF (SAE16) T side outlet B - 1"1/16-12 UNF (SAE12) with PRV <i>T2 drain: 9/16-18 UNF thread</i>	
TH1R5B	HPCO Upper outlet - G 1 T side outlet B - G 3/4 with PRV <i>T2 drain: G 1/4" thread</i>	
TH2R5S	HPCO Central outlet - 1"5/16-12 UNF (SAE16) T side outlet B - 1"1/16-12 UNF (SAE12) with PRV <i>T2 drain: 9/16-18 UNF thread</i>	
TH2R5B	HPCO Central outlet - G 1 T side outlet B - G 3/4 with PRV <i>T2 drain: G 1/4" thread</i>	

OUTLET SECTION

OUTLET SECTION WITH ELECTROHYDRAULIC ACTUATION - INSTALLATION ASSEMBLY PRV

ORDER CODE	DESCRIPTION
A01020002	Complete assembly kit PRV

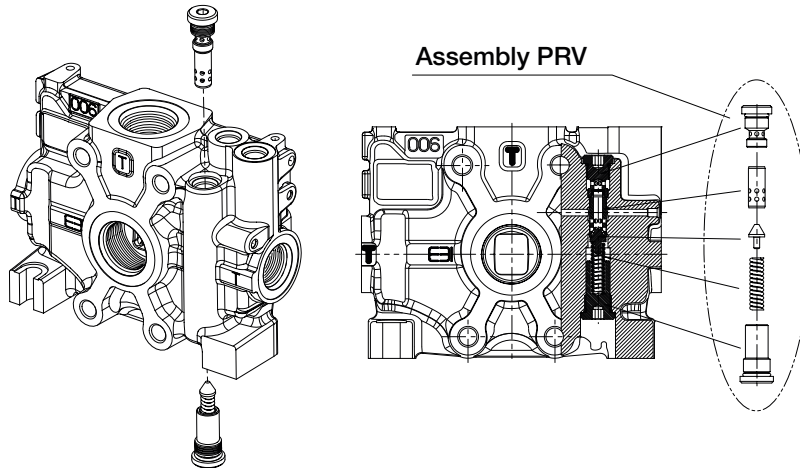

OUTLET CLASSIFICATION FOR ELECTROHYDRAULIC CONFIGURATION (SIMPLE T PORT) WITH PRV AND BUILD-UP PRESSURE.

CODE	DESCRIPTION	CONFIGURATION
T3RC4S	Outlet T side A front - 1"1/16-12 UNF (SAE12) with BUP <i>T2 drain: 9/16-18 UNF thread</i>	
T3RC4B	Outlet T side A front - G 1 with BUP <i>T2 drain: G 1/4" thread</i>	
T4RC4S	Outlet T side B rear - 1"1/16-12 UNF (SAE12) with BUP <i>T2 drain: 9/16-18 UNF thread</i>	
T4RC4B	Outlet T side B rear - G 1 with BUP <i>T2 drain: G 1/4" thread</i>	

Note:

HPCO Outlet can not cope with BUP (Build-up pressure) valve.

OUTLET SECTION

OUTLET SECTION WITH ELECTROHYDRAULIC ACTUATION - INSTALLATION BUILD-UP PRESSURE VALVE

For those systems where the pressure at P port is lower than 9 bar, EBI can offer a build-up pressure valve into the Outlet manifold able to increase the pressure at the P port inlet accordingly.

ORDER CODE	DESCRIPTION	NOTE
A01020007	Complete Build up pressure valve	for outlet with SAE ports
A01020013		for outlet with BSP ports

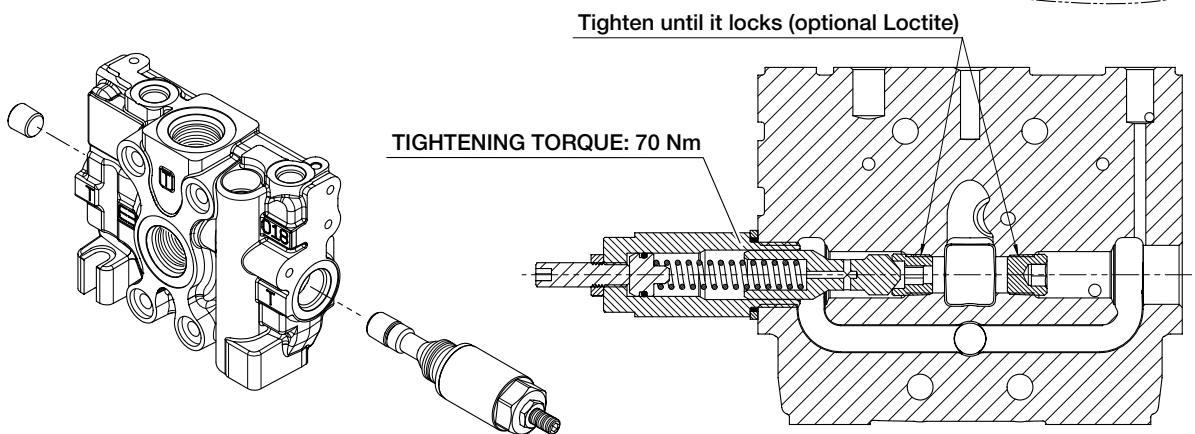
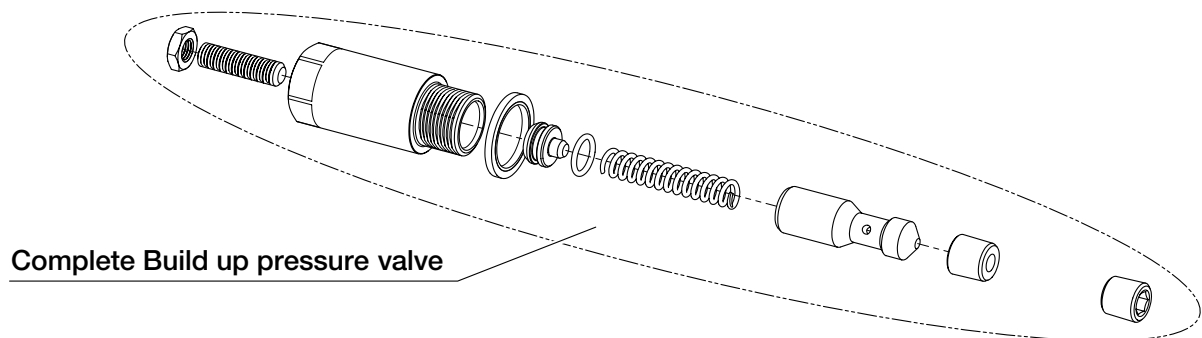



OPTION

PAINTING

On request all ECS12A directional control valves by EBI can be delivered painted (RAL 9005 black primer).

ORDER EXAMPLE OF ECS12A/1 PAINTED:

info	E	C	S	1	2	A	N	1																												
inlet	L	P	1	4	S	V	0	1	1	5	0	V	0	2																						
section	L	S	1	P	2	E	4	S	V	5	1	1	0	0	V	5	1	1	8	0	S	0	1	N	A	E	0	1	R	E	0	1	K	1	2	D
outlet	L	T	1	R	5	S																														
option	X	1																																		

X1 Painted color black

CODE	DESCRIPTION
X1	ECS12A with 1 work section painted
X2	ECS12A with 2 work sections painted
X3	ECS12A with 3 work sections painted
X4	ECS12A with 4 work sections painted
X5	ECS12A with 5 work sections painted
X6	ECS12A with 6 work sections painted
X7	ECS12A with 7 work sections painted
X8	ECS12A with 8 work sections painted
X9	ECS12A with 9 work sections painted
X10	ECS12A with 10 work sections painted
X11	ECS12A with 11 work sections painted
X12	ECS12A with 12 work sections painted

ACCESSORIES

LEVER ROD

The following table lists the levers available for the ECS12A control Valve.

CODE	DESCRIPTION	LENGHT	DRAWING	ORDER CODE
W10A	Lever rod for electrohydraulic actuation	145 mm		A01170013
W10B	Lever rod for mechanical actuation	195 mm		A01170014
W10C		245 mm		A01170009



Note:
The levers must be ordered separately.

GENERAL CLAMPING TORQUE

The following design provides the main tightening torques of the **INLET SECTION**

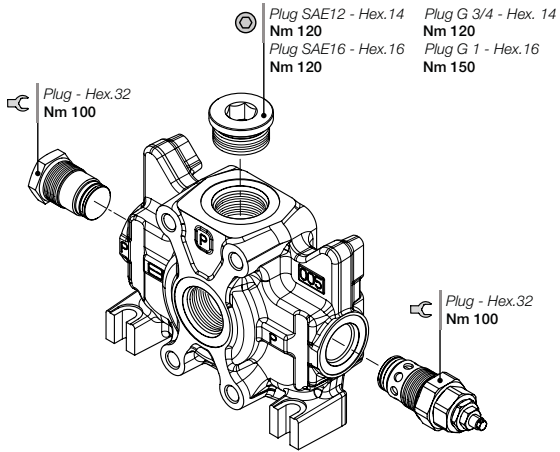

The following design provides the main tightening torques of the **OUTLET SECTION**

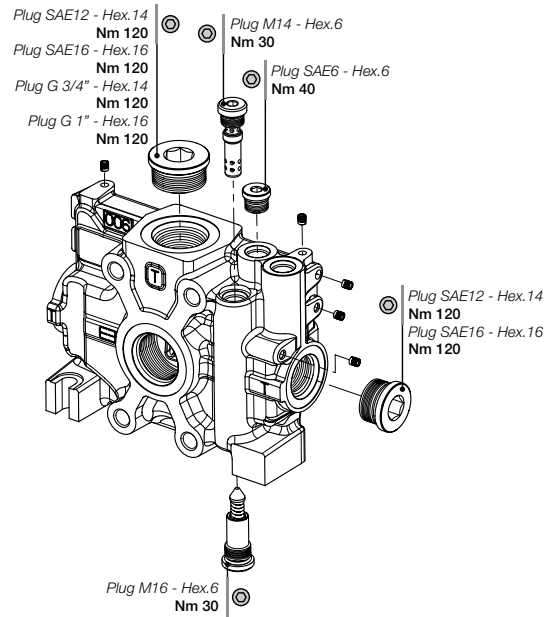

The following design provides the main tightening torques of the **WORK SECTION**

ELECTROHYDRAULIC ACTUATION

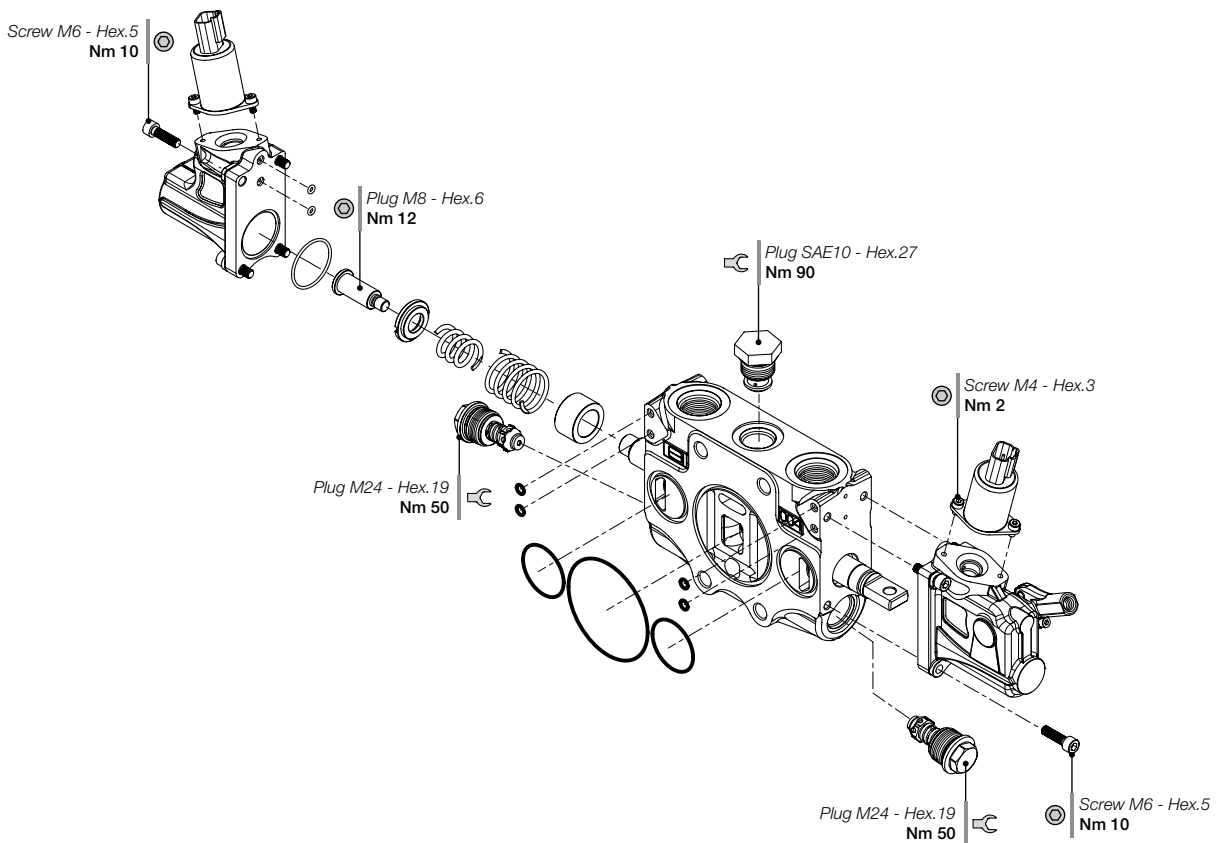

HYDRAULIC ACTUATION

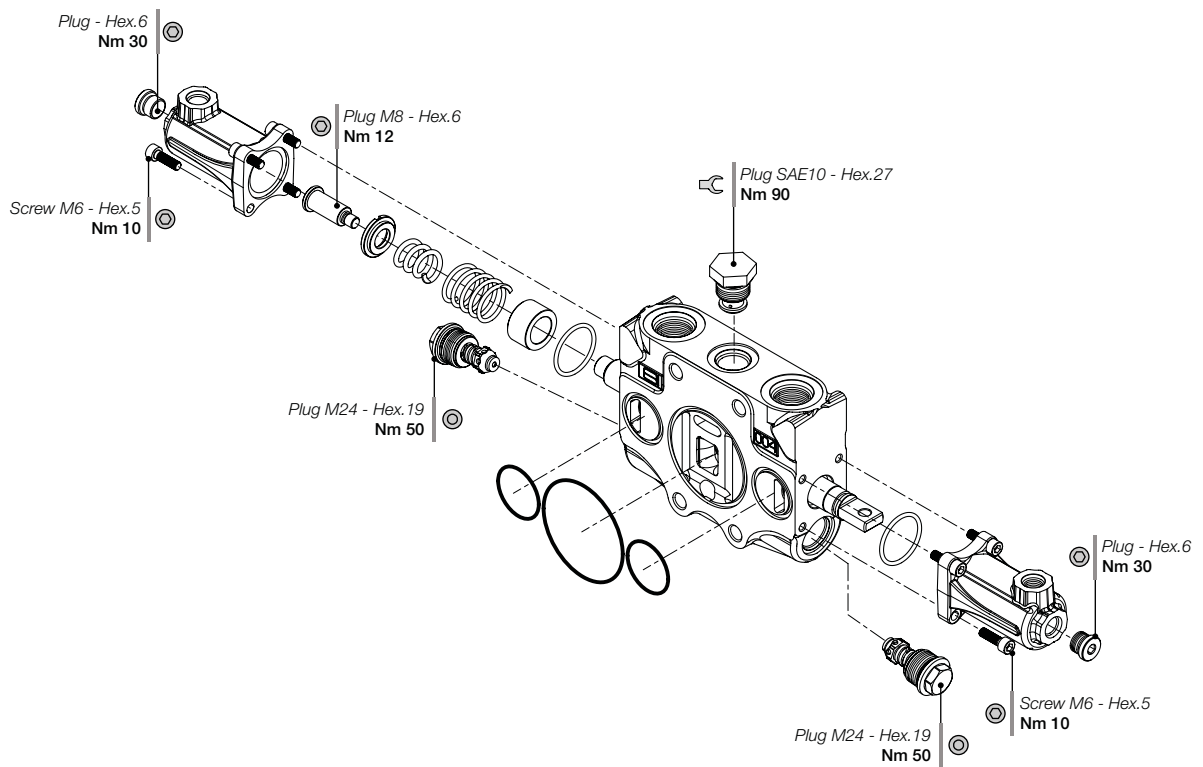

MECHANICAL ACTUATION - MANUAL, DETENT AND PNEUMATIC CONTROL

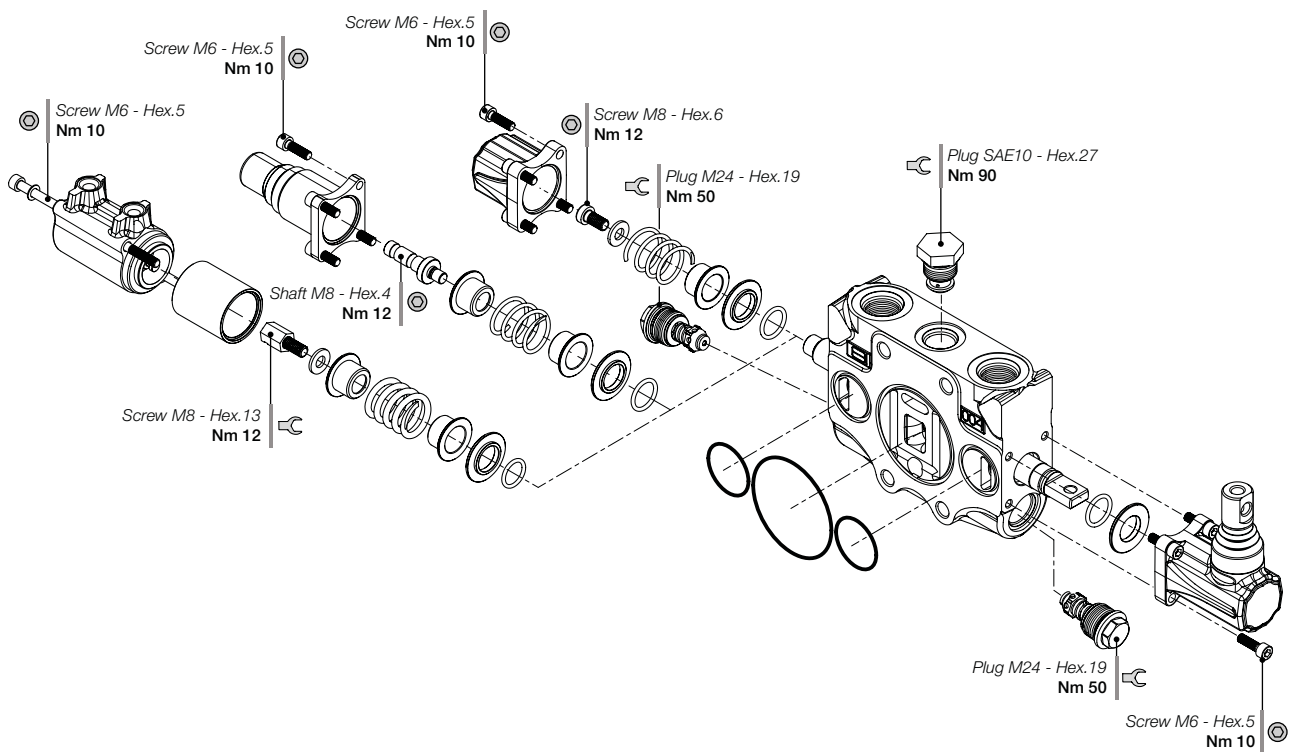

SPARE PARTS LIST

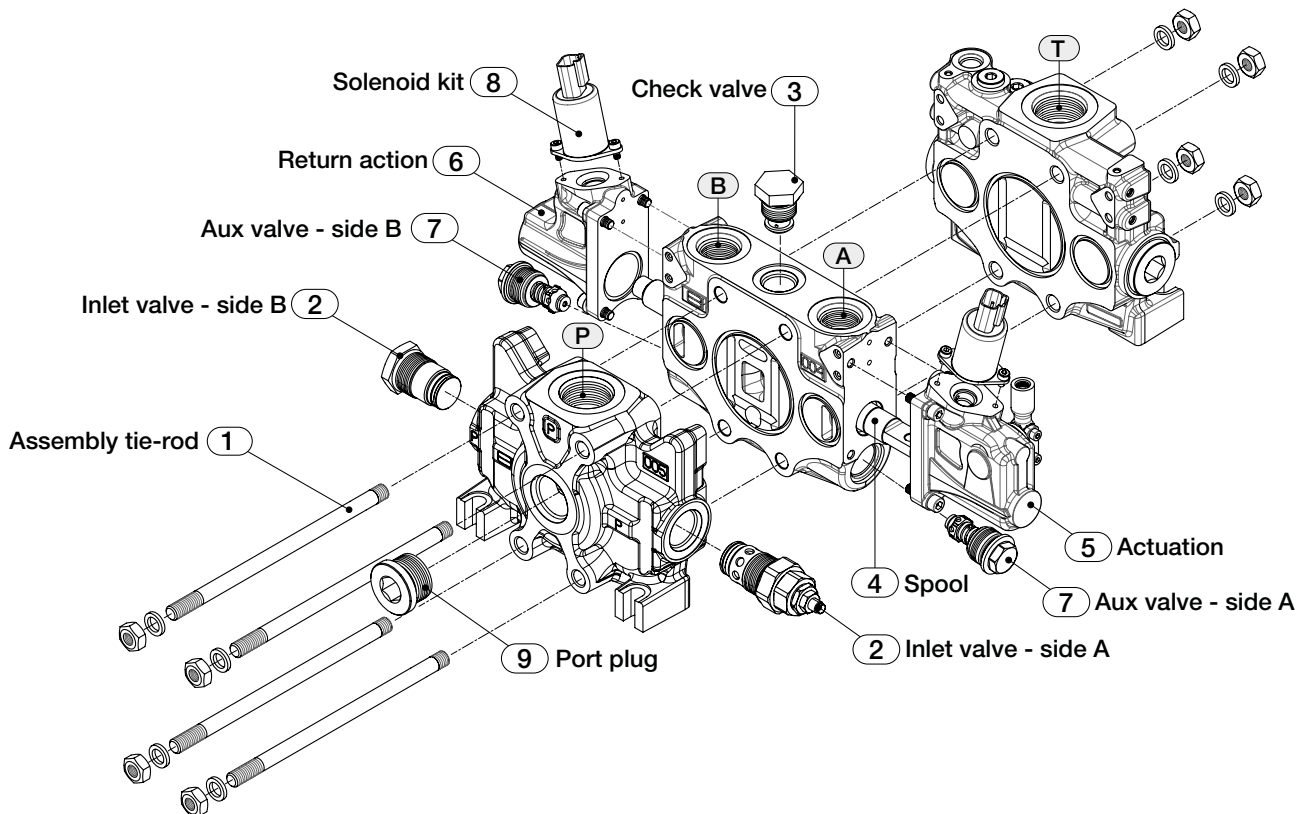

Note:

This example represents a ECS12A with standard left configuration, with single electrohydraulic section. All sectional ECS12A valves have symmetric bodies, thanks to this characteristics, it is possible to change the control side, by simply reversing the spool 180°. All valves can easily be changed from right inlet (R) to left inlet (L) and vice versa.

REFERENCE	CATALOGUE CODE	ORDER CODE	DESCRIPTION	NOTE
1	N1	A01010028	Tie rod for 1 work section	Each assembly contains: - 4 tie rods - 8 nuts - 8 growers.
	N2	A01010029	Tie rod for 2 work sections	
	N3	A01010030	Tie rod for 3 work sections	
	N4	A01010031	Tie rod for 4 work sections	
	N5	A01010032	Tie rod for 5 work sections	
	N6	A01010033	Tie rod for 6 work sections	
	N7	A01010034	Tie rod for 7 work sections	
	N8	A01010035	Tie rod for 8 work sections	
	N9	A01010036	Tie rod for 9 work sections	
	N10	A01010037	Tie rod for 10 work sections	
	N11	A01010038	Tie rod for 11 work sections	
	N12	A01010039	Tie rod for 12 work sections	

REFERENCE	CATALOGUE CODE	ORDER CODE	DESCRIPTION	NOTE
2	V02	VA0300001	Relief valve plugged	
	V01050	VA0205001	Pilot operated pressure relief valve (50 bar)	RANGE available: A) 50 - 350 bar For specific setting contact our sales department
	V01100	VA0210001	Pilot operated pressure relief valve (100 bar)	
	V01150	VA0215001	Pilot operated pressure relief valve (150 bar)	
	V01200	VA0220001	Pilot operated pressure relief valve (200 bar)	
	V01250	VA0225001	Pilot operated pressure relief valve (250 bar)	
	V01300	VA0230001	Pilot operated pressure relief valve (300 bar)	
	V01350	VA0235001	Pilot operated pressure relief valve (350 bar)	
	V03050	VA0105001	Direct acting pressure relief valve (50 bar)	RANGE available: A) 50 - 350 bar For specific setting contact our sales department
	V03100	VA0110001	Direct acting pressure relief valve (100 bar)	
	V03150	VA0115001	Direct acting pressure relief valve (150 bar)	
	V03200	VA0120001	Direct acting pressure relief valve (200 bar)	
	V03250	VA0125001	Direct acting pressure relief valve (250 bar)	
	V03300	VA0130001	Direct acting pressure relief valve (300 bar)	
	V03350	VA0135001	Direct acting pressure relief valve (350 bar)	

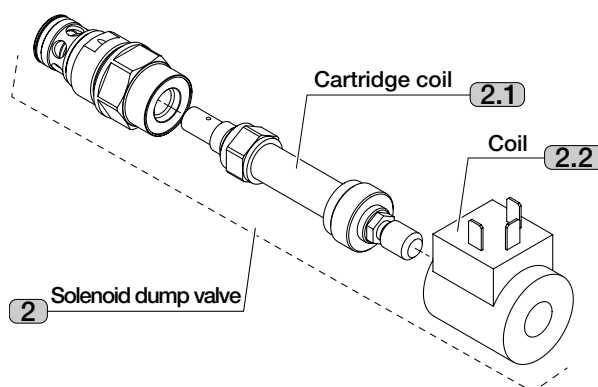

REFERENCE	CATALOGUE CODE	ORDER CODE	DESCRIPTION	NOTE
2	V0412A	VA0800005	Solenoid dump valve 12 VDC - AMP junior	
	V0424A	VA0800006	Solenoid dump valve 24 VDC - AMP junior	
	V0412D	VA0800003	Solenoid dump valve 12 VDC - DT04	
	V0424D	VA0800004	Solenoid dump valve 24 VDC - DT04	
	V0412H	VA0800001	Solenoid dump valve 12 VDC - DIN 43650	
	V0424H	VA0800008	Solenoid dump valve 24 VDC - DIN 43650	
	V06	VA0600001	Main anticavitation check valve	
2.1		C04020002	Cartridge coil	
2.2		C04010015	Coil 12 VDC AMP Junior	
		C04010016	Coil 24 VDC AMP Junior	
		C04010011	Coil 12 VDC DT04	
		C04010012	Coil 24 VDC DT04	
		C04010009	Coil 12 VDC DIN 43650	
		C04010010	Coil 24 VDC DIN 43650	



REFERENCE	CATALOGUE CODE	ORDER CODE	DESCRIPTION	NOTE
3		A01020001	Assembly check valve	
	S01N	A01150007	3 positions double acting	
4	S02N	A01150008	3 positions double acting A/B to tank	
	S03N	A01150009	3 positions single acting on A	
	S04N	A01150010	3 positions single acting on B	
	S05N	A01150011	4 positions double acting FLOAT	
	S11N	A01150016	3 positions double acting A blocked - B to tank	
	S12N	A01150017	3 positions double acting A to tank - B blocked	
	5	AM01	A01030001	Control lever
AM02		A01030001	Control lever rotated 180°	
AM05		A01030002	Control tang spool end	
AM20		A01030012	Control lever - FLOAT	only with S05N spool
AH01B		A01040017	Hydraulic actuation - SIDE ports G 1/4	Hydraulic actuation
AH01S		A01040014	Hydraulic actuation - SIDE ports SAE6	
AH02B		A01040004	Hydraulic actuation - UPPER ports G 1/4	
AH02S		A01040001	Hydraulic actuation - UPPER ports SAE6	
AH04B		A01040019	Hydraulic actuation - stroke limiter ports G 1/4	
AH04S		A01040018	Hydraulic actuation - stroke limiter ports SAE6	
AE01		A01080001	EH actuation with control lever	EH actuation
AE02		A01080005	EH actuation with lever and stroke limiter	
AE03		A01080006	EH actuation without lever	
AE04		A01080007	EH actuation without lever and stroke limiter	
AJ1L		A01110001	Joystick control - Fulcrum on 1 st section	Only for LEFT inlet (L)
AJ2L		A01110005	Joystick control - Fulcrum on 2 nd section	
AJ1R	A01110005	Joystick control - Fulcrum on 1 st section	Only for RIGHT inlet (R)	
AJ2R	A01110001	Joystick control - Fulcrum on 2 nd section		
6	RM01M	A01120001	Spring centered spool (spring MEDIUM)	
	RM01S	A01120003	Spring centered spool (spring SOFT)	
	RM01H	A01120002	Spring centered spool (spring HEAVY)	
	RM04M	A01130002	Detent in position 1/2	
	RM05M	A01130002	Detent in position 1	
	RM06M	A01130003	Detent in position 2	
	RM11M	A01130004	Detent in 4th position	only with S05N spool
	RM12	A01130005	Detent in position 1/0/2 without spring	
	RR01	A01050001	Proportional pneumatic (G 1/8)	
	RR03	A01050002	Proportional pneumatic (NPTF 1/8-27)	
	RE01	A01080002	Spool return for EH actuation	

REFERENCE	CATALOGUE CODE	ORDER CODE	DESCRIPTION	NOTE
7	V51050	VF0305001	Fixed setting combined valve (50 bar)	For specific setting contact our sales department
	V51100	VF0310001	Fixed setting combined valve (100 bar)	
	V51150	VF0315001	Fixed setting combined valve (150 bar)	
	V51200	VF0320001	Fixed setting combined valve (200 bar)	
	V51250	VF0325001	Fixed setting combined valve (250 bar)	
	V51300	VF0330001	Fixed setting combined valve (300 bar)	
	V51350	VF0335001	Fixed setting combined valve (350 bar)	
	V52	VF0100001	Fixed setting valve plugged	
	V53	VF0200001	Fixed setting anticavitation valve	
	V55	VA0300002	Adjustable valve plugged	
	V57050	VA0505004	Adjustable pilot combined valve (50 bar)	For specific setting contact our sales department
	V57100	VA0510004	Adjustable pilot combined valve (100 bar)	
	V57150	VA0515004	Adjustable pilot combined valve (150 bar)	
	V57200	VA0520004	Adjustable pilot combined valve (200 bar)	
	V57250	VA0525004	Adjustable pilot combined valve (250 bar)	
	V57300	VA0530004	Adjustable pilot combined valve (300 bar)	
	V57350	VA0535004	Adjustable pilot combined valve (350 bar)	
V59050	VF0405001	Fixed setting adjustable combined valve (50 bar)	For specific setting contact our sales department	
V59100	VF0410001	Fixed setting adjustable combined valve (100 bar)		
V59150	VF0415001	Fixed setting adjustable combined valve (150 bar)		
V59200	VF0420001	Fixed setting adjustable combined valve (200 bar)		
V59250	VF0425001	Fixed setting adjustable combined valve (250 bar)		
V59300	VF0430001	Fixed setting adjustable combined valve (300 bar)		
V59350	VF0435001	Fixed setting adjustable combined valve (350 bar)		
8	K12A	A01240005	Coil kit Junior timer (AMP84-9419) 12 VDC	Each work section requires 2 coil kit
	K24A	A01240006	Coil kit Junior timer (AMP84-9419) 24 VDC	
	K12D	A01240003	Coil kit DEUTSCH DT04-2P 12 VDC	
	K24D	A01240004	Coil kit DEUTSCH DT04-2P 24 VDC	
	K12H	A01240001	Coil kit DIN - 12 VDC	
	K24H	A01240002	Coil kit DIN - 24 VDC	
9		C03010006	Port plug G 1/2	
		C03010008	Port plug G 3/4	
		C03010010	Port plug G 1	
		C03010005	Port plug SAE10	
		C03010007	Port plug SAE12	
		C03010009	Port plug SAE16	



ORDER CODE	DESCRIPTION
A01190002	assembly gasket MANUAL section

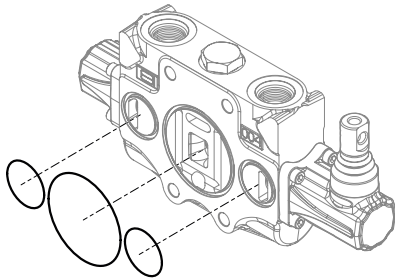

ORDER CODE	DESCRIPTION
A01190001	assembly gasket EH section

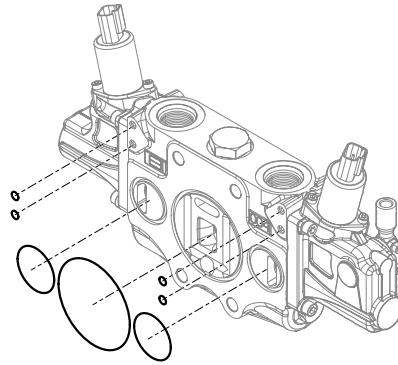

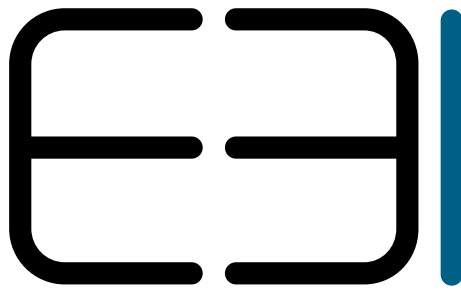

engineering beyond imagination

EBI MOTION CONTROLS S.r.l

Via Andrea Costa 11/2 40057
Cadriano Fraz. di Granarolo dell'Emilia (BO)
TEL. +39 051.0188.800
FAX 051.701.093

info@ebimc.com
www.ebimc.com