



Monoblock directional control valve

ECM08B

Rev. 04 • January, 2025

TECHNICAL CATALOGUE



.....
Controls



HISTORY OF REVISIONS

DATE	PAGE	CHANGED	REV.
May, 2019	-	First edition	00
November, 2019	16-17-19-20-21-23-24	Introduced the choice of the number of sections	01
July, 2023	24-25-26	Introduced Joystick control actuation and Push-Push actuation	02
September, 2024	32-33-34	Spare parts list added	03
January, 2025	24-25	Modified operating curve and updated technical specifications of PSH-PUSH actuation	04

ABOUT THE MANUAL

This manual contains the technical instructions for the monoblock directional control valve ECM08B. All information given in this manual is current and valid according to the information available at the time of publication. The data specified above only serve to describe the product. EBI Motion controls reserves to modify or revise the instructions without prior notice.

EBI Motion controls is not responsible for any damage caused by an incorrect use of the product. Please visit www.ebimc.com for the most recent version of this manual.

CONTENTS

4	INTRODUCTION
5	GENERAL INFORMATION
6	APPLICATION AND SAFETY GUIDELINES
9	HYDRAULIC FLUID
11	PORT DETAILS
12	DIMENSIONS
13	TECHNICAL SPECIFICATIONS
	TECHNICAL DATA
14	TYPICAL CURVES
16	ORDERING CODES
	BODY CLASSIFICATION
	INLET ARRANGEMENT
	WORK SECTION
	OPTION
	ACCESSORIES
	GENERAL CLAMPING TORQUE
32	SPARE PARTS LIST





INTRODUCTION

CONTROLS

EBC motion controls provides a broad choice of directional monoblock control valves expertly developed and tested to meet different market sectors' needs. EBC Control valves are suited for specialized applications for a variety of mobile equipment such as:

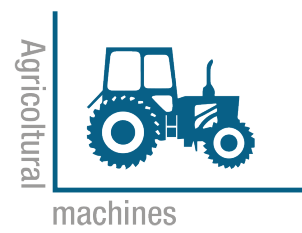
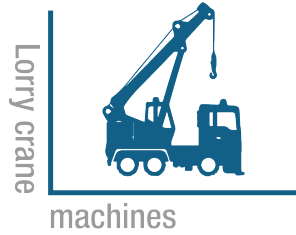

ECM08B

MONOBLOCK DIRECTIONAL CONTROL VALVE

- From 1 to 7 working sections.
- Low internal leakage.
- Compact directional valve with low pressure losses.
- Interchangeable spools.
- Availability of manual, hydraulic, and pneumatic actuations.



GENERAL INFORMATION

HYDRAULIC OPERATING PRINCIPLE

ECM08B are directional control valves of monoblock design. They give fine control of the speed and direction of oil flow. The valve are operated manually, hydraulically or pneumatically, as required.

They basically consist of an arrangement body, spool, check valve, spool actuation, spool return action and direct relief valve.

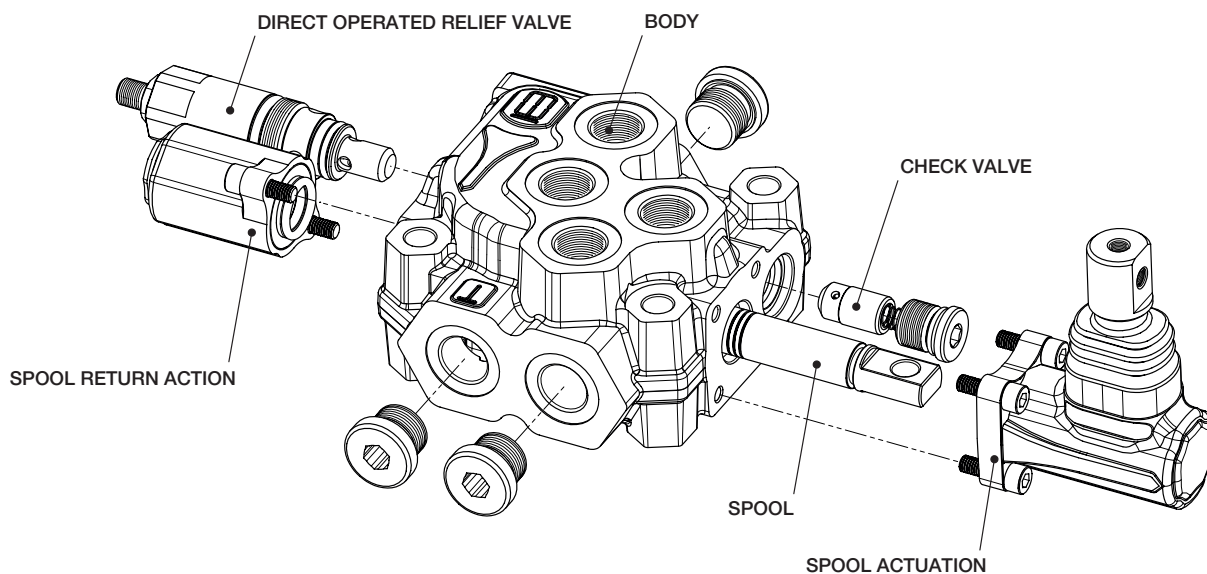

In the unoperated condition, the spool is held in starting position by the return spring. In this position the connection from pump to service is closed. When the spool is operated it intercepts the switch gallery end diverts the oil flow to service ports **A** or **B**. If two or more spools are actuated at the same time, the oil will power the service port which has the lower load by selecting the path with the least resistance; by throttling the spools, the flow of oil can be divided between two or more service ports (**Parallel circuit**).

CARRYOVER CONNECTION (HPCO)

This option allows the switch gallery to be extended outside in order to power a second directional control valve in series. A directional control valve configured in this manner requires an unloading circuit (T) for the work ports.

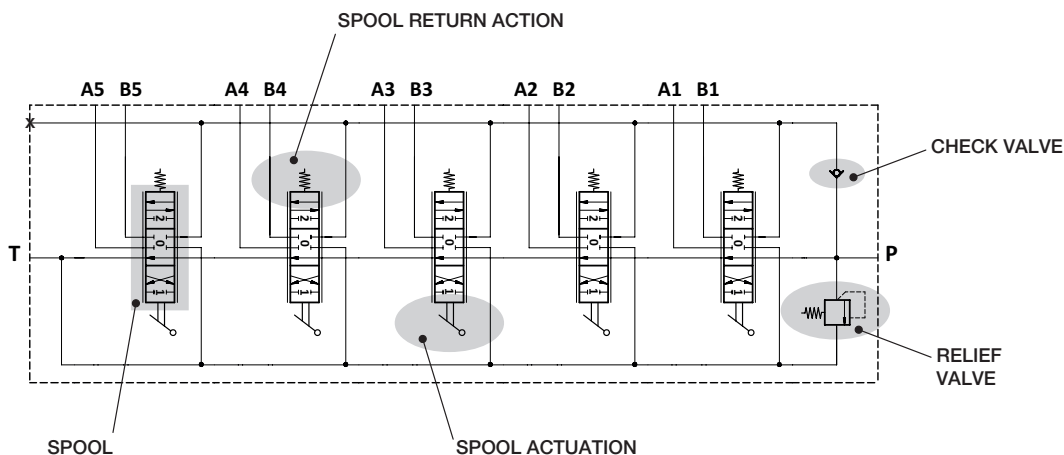

ECM08B/5 with manual actuation in standard configuration.

APPLICATION AND SAFETY GUIDELINES

INTENDED USE

Monoblock directional control valve ECM08B is designed for industrial use.

WARRANTY

Check the package and the product for transport damage when receiving goods. The package is not meant for long term storage; protect the product appropriately. Do not dismantle the product. The warranty is void if the product has been disassembled. The manufacturer is not responsible for damages resulting from misinterpreted, non compliance, incorrect, or improper use of the product that goes against the instructions given in this document.

GENERAL SAFETY INSTRUCTIONS

The following instructions apply to all procedures associated with the product. Read these instructions carefully and follow them closely.

- Use necessary personal protective equipment when working with the product.
- Support the product properly; make sure the product cannot fall over or turn around by accident.
- Use only appropriate equipment and attachments for lifting and transferring the product.
- Prevent unintended use of the product during installation and maintenance procedures.
- Never use the Control Valve at a pressure exceeding the rated pressure.
- Use the Control Valve within the rated flow; if not there might be malfunction or a deterioration in heat balance.
- Using low-cleanliness hydraulic fluid might cause seal failure or damage to the seal part, resulting in operation failure, or operation mistake of the machine; the customer is requested to check the cleanliness of the hydraulic fluid.

WARNING SYMBOL

The following symbols can be used in this manual:



Note:
Useful
information



Danger:
Danger of death
or injury



Attention:
May cause damage
to the product

STORAGE OF NEW PRODUCT

Encapsulated by a protective wrapping, the control valve ECM08B shall not be exposed to direct sunlight nor to source of heat or ozone and kept in a dry place at a temperature between -20°C $+50^{\circ}\text{C}$ [-4°F $+122^{\circ}\text{F}$].

Do not store the product in:

- Places where it might be damaged;
- Very hot/humid areas;
- Where it could get wet;
- Where it could come into contact with organic solvents, acids, alkalis and/or dangerous gases;
- In places subject to sudden, significant changes in temperature.

EBI motion control is not responsible for any damages due to a storage not in compliance with our prescriptions; For any doubts, please contact our aftersales office.

SAFETY GUIDELINES

During any operation on product ECM08B, it is recommended to pay attention to components surfaces temperature. The circuit functions are to be so designed that uncontrolled machine movements, caused by the application, are prevented and that it is possible to switch from one function to another. Take into account all of the application limits, particularly those application limits stated within this technical catalogue.

It is recommended to follow these steps and only trained and competent personnel may carry out any work on ECM08B Control Valve:

- Do not direct the jet of a pressure washing unit directly to the product
- Ensure that all matching surfaces are clean, without contamination.

- Ensure that all seals and back-up rings for the matching surfaces are flawless and correctly placed.
- Do not put any sealing material other than the standard seals.
- During the assembly of the complete Control Valve, refer to the hydraulic scheme and to the name assigned to each port.
- Use gloves in order to avoid accidental injuries during installation or maintenance.
- Do not grab / handle product from moving parts (i.e. cables, levers,...etc.)
- All Control Valve are attributable to pressure vessels. It's always recommended to place the components in a closed but ventilated compartment, able to protect the environment and users in case of accidental ejection of material under pressure (fittings, pipes, plugs, expander,...etc.)
- Before removing or disassembling the complete Control Valve or allowed parts (as pressure gauge ports, plugs) it is strongly recommended to vent all hydraulic pressure from the system.
- During the first start of the machine, please ensure that the grounding system is connected and stay away from moving parts.

HANDLING PRECAUTIONS

If the Control Valve doesn't work in the adequate way, we advise you to contact our Aftersales office. However if the disassembly and assembly operations are strictly unavoidable, you must observe the following prescriptions and charge the carrying out of the operations to technicians highly qualified in hydraulic field.

- The Control Valve reaches high temperature after operating the machine; start the work only after checking that the temperature is low;
- The valve can hold high internal pressure; release the inside pressure and ensure all machine actuators are in a rest position before removing the piping. In any case safely and carefully unscrew connections and fittings.
- Since hydraulic devices are all machined precisely with very accurate clearances, carry out the disassembly and assembly work at a clean place;
- Before disassembly work, get the assembly instructions by requiring to our aftersales office and prepare all the material needed for the task;
- To disassemble and assemble the valve observe strictly our mounting instructions;
- Since there is the possibility of rust when the disassembled parts are left, apply anticorrosive oil to the parts and seal them;
- Before remounting the Control Valve on the operating machine, ensure that the Control Valve has not been affected by carrying out various hydraulic tests (e.g. Relief Valve setting, Leak test..).



Attention:

Always bear in mind that "all workers must act responsibly to ensure their own health and safety"; use of personal protection equipment is therefore essential. All the disassembly and assembly operations must observe strictly the procedures listed in the EBI procedures. EBI motion control is not responsible for any damages due to disassembly and assembly procedures not in compliance with our prescriptions. For any doubts, please contact our aftersales department.

INSTALLATION PROCEDURES

When receiving the Control Valve make sure you:

- Check if there are some sign of damage of the packaging;
- Check that the dimensions of the product seat are compatible with those of the product itself;
- Remove the plastic caps that protect the service ports and be careful not to introduce any dirt or foreign object inside the control valve as this could damage it;
- Mount the control valve securely to a flat surface (recommended 3 point fixing); at the time do not use a hammer to positioning by hitting; any distortion in assembly can result in spool sticking and poor control;
- Clean piping materials sufficiently before use;
- Prevent the port openings from being entered with dust or foreign matters;
- tighten the port connectors safely with the recommended fastening torques;
- If possible, install the valve in a protected environment, avoiding direct exposure to weathering, water, salt or any other corrosion substances.



FITTINGS TIGHTENING TORQUE (Nm)

Do not tighten fittings with torque higher than the recommended value; otherwise there might be strains or damage to control valve possibly leading to serious accident.

If the pipings are not connected to the correspondent ports, unintentional movements might cause a serious accident; EBI motion control is not responsible for any damages due to an installation procedure not in compliance with our procedures.

SPECIFICATIONS	PORT (P)	PORT (A-B)	PORT (T)
BSP THREADS ISO 1179-1	G 3/8	G 3/8	G 3/8
<i>with rubber saling (din 3869)</i>	40	40	40
<i>with copper or steel and rubber washer</i>	40	40	40
UN/UNF THREADS ISO 11926-1	3/4" 16 UNF	3/4" 16 UNF	3/4" 16 UNF
<i>with o-ring</i>	40	40	40

PRODUCT IDENTIFICATION

The product identification data can be found on the identification plate attached to the EBI product.

SERIAL NUMBER

all manufacturing data and all sales data can be found with the serial number

PART NUMBER CODE

It is a number univocally identifying the configuration and pressure setting of a valve



Note:

Serial number and part number code have 9 characters (letters and numbers).

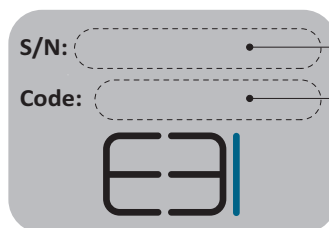

AREA FOR SERIAL NUMBER CODE

AREA FOR PART NUMBER CODE



Attention:

These guidelines are not intended to be considered as complete

HYDRAULIC FLUID

Mineral oil based hydraulic fluids suitable for hydraulic systems can be used; they should have physical lubricating and chemical properties as specified by:

MINERAL OIL BASED HYDRAULIC FLUIDS HL (DIN 51524 part 1)

MINERAL OIL BASED HYDRAULIC FLUIDS HLP (DIN 51524 part 2)

For use of environmentally friendly fluids (vegetable or polyglycol base), or other fluids, please contact EBI.

OIL AND SOLUTIONS - ISO 6743/4	(°C) MIN	(°C) MAX
Mineral Oil HL, HM or HLP	-25	+80
Oil in water emulsion HFA	+5	+55
Oil in water emulsion HFB	+5	+55
Polyglycol-based aqueous solution HFC	-10	+60

Hydraulic fluids are available in different viscosity classes identified by the ISO VG number, which corresponds to the kinematic viscosity at 40°C. Here is a table showing typical viscosity changes between 0°C and 100°C for mineral oil based fluids having various viscosity classes. The fluid should be selected with the aim to achieve an appropriate operating viscosity at the expected working temperature.

Viscosity class	VISCOSITY CLASS AND FILTRATION DATA		
	kinematic viscosity (cSt)		
	maximum (0° C)	medium (40° C)	minimum (100° C)
ISO VG 10	90	10	2.4
ISO VG 22	300	22	4.1
ISO VG 32	420	32	5.0
ISO VG 46	780	46	6.1
ISO VG 68	1400	68	7.8
ISO VG 100	2560	100	9.9

FLUID CLEANLINESS REQUIREMENTS

The cause of malfunctions in hydraulics is often found to be excessive fluid contamination. The hard contaminant particles in the fluid wear the hydraulic components and prevent the poppets from re-seating, with consequent internal leakage and system inefficiency. For the correct operation it is necessary to adopt filtration methods which guarantee for life the specified fluid cleanliness level. It is important to ensure that hydraulic fluids are brought to the appropriate cleanliness level prior filling up the systems, and, when in doubt, also to flush the hydraulic components prior to installation.

FILTRATION RATIO $BETA_x$:

It is the ratio between the number of particles before and after the filter with diameter larger than X micron.

ABSOLUTE FILTRATION RATIO ISO 4572:

It is the diameter X of the largest particle with $BETA_x \geq 75$.

CONTAMINATION CLASS ISO 4406:

It is expressed by 3 scale numbers representing respectively: the number of particles equal to or larger than 4µm, the number of particles equal to or larger than 6µm, the number of particles equal to or larger than 14µm contained in 1 ml of fluid.

CONTAMINATION CLASS NAS 1638:

It is expressed by one scale numbers representing the number of particles of different size ranges contained in 1 ml of fluid.

**FILTRATION RECOMMENDATION**

Type	Nominal filtration (micron)	Absolute filtration rating ISO 4572 (BETA _x ≥75)	Contamination class	
			ISO 4406	NAS 1638
System/components operating at <i>HIGH PRESSURE > 250 bar</i> <i>HIGH DUTY CYCLE APPLICATIONS</i> Systems/components with <i>LOW dirt tolerance</i>	10	X = 10... 12	19/17/14	8
System/components operating at <i>MEDIUM HIGH PRESSURE</i> <i>HIGH DUTY CYCLE APPLICATIONS</i> Systems/components with <i>MODERATELY dirt tolerance</i>	15	X = 12... 15	20/18/15	9
System/components operating at <i>LOW PRESSURE < 100 bar</i> <i>LOW DUTY CYCLE APPLICATIONS</i> Systems/components with <i>GOOD dirt tolerance</i>	25	X = 15... 25	21/19/16	10

**Attention:**

If the filtration demands are not met, the valve poppets can jam in the open position, with the result that the valve remains actuated. It is not possible to force back jammed poppets mechanically.

PORT DETAILS

The connection port size is indicated by an ordering code common for all EBI products. Following tables show all available connections.

BSP THREADS ISO 1179-1	D	C		B		A		CODE
	UNI-ISO 228	mm	in	mm	in	mm	in	
	G 1/4	13	0.51	19	0.75	1	0.094	1B
G 3/8	13	0.51	25	0.98	1	0.04	2B	
G 1/2	15	0.59	29	1.14	1.5	0.06	3B	
G 3/4	17	0.67	36	1.42	1.5	0.06	4B	
G 1	19	0.75	45	1.77	2	0.08	5B	

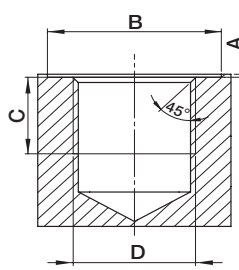

UN/UNF THREADS ISO 11926-1	D	C		B		L		M		K	A		CODE
	ASA-B1-1	mm	in	mm	in	mm	in	mm	in		mm	in	
	9/16-18 UNF (SAE6)	13	0.51	26	1.02	15.6	0.61	2.5	0.098	12°	1	0.04	1S
3/4-16 UNF (SAE8)	15	0.59	30	1.18	20.6	0.81	2.6	0.102	15°	1.5	0.06	2S	
7/8-14 UNF (SAE10)	17	0.67	34	1.34	23.9	0.94	2.6	0.102	15°	1.5	0.06	3S	
1"1/16-12 UNF (SAE12)	20	0.79	41	1.61	29.2	1.15	3.3	0.13	15°	1.5	0.06	4S	
1"5/16-12 UNF (SAE16)	20	0.79	50	1.97	35.5	1.40	3.3	0.13	15°	2	0.08	5S	

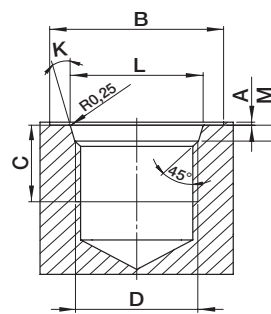



DIMENSIONS

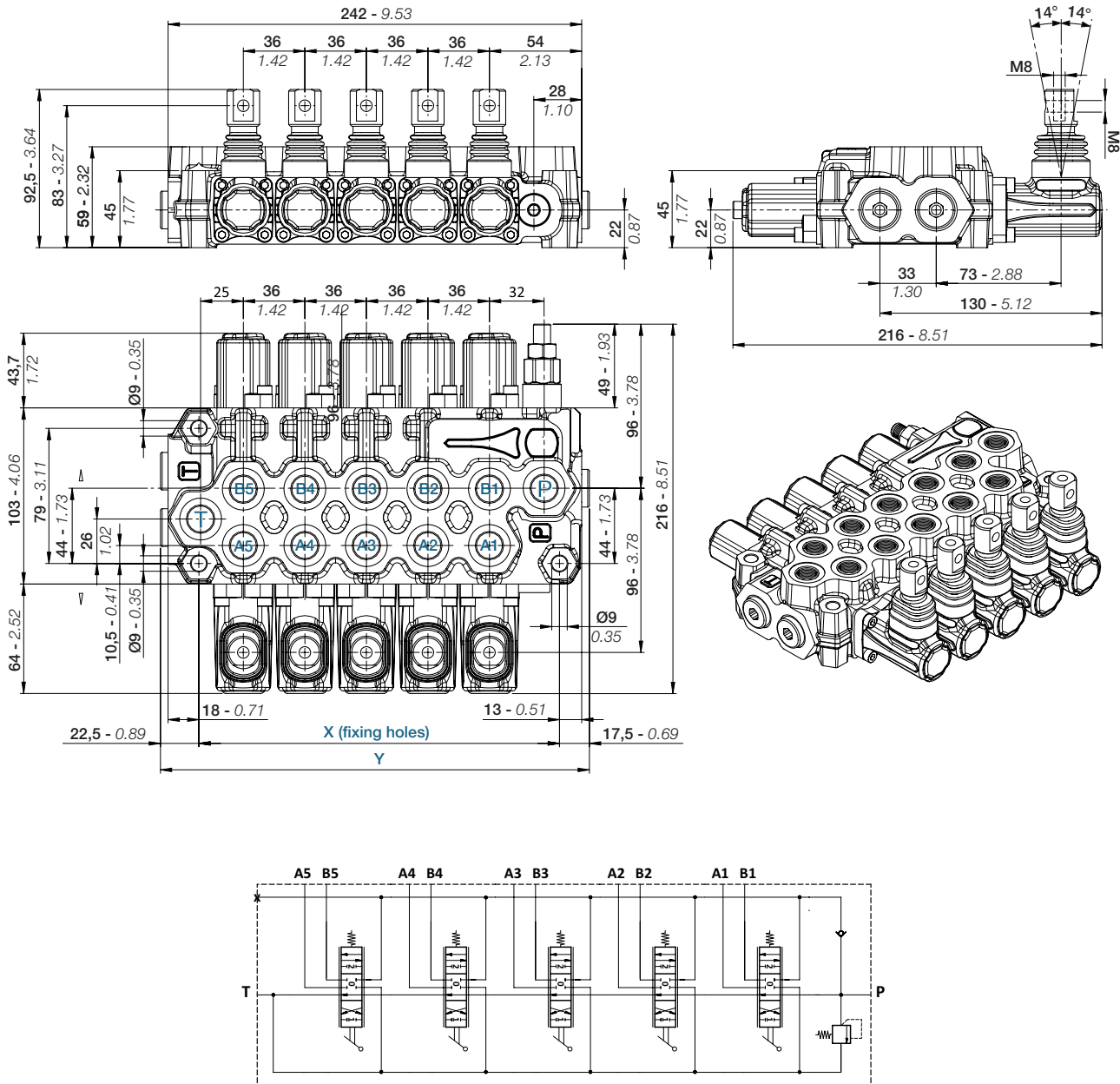

STANDARD CONNECTIONS

TYPE	BSP (ISO 1179-1)	UN-UNF (ISO 11926-1)
INLET - P	G 3/8	3/4" - 16 UNF
PORTS - A / B	G 3/8	3/4" - 16 UNF
OUTLET - T / T1 / HPCO	G 3/8	3/4" - 16 UNF
Pneumatic pilot	G 1/8	NPTF 1/8-27
Hydraulic pilot	G 1/4	9/16" - 18 UNF

TECHNICAL SPECIFICATIONS

TYPE	X	Y		WEIGHT
		mm - [in]	mm - [in]	
ECM08B/1	67 - [2.64]	107 - [4.22]	3,2 - [7.1]	
ECM08B/2	103 - [4.06]	143 - [5.63]	4,4 - [9.7]	
ECM08B/3	139 - [5.48]	179 - [7.05]	5,6 - [12.3]	
ECM08B/4	175 - [6.90]	215 - [8.47]	6,8 - [15.0]	
ECM08B/5	211 - [8.31]	251 - [9.89]	8,0 - [17.6]	
ECM08B/6	247 - [9.73]	287 - [11.3]	9,2 - [20.3]	
ECM08B/7	283 - [11.15]	323 - [12.73]	10,4 - [22.9]	

TECHNICAL DATA

All performances in this catalogue are obtained using mineral based hydraulic oil 46 cSt viscosity at 40°C (ISO VG 46 viscosity class). All ECM08B go through functional testing at these conditions before shipment.

HYDRAULIC STANDARD SPECIFICATIONS

Nominal Flow range	50 l/min - [12 GPM]
Nominal pressure	350 bar - [5000 psi]
Hysteresis	< 1 bar - [14,5 psi]
Hydraulic fluid	Mineral Oil HL, HLP (DIN 51524); phosphate ester (HFD-R)
Fluid temperature range	-20°C +80°C [-4°F +176°F]
Fluid viscosity range	10 ÷ 380 cSt
Max contamination level	9 (NAS 1638) - 20/18/15 (ISO 4406:1999)
Recommended filtration	B10 > 75 (ISO 16889:20008)

MATERIAL STANDARD SPECIFICATIONS SEALS

O-Rings: **Buna N** (acrylonitrile butadiene), also named **NBR** (according to ASTM), compatible with fluids having mineral oil base, water in oil emulsions, and water glycol fluids.

These seals are standard for temperatures within the range -20°C and +80°C

Back-up rings and Slide rings: **strengthened PTFE** (Politetrafluoroetilene like Teflon®, Lubriflon®, Ecoflon®, or similar). Special FPM (Viton®) seals are available on request.

Note: the seal materials are compatible with the fluids normally used in hydraulic systems; in case of special fluids, if you suspect incompatibility between the fluid used and the standard seals, contact the EBI motion controls service network.

UNITS OF MEASURE - CONVERSION FACTORS

LENGHT	FLOW RATE	MASS	FORCE WEIGHT	PRESSURE
1 mm = 0,0394 in	1 l = 0,2200 gal UK	1 kg = 2,205 lb	1 Nm = 0,1020 Kgf	1 bar = 100000 Pa
1 in = 25,4 mm	1 l = 0,2642 gal US	1 lb = 0,4536 kg	1 Kgf = 9,8067 Nm	1 bar = 14,5 psi
	1 gal UK = 4,546 l			1 Pa = 0,0001 bar
	1 gal UK = 1,2010 gal US			1 Pa = 0,00014 psi
	1 gal US = 3,785 l			1 psi = 0,0689 bar
	1 gal US = 0,8327 gal UK			1 psi = 6890 Pa



TYPICAL CURVES

PERFORMANCE DATA - PRESSURE DROP (P-T)

Pressure characteristic as function of flow

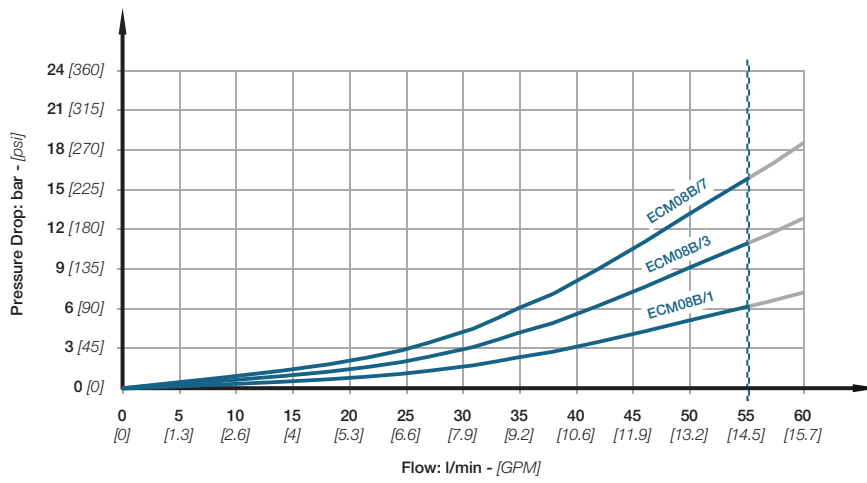

PERFORMANCE DATA - PRESSURE DROP (P-A/B)

Pressure characteristic as function of flow

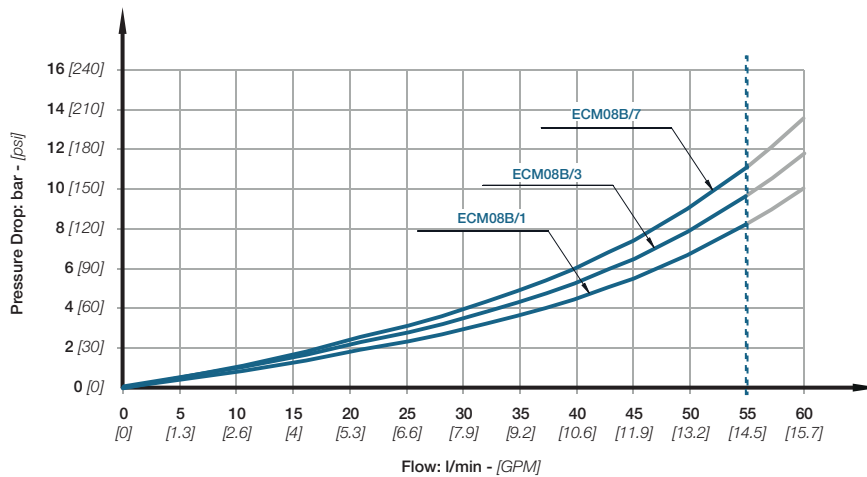

PERFORMANCE DATA - PRESSURE DROP (A/B-T)

Pressure characteristic as function of flow

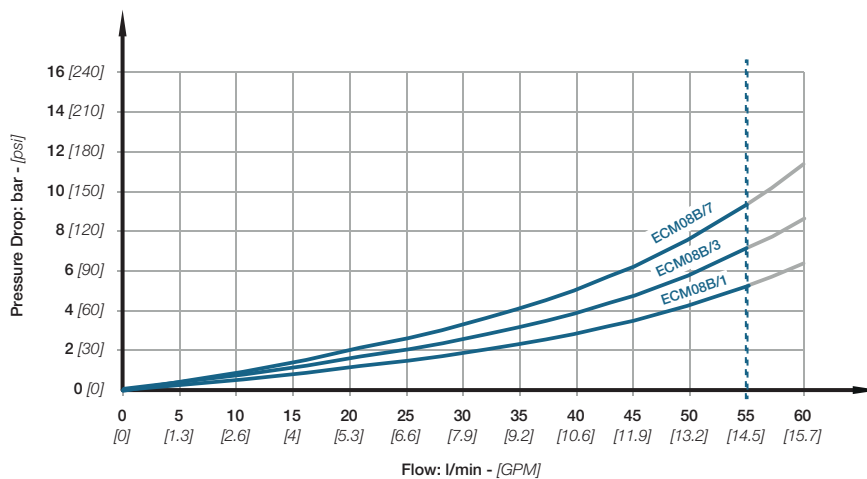

PERFORMANCE DATA - DIRECT ACTING PRESSURE RELIEF VALVE (V03)
 Pressure characteristic as function of flow

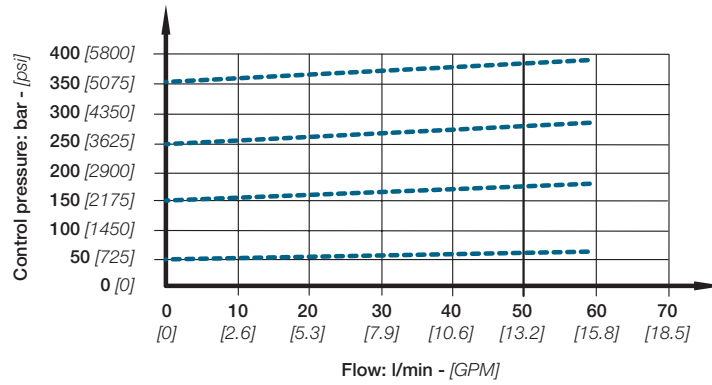

ORDERING CODES

The order code below provides an example of **Monoblock control valve ECM08B** with standard configuration. This example represents a ECM08B with manual actuation, main relief valve and body with BSP arrangement. Ordering code in position 5, 6 and 7 must be repeated for every work section. See page 17 - 29 for more informations about the different options available.

product	1	2	3	4	5	6	7	8
E C M 0 8 B	R	N 1	M 1 A 2 B	V 0 3 1 5 0	S 0 1 N	A M 0 1	R M 0 1 M	X 1

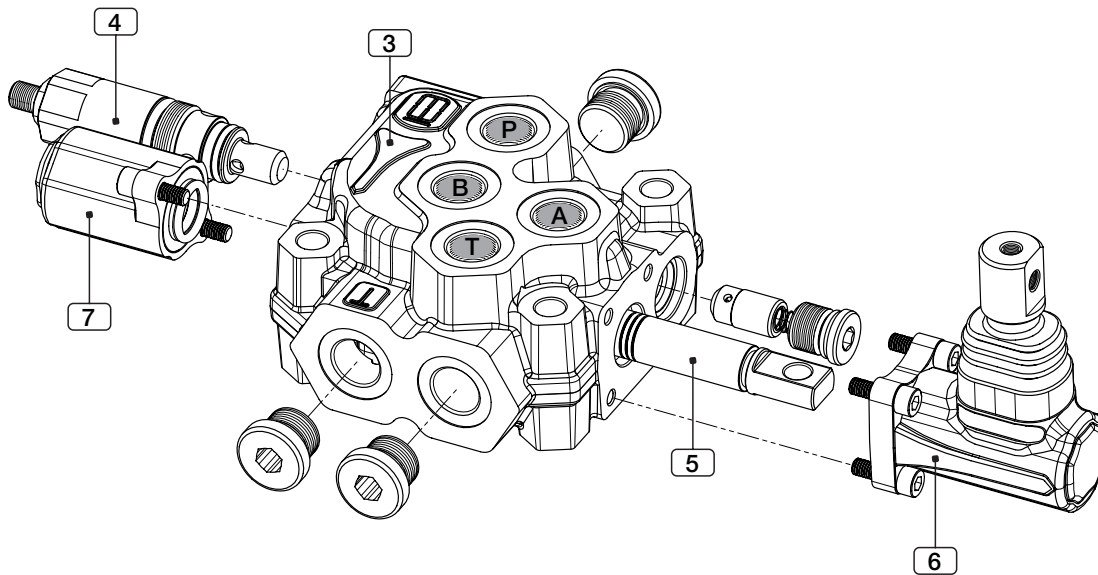

POSITIONS	CODE	DESCRIPTION	PAGE
	ECM08B	Product	
1	R	Inlet side	
2	N1	Section number	17
3	M1A2B	Monoblock body arrangement	18
4	V03150	Main relief valve	20
5	S01N	Spool	21
6	AM01	Actuation kit	22
7	RM01M	Return action kit	27
8	X1	Painted option	29



Note:

All arrangement monoblock bodies are equipped with one check valve.

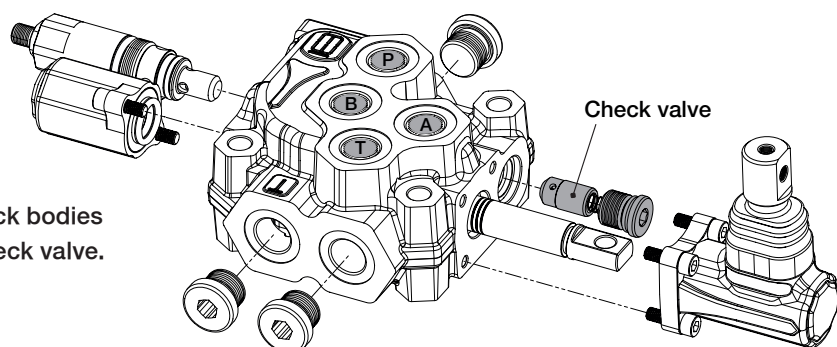

On all monoblock ECM08A valves it is possible to choose a RIGHT or LEFT inlet.

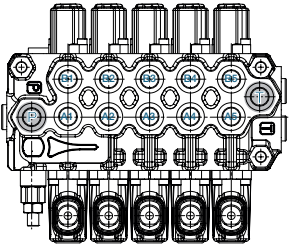
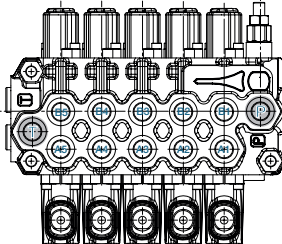
CODE	DESCRIPTION	DRAWING	CODE	DESCRIPTION	DRAWING
L	Inlet side LEFT		R	Inlet side RIGHT	

Convention for all ECM08B valves with inlet right (R) or left inlet (L):

- side A = spool actuation side
- side B = spool return action side.

You can configure a ECM08B from 1 to 7 work sections

CODE	DESCRIPTION
N1	Monoblock with 1 work section
N2	Monoblock with 2 work sections
N3	Monoblock with 3 work sections
N4	Monoblock with 4 work sections
N5	Monoblock with 5 work sections
N6	Monoblock with 6 work sections
N7	Monoblock with 7 work sections

BODY CLASSIFICATION

product		1	2	3	4	5	6	7	8																									
E	C	M	0	8	B	R	N	1	M	1	A	2	B	V	0	3	1	5	0	S	0	1	N	A	M	0	1	R	M	0	1	M	X	1

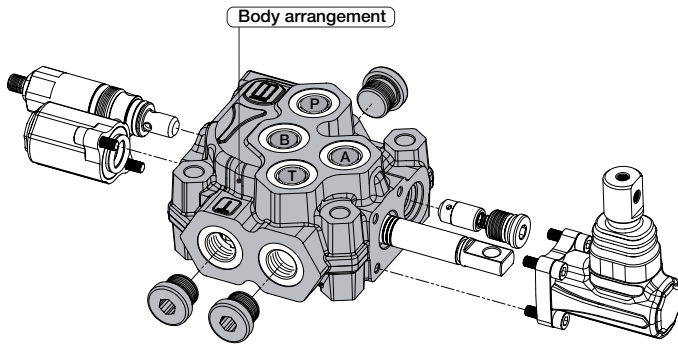

Moboblock control valve body arrangement is available in two configurations: SAE thread or BSP thread. All threads present in each body are equal.

It is possible to have two configurations type:

- **simple T port** (standard version)
- **carryover connection** (HPCO version)

The maximum flexibility of the body configuration is guaranteed by the positioning of the service ports plug. For different applications, contact our Sales Office.

STANDARD VERSION

CODE	DESCRIPTION	DRAWING
M1A2S	Monoblock body with upper ports P-T <i>3/4"-16 UNF (SAE8)</i>	
M1A2B	Monoblock body with upper ports P-T <i>G 3/8</i>	
M1B2S	Monoblock body with side ports P-T <i>3/4"-16 UNF (SAE8)</i>	
M1B2B	Monoblock body with side ports P-T <i>G 3/8</i>	
M1C2S	Monoblock body with upper port P and side port T <i>3/4"-16 UNF (SAE8)</i>	
M1C2B	Monoblock body with upper port P and side port T <i>G 3/8</i>	
M1D2S	Monoblock body with side port P and upper port T <i>3/4"-16 UNF (SAE8)</i>	
M1D2B	Monoblock body with side port P and upper port T <i>G 3/8</i>	

HPCO VERSION - CARRYOVER CONNECTION

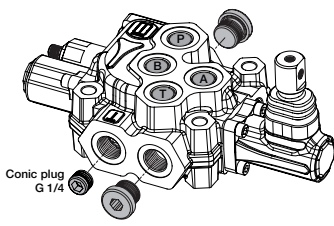
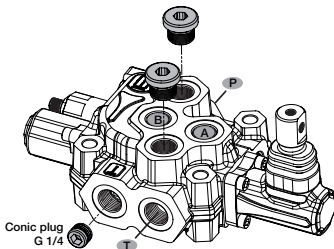
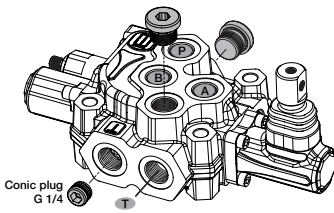
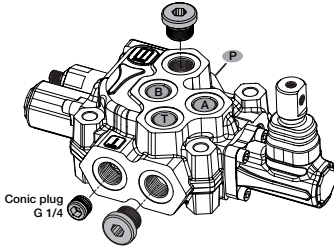
CODE	DESCRIPTION	DRAWING
M2A2S	Monoblock body with upper ports P-T side port HPCO <i>3/4"-16 UNF (SAE8)</i>	 <p>Conic plug G 1/4</p>
M2A2B	Monoblock body with upper ports P-T side port HPCO <i>G 3/8</i>	
M2B2S	Monoblock body with side ports P-T-HPCO <i>3/4"-16 UNF (SAE8)</i>	 <p>Conic plug G 1/4</p>
M2B2B	Monoblock body with side ports P-T-HPCO <i>G 3/8</i>	
M2C2S	Monoblock body with upper port P and side ports T-HPCO <i>3/4"-16 UNF (SAE8)</i>	 <p>Conic plug G 1/4</p>
M2C2B	Monoblock body with upper port P and side ports T-HPCO <i>G 3/8</i>	
M2D2S	Monoblock body with side ports P-HPCO and upper port T <i>3/4"-16 UNF (SAE8)</i>	 <p>Conic plug G 1/4</p>
M2D2B	Monoblock body with side ports P-HPCO and upper port T <i>G 3/8</i>	



Note:

All ECM08B can be easily trasformed from simple T port to HPCO configuration just by installing a conic plug G 1/4. These examples represent monoblock body in configuration M2A2B.

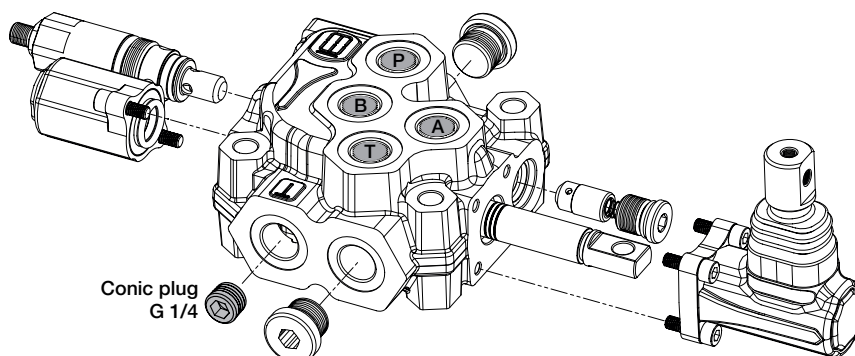

VALVE ARRANGEMENT

product				1	2	3				4			5	6			7			8														
E	C	M	0	8	B	R	N	1	M	1	A	2	B	V	0	3	1	5	0	S	0	1	N	A	M	0	1	R	M	0	1	M	X	1

INLET VALVE CLASSIFICATION

All monoblock control valve can be equipped with plug or direct acting relief valve; in the following table the available valves are shown. Valve type V03 requires factory setting (V03150); 150 is a value expressed in bar

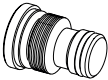
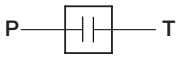
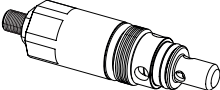
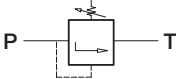
CODE	DESCRIPTION	DRAWING	SYMBOL	SETTING RANGE
V02	Relief valve plugged			
V03	Direct acting pressure relief valve			50 - 110 bar 111 - 160 bar 161 - 250 bar 251 - 350 bar

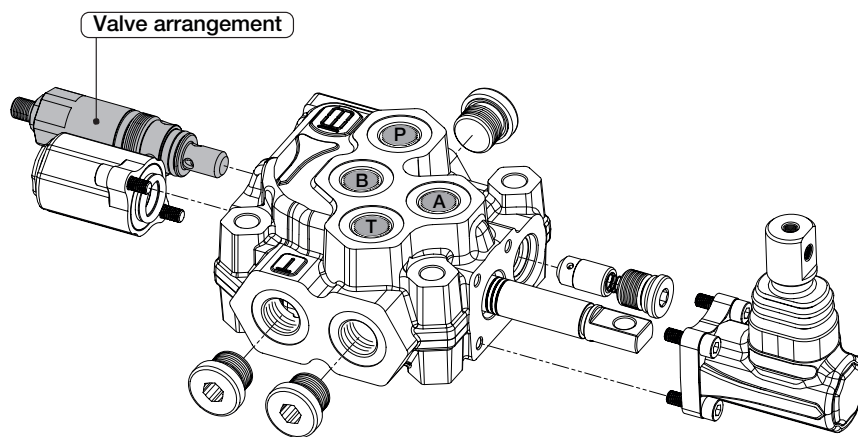

Note:

On request are available externally piloted valve, solenoid dump valve (12-24 Vdc) or clamping valve. These applications needs a special monoblock body with dedicated machining. For further informations, please contact our Sales Office.

WORK SECTION

product					1	2	3			4			5		6		7			8														
E	C	M	0	8	B	R	N	1	M	1	A	2	B	V	0	3	1	5	0	S	0	1	N	A	M	0	1	R	M	0	1	M	X	1

SPOOL CLASSIFICATION

Each ECM08B section contains a spool.
 Each spool is compatible with all actuations.
 All spools are perfectly interchangeable.

Example with spool 3 position double acting:

S01N Nominal flow (50 l/min)

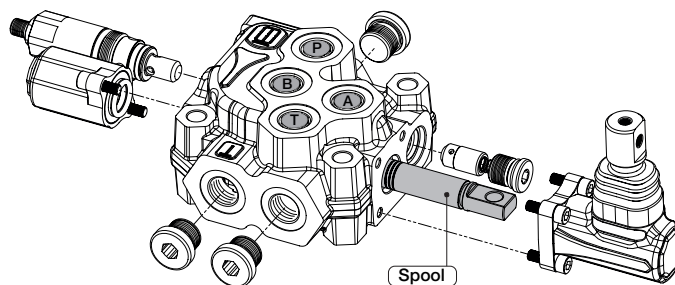

CODE	DESCRIPTION	SYMBOL
S01	Spool 3 positions double acting	
S02	Spool 3 positions double acting A/B to tank	
S03	Spool 3 positions single acting on A	
S04	Spool 3 positions single acting on B	
S05	Spool 4 positions double acting with float in 4th position	
S11	Spool 3 positions double acting A to tank - B blocked	
S12	Spool 3 positions double acting A blocked - B to tank	



Note:

The spools shown correspond to standard configuration; all section with single acting spool include plug to close the unused port. For different applications, please contact our Sales Office.

WORK SECTION

product				1	2	3			4			5			6			7			8													
E	C	M	0	8	B	R	N	1	M	1	A	2	B	V	0	3	1	5	0	S	0	1	N	A	M	0	1	R	M	0	1	M	X	1

SPOOL ACTUATION CLASSIFICATION

Monoblock valve ECM08B is available with manual or pneumatic controls.

Each mechanical actuation requires the choice of spool return action (side B).

Leave out the spool return action code when choosing hydraulic actuation AH01B, AH01S, AH02B, AH02S, AH04B and AH04S.

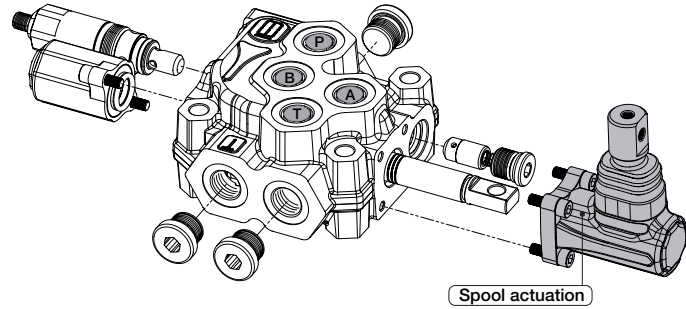

CODE	DESCRIPTION	CONFIGURATION	SYMBOL
AM01	Control lever		
AM02	Control lever rotated 180°		
AM05	Control tang spool end		
AM20	Control lever FLOAT - only with spool S05 - only with monoblock with RIGHT INLET		

WORK SECTION

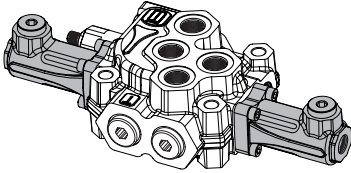
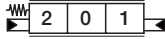
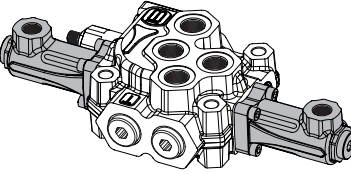
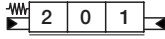
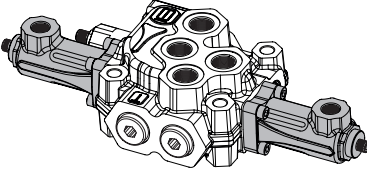
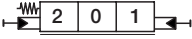
CODE	DESCRIPTION	CONFIGURATION	SYMBOL
AH01B	Hydraulic actuation with side ports (G 1/4)		
AH01S	Hydraulic actuation with side ports (SAE 6)		
AH02B	Hydraulic actuation with upper ports (G 1/4)		
AH02S	Hydraulic actuation with upper ports (SAE 6)		
AH04B	Hydraulic actuation with stroke limiter ports (G 1/4)		
AH04S	Hydraulic actuation with stroke limiter ports (SAE 6)		

SPRING CHARACTERISTIC CURVES HYDRAULIC ACTUATION

The graph shows the spool stroke as a function of the pressure operating.

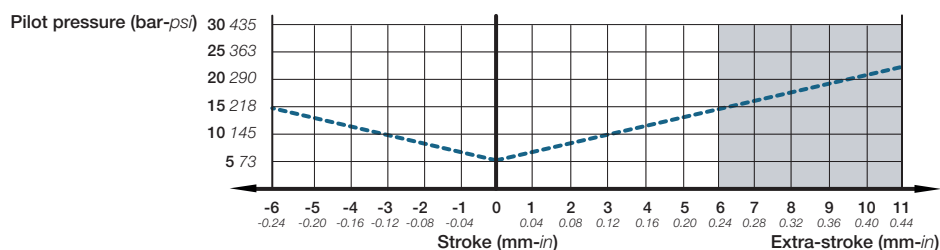
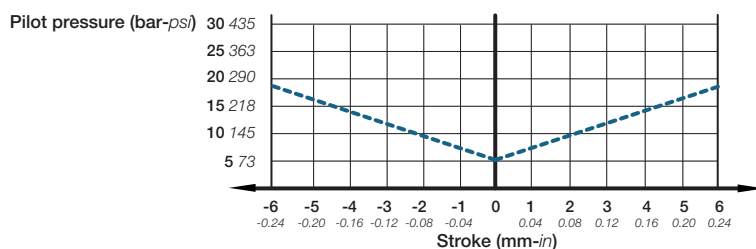

WORK SECTION

DIRECT ELECTRIC CONTROL - PUSH PUSH ACTUATION

The electric control for the ECM08B is equipped with two push-push magnets operating the spool. The Push-Push actuation is suitable for all the mobile applications and, in particular, for agriculture machines and gardening machines. This type of actuation is also recommended for earth moving and lifting machinery applications and, in particular, truck mounted crane, forestry cranes and aerial platform stabilizers. It enables the use of remote-control systems. The direct electric control needs a SE type special spool.

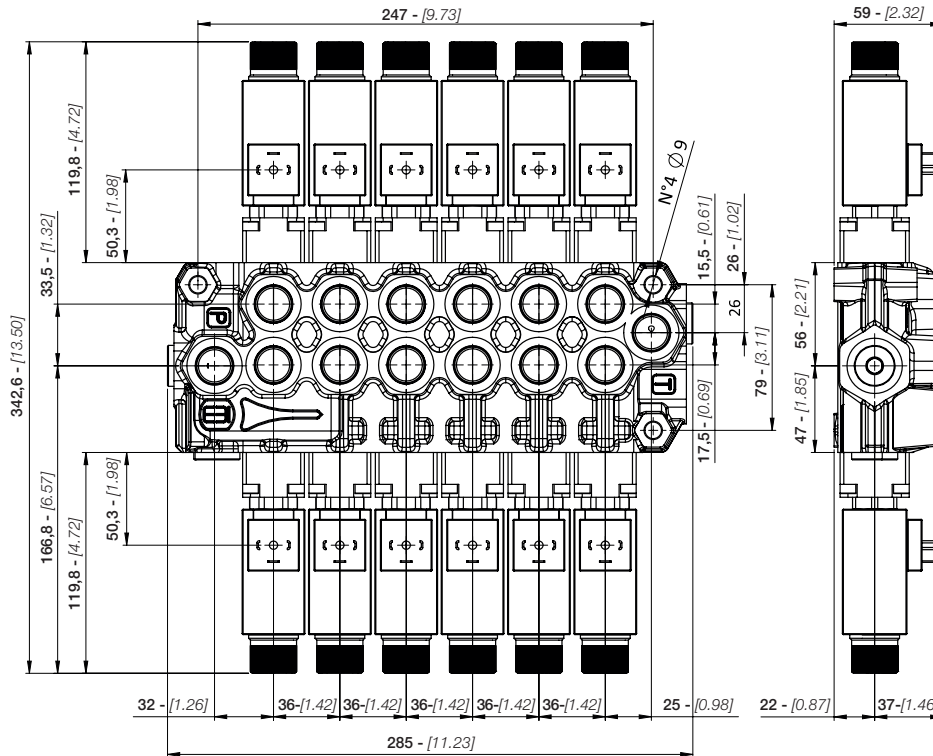

CODE	DESCRIPTION	SYMBOL
AR12	PUSH-PUSH 12 vdc	
AR13	PUSH-PUSH 24 vdc	

TECHNICAL SPECIFICATIONS		
Rated voltage	12 VDC	24 VDC
Rated current	3.75 A	1.88 A
Rated power	45 W	
Permitted working voltage	±10% nominal	
Max ambient temperature	40°C	
Max oil temperature	80°C	
Operation time	S1 100%	
Protection degree	IP65	
Insulation degree	H	
Standard connector	DIN 43650	
Spool stroke	3 + 3 mm	



Note:

Leave out the spool return action code when choosing Direct Electric Control push-push actuation AR12 or AR13.

WORK SECTION

OPERATING CURVE

Data detected after amperage decrease equal to 30% of the rated value.

Conditions occurring to coil at stabilization temperature and absorbed voltage decrease equal to 20% of the rated value.

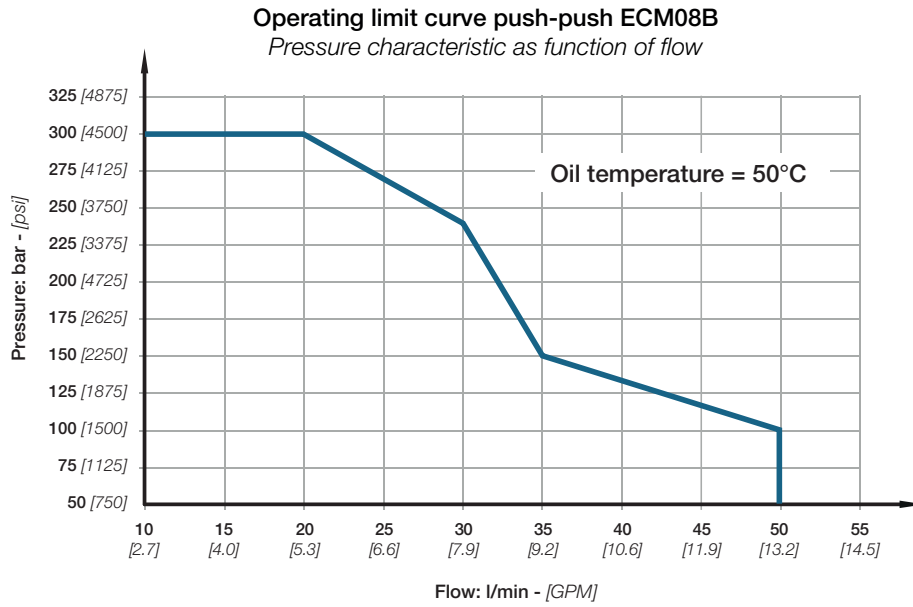

WORK SECTION

JOYSTICK CONTROL ACTUATION

The Joystick option is made to control 2 spools at the same time with one hand. The way it can manage the flow is based on the fulcrum position so the code.

In the following table you can refer lever actuation against flow on valve ports (A/B).

Actuation code for spool without fulcrum is always **AJ00**

Note: Lever for joystick control (M10) has to be ordered separately.

CODE	DESCRIPTION	FULCRUM POSITIONS	DRAWING	ACTUATIONS
AJ1L	Joystick control LEFT SIDE INLET Fulcrum on 1 st section	First section Second section AJ00		
AJ2L	Joystick control LEFT SIDE INLET Fulcrum on 2 nd section	Second section First section AJ00		
AJ1R	Joystick control RIGHT SIDE INLET Fulcrum on 1 st section	First section Second section AJ00		
AJ2R	Joystick control RIGHT SIDE INLET Fulcrum on 2 nd section	Second section First section AJ00		

WORK SECTION

product				1	2	3			4			5		6		7		8																
E	C	M	0	8	B	R	N	1	M	1	A	2	B	V	0	3	1	5	0	S	0	1	N	A	M	0	1	R	M	0	1	M	X	1

SPOOL RETURN ACTION

Spool return action for mechanical actuation have three different spring types:

- **M** (medium spring)
- **S** (soft spring)
- **H** (heavy spring)

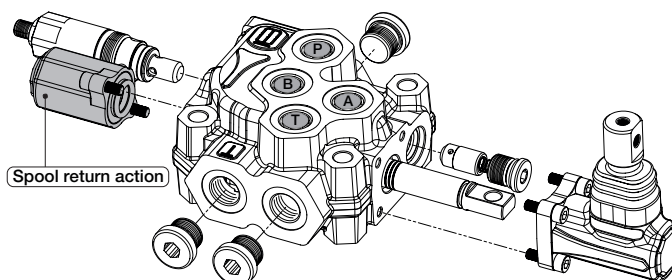

SPRING	F1 PRELOADING (N)	F2 END STROKE (N)
M (MEDIUM)	100	120
S (SOFT)	80	100
H (HEAVY)	130	170

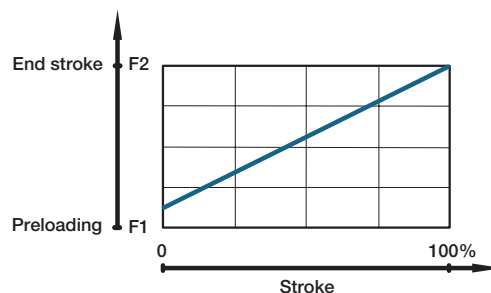

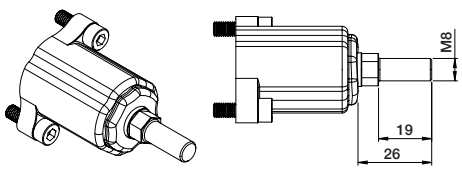
CODE	DESCRIPTION	SYMBOL
RM01M	3 position spring centered spool (MEDIUM spring)	
RM01S	3 position spring centered spool (SOFT spring)	
RM01H	3 position spring centered spool (HEAVY spring)	
RM02M	Dual command 	
RM03M	3 position spring centered spool with stroke limiter	
RM04M	Detent in position 1/2	
RM05M	Detent in position 1	
RM06M	Detent in position 2	

CODE	DESCRIPTION	SYMBOL
RM11M	Detent in 4 th position <i>- only with spool S05</i>	
RM12	Detent in position 1/0/2 without spring	
RM13M	Detent in 1/0/2/4 th position <i>- only with spool S05</i>	
RR01	Proportional pneumatic control (connections G 1/8)	
RR03	Proportional pneumatic control (connections NPTF 1/8-27)	

SPRING CHARACTERISTIC CURVE PNEUMATIC CONTROL

The diagram shows the spool stroke as a function of the pneumatic pressure operating.

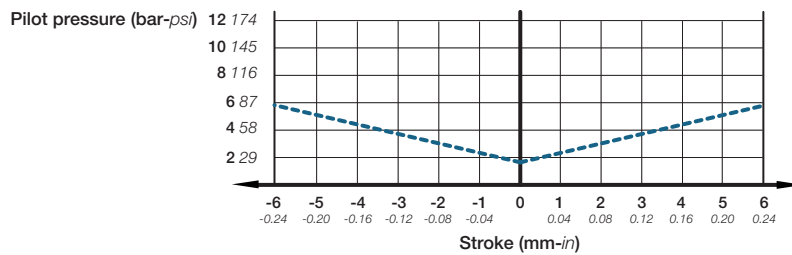

OPTION

PAINTING

On request all ECM08B monoblock control valves by EBI can be delivered painted (RAL 9005 black primer).

ORDER EXAMPLE OF ECM08B/1 PAINTED:

E	C	M	0	8	B	R	N	1	M	1	A	2	B	V	0	3	1	5	0	S	0	1	N	A	M	0	1	R	M	0	1	M	X	1
---	---	---	---	---	---	---	---	---	---	---	---	---	---	---	---	---	---	---	---	---	---	---	---	---	---	---	---	---	---	---	---	---	---	---

X1 Painted color black

CODE	DESCRIPTION
X1	ECM08A with 1 work section painted
X2	ECM08A with 8 work sections painted
X3	ECM08A with 9 work sections painted
X4	ECM08A with 4 work sections painted
X5	ECM08A with 5 work sections painted
X6	ECM08A with 6 work sections painted
X7	ECM08A with 7 work sections painted

ACCESSORIES

LEVER ROD FOR MANUAL OPERATION

The following table lists the lever available for the ECM08B control Valve.

CODE	DESCRIPTION	LENGHT	DRAWING	ORDER CODE
W08B	Lever rod for mechanical actuation	150 mm		A01170010
W08C		210 mm		A01170008



Note:

The lever rod must be ordered separately.

SPARE PARTS LIST

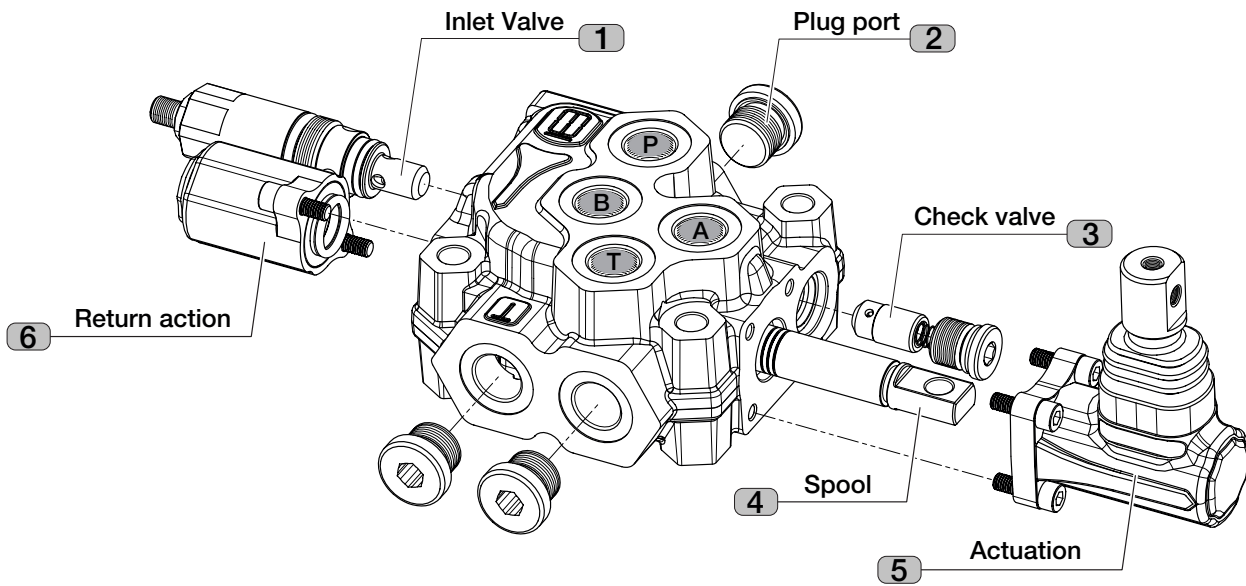

Note:

This example represents a ECM08B with manual actuation, main relief valve and body with BSP arrangement. All arrangement monoblock bodies are equipped with one check valve. All ECM08B can be easily trasformed from simple T port to HPCO configuration just by installing a conic plug G 1/4.

REFERENCE	CATALOGUE CODE	ORDER CODE	DESCRIPTION	NOTE
1	V02	VA030005	Relief valve plugged	RANGE available: A) 50 - 110 bar B) 111 - 160 bar C) 161 - 250 bar D) 251 - 350 bar For specific setting contact our sales department
	V03050	VA0105003	Direct acting pressure relief valve (50 bar)	
	V03100	VA0110003	Direct acting pressure relief valve (100 bar)	
	V03150	VA0115003	Direct acting pressure relief valve (150 bar)	
	V03200	VA0120003	Direct acting pressure relief valve (200 bar)	
	V03250	VA0125003	Direct acting pressure relief valve (250 bar)	
	V03300	VA0130003	Direct acting pressure relief valve (300 bar)	
	V03350	VA0135003	Direct acting pressure relief valve (350 bar)	
2		C03010004	Port plug G 3/8	
		C03010003	Port plug SAE8	
3		A01020005	Check valve	
4	S01N	A01150042	3 positions double acting	Only for monoblock with LEFT inlet (L)
	S02N	A01150045	3 positions double acting A/B to tank	
	S03N	A01150102	3 positions single acting on A	
	S04N	A01150103	3 positions single acting on B	
	S05N	A01150122	4 positions double acting with FLOAT in 4 th position	
	S11N	A01150123	3 positions double acting A to tank - B blocked.	
	S12N	A01150124	3 positions double acting A blocked - B to tank.	

REFERENCE	CATALOGUE CODE	ORDER CODE	DESCRIPTION	NOTE
4	S01N	A01150027	3 positions double acting	Only for monoblock with RIGHT inlet (R)
	S02N	A01150035	3 positions double acting A/B to tank	
	S03N	A01150101	3 positions single acting on A	
	S04N	A01150088	3 positions single acting on B	
	S05N	A01150039	4 positions double acting with FLOAT in 4 th position	
	S11N	A01150125	3 positions double acting A to tank - B blocked.	
	S12N	A01150126	3 positions double acting A blocked - B to tank.	
5	AM01	A01030005	Control lever	Manual actuation
	AM02	A01030005	Control lever rotated 180°	
	AM05	A01030006	Control tang spool end	
	AM20	A01030011	Control lever - FLOAT	
	AH01B	A01040056	Hydraulic actuation - SIDE ports G 1/4	Hydraulic actuation
	AH01S	A01040057	Hydraulic actuation - SIDE ports SAE6	
	AH02B	A01040053	Hydraulic actuation - UPPER ports G 1/4	
	AH02S	A01040058	Hydraulic actuation - UPPER ports SAE6	
	AH04B	A01040059	Hydraulic actuation - stroke limiter ports G 1/4	
	AH04S	A01040060	Hydraulic actuation - stroke limiter ports SAE6	
	AJ1L	A01110002	Joystick control - Fulcrum on 1 st section	Only for LEFT inlet (L)
	AJ2L	A01110004	Joystick control - Fulcrum on 2 nd section	
	AJ1R	A01110004	Joystick control - Fulcrum on 1 st section	Only for RIGHT inlet (R)
AJ2R	A01110002	Joystick control - Fulcrum on 2 nd section		
6	RM01M	A01120013	3 position spring centered spool (MEDIUM spring)	
	RM01S	A01120027	3 position spring centered spool (SOFT spring)	
	RM01H	A01120018	3 position spring centered spool (HIGH spring)	
	RM02M	A01120019	Dual command	
	RM03M	A01120026	3 position spring centered spool (MEDIUM spring) with stroke limiter	
	RM04M	A01130018	Detent in position 1/2	
	RM05M	A01130019	Detent in position 1	
	RM06M	A01130020	Detent in position 2	
	RM11M	A01130029	Detent in 4 th position (FLOAT)	
	RM12	A01130008	Detent in position 1/0/2 without spring	
	RM13M	A01130026	Detent in position 1/0/2/FLOAT (MEDIUM spring)	
	RR01	A01050008	Proportional pneumatic control G 1/8	Pneumatic Actuation
	RR03	A01050009	Proportional pneumatic control NPTS 1/8 - 27	



Note:

All ECM08B can be easily trasformed from simple T port to HPCO configuration just by installing a conic plug G 1/4. These examples represent monoblock body in configuration M2A2B.

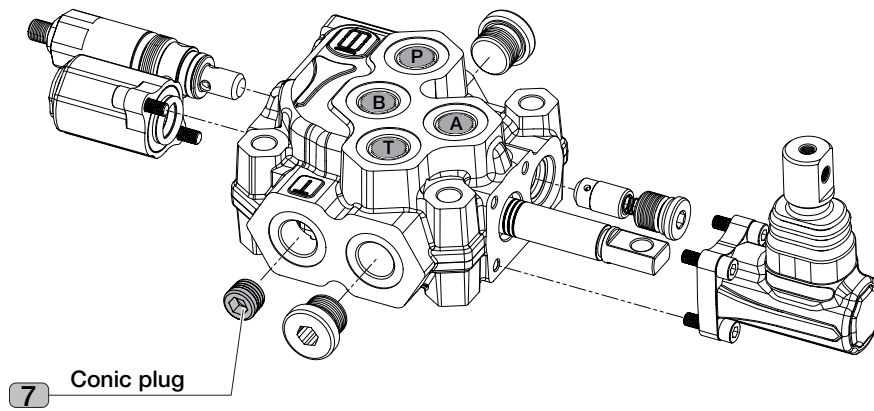

REFERENCE	CATALOGUE CODE	ORDER CODE	DESCRIPTION	NOTE
7		C03000002	Conic plug G 1/4	

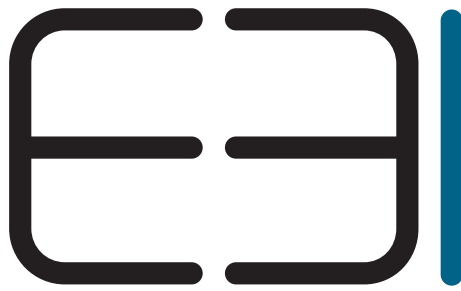

engineering beyond imagination

EBI MOTION CONTROLS S.r.l

Via Andrea Costa 11/2 40057
Cadriano Fraz. di Granarolo dell'Emilia (BO)
TEL. +39 051.0188.800
FAX 051.701.093

info@ebimc.com
www.ebimc.com