



ECM08B

Monoblock directional control valve

DT.ECM08B.02

FUNCTIONS AND BENEFITS

- Compact directional valve with low pressure losses.
- Interchangeable spools.
- Availability of manual, pneumatic and hydraulic actuators.

TECHNICAL DATA

Number of sections	1-7
Parallel spool stroke (mm-in)	5.5 [0.22]
Float spool extra stroke (mm-in)	4.5 [0.18]
Spool pitch (mm-in)	36 [1.42]
Spool diameter (mm-in)	14 [0.55]
Nominal flow (l/min-GPM)	50 [12]
Operating pressure (bar-psi)	350 [5000]

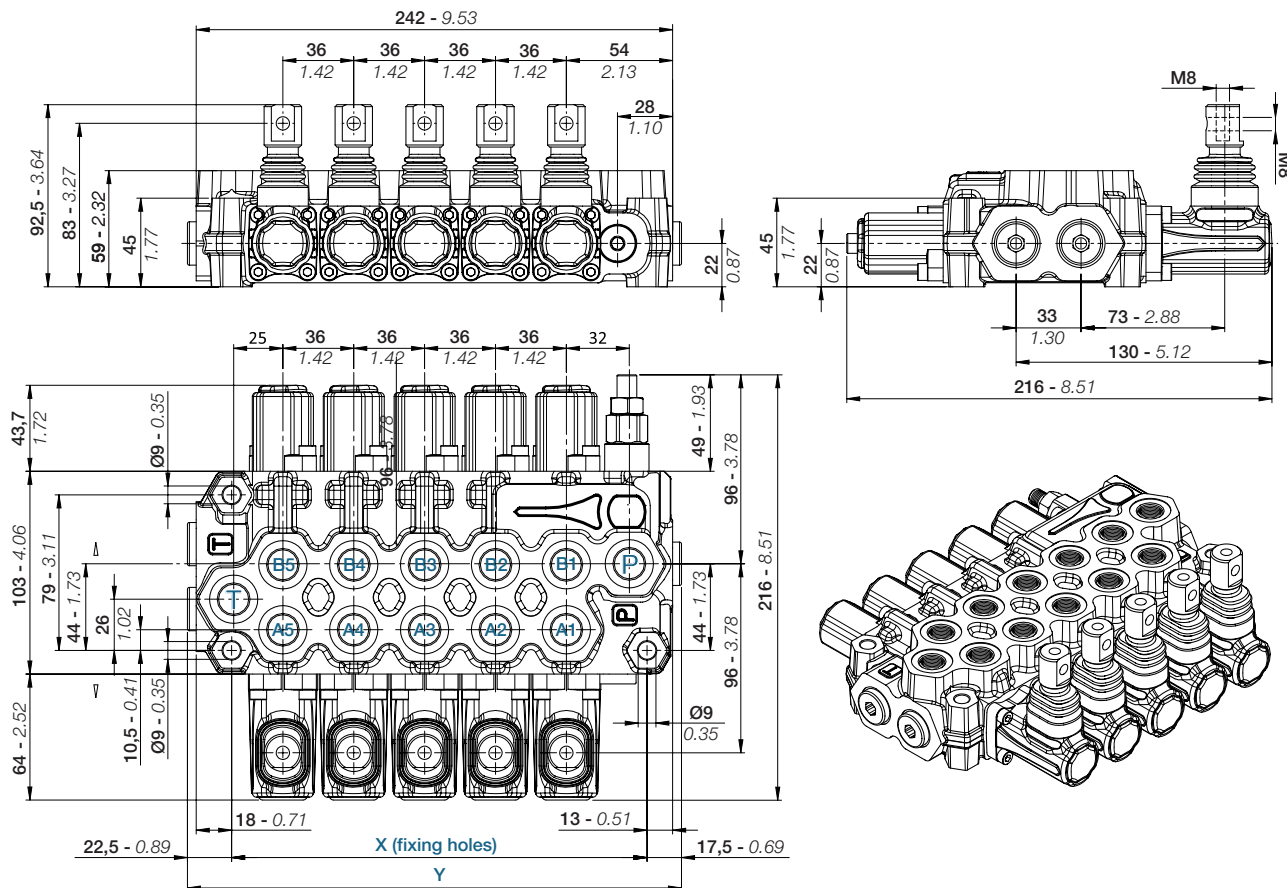

DIMENSIONS

The dimensional drawing represents a ECM08B/5 with manual actuation and SAE connections.

TYPE	BSP (ISO 1179-1)	UN-UNF (ISO 11926-1)
INLET - P	G 3/8	3/4" - 16 UNF
PORTS - A/B	G 3/8	3/4" - 16 UNF
Hydraulic pilot	G 1/4	9/16" - 18 UNF
Pneumatic pilot	G 1/8	NPTF 1/8-27
OUTLET - T/T1	G 3/8	3/4" - 16 UNF

TYPE	X (mm / in)	Y (mm / in)
ECM08B/1	67 - [2.64]	107 - [4.22]
ECM08B/2	103 - [4.06]	143 - [5.63]
ECM08B/3	139 - [5.48]	179 - [7.05]
ECM08B/4	175 - [6.90]	215 - [8.47]
ECM08B/5	211 - [8.31]	251 - [9.89]
ECM08B/6	247 - [9.73]	287 - [11.30]
ECM08B/7	283 - [11.15]	323 - [12.73]



EBI MOTION CONTROLS S.r.l
 Via Andrea Costa 11/2, 40057
 Cadriano, Fraz. di Granarolo
 dell'Emilia (BO)
 Tel. +39 051.0188.800
 Fax 051.701.093
www.ebimc.com
info@ebimc.com

ECM08B

Monoblock directional control valve



TYPICAL CURVES

All performances are obtained using mineral based hydraulic oil 46 cSt viscosity at 40°C (ISO VG46 viscosity class). All ECM08B go through functional testing at these conditions before shipment.

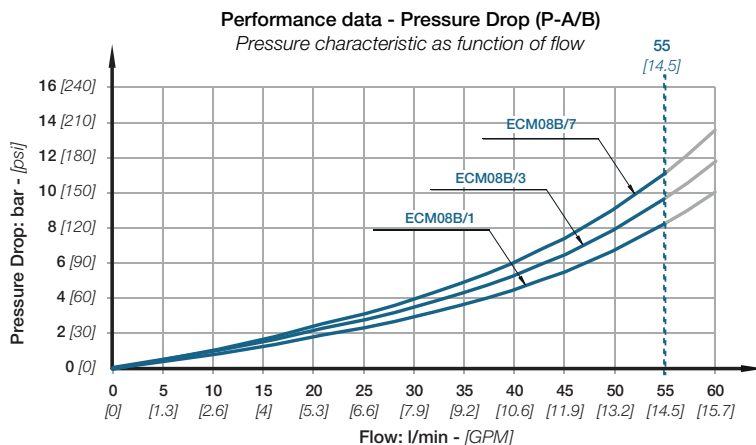
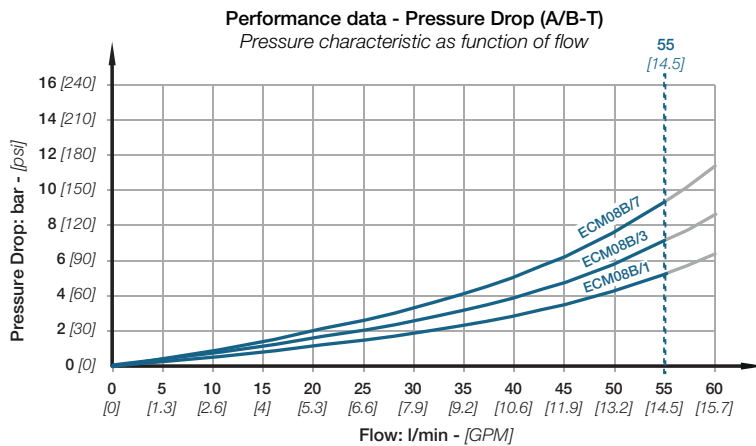
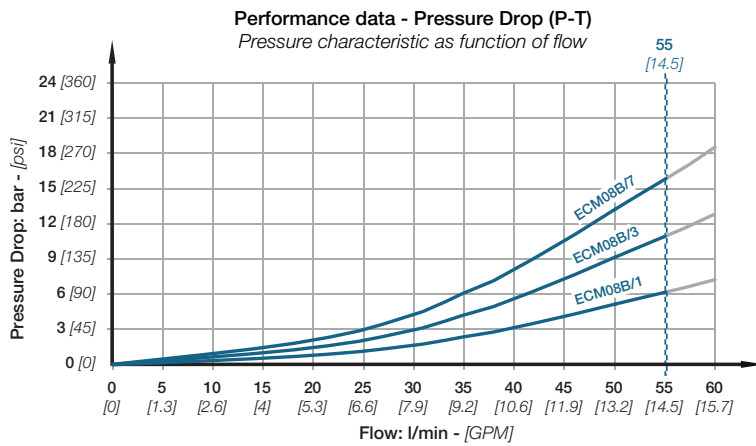

APPLICATIONS

EBI motion controls provides a broad choice of monoblock directional control valves expertly developed and tested to meet different market sectors' needs.

ECM08B are suited for specialized applications for a variety of mobile equipment such as:



OPTIONAL FEATURES

- All ECM08B can be easily transformed from simple T port to HPCO configuration just by installing a conic plug G 1/4.
- On request all ECM08B monoblock control valves by EBI can be delivered painted (RAL 9005 black primer).
- To improve performance and controllability, a full range of hydraulic remote controls (joysticks and foot pedals) is available (see ESJ01A, ESJ02A, ESP02B, ect.)