



Monoblock and stackable diverters

EDM-EDS

Rev. 03 • October, 2023

TECHNICAL CATALOGUE



.....
Diverters



HISTORY OF REVISIONS

DATE	PAGE	CHANGED	REV.
December, 2018	-	First edition	00
November, 2019	20-21-25-26	Updated assembly kits and RD04 added choice	01
May, 2021	14-15	Updated typical curves	02
October, 2023	22 - 24	Body with check valves added. Pneumatic actuation added	03

ABOUT THE MANUAL

This manual contains the technical instructions for the diverters range.
All information given in this manual is current and valid according to the information available at the time of publication.
The data specified above only serve to describe the product. EBI Motion controls reserves to modify or revise the instructions without prior notice.

EBI Motion controls is not responsible for any damage caused by an incorrect use of the product.
Please visit www.ebimc.com for the most recent version of this manual.

CONTENTS

4 INTRODUCTION

5 GENERAL INFORMATION
HYDRAULIC OPERATING PRINCIPLE

6 GENERAL INSTRUCTIONS

8 QUICK REFERENCE GUIDE
STANDARD THREADS

9 PORT DETAILS

10 DIMENSIONS - EDM08A

11 DIMENSIONS - EDS08A

12 DIMENSIONS - EDM10A

13 DIMENSIONS - EDS10A

14 TYPICAL CURVES - EDM08A/EDS08A

15 TYPICAL CURVES - EDM10A/EDS10A

16 TECHNICAL DATA
HYDRAULIC STANDARD SPECIFICATIONS
MATERIAL STANDARD SPECIFICATIONS
SEALS

HYDRAULIC FLUID

18 APPLICATION AND SAFETY GUIDELINES
STORAGE OF NEW PRODUCT
SAFETY GUIDELINES

19 ORDERING CODES - MONOBLOCK DIVERTER

20 ORDERING CODES - STACKABLE DIVERTER
ASSEMBLY SECTION
BODY CLASSIFICATION
ASSEMBLY SPOOL
SOLENOIS ACTUATION TYPE
RETURN ACTION TYPE

26 COMPATIBILITY TABLE

27 INSTALLATION AND MAINTENANCE



INTRODUCTION

DIVERTERS

EBI motion controls diverter valves (monoblock and stackable) are used to pilot remote of directional control valves, auxiliary valves, variable displacement pumps and motors, frictions and hydraulic brakes, all with high accuracy, safety and optimal performance. EBI motion controls diverters are maintenance free and have a long life cycle and are suited for specialized applications for a variety of mobile equipment such as:

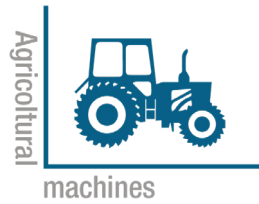
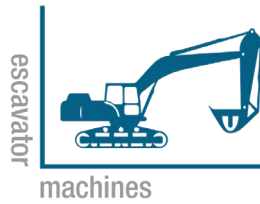
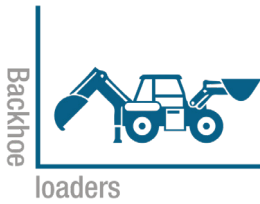

EDM

MONOBLOCK DIVERTERS



Usable as stand-alone.
Directional spool valve with direct solenoid control.
Coils with different connectors and voltage are available.
Compact design and easy mounting.
Integrated threaded ports.

EDS

STACKABLE DIVERTERS

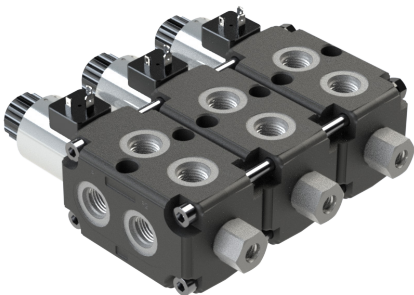

Usable as multiple stackable units.
Directional spool valve with direct solenoid control.
Coils with different connectors and voltage are available.
Compact design and easy mounting.
Integrated threaded ports.

GENERAL INFORMATION

HYDRAULIC OPERATING PRINCIPLE

EBI diverter valves are suitable to intercept and divert the flow on hydraulic system, wherever movement sequence or control selection of different actuators is needed.

A valve basically consists of a housing (1), a control spool (2), a return spring (3) and a solenoid (4).

It is designed to connect two inlet lines P1 – P2 (normally a set of hoses) and divert them to either the outlet ports (C1 – C4) with spool in position “0”, when the solenoid is de-energized, or to the outlet ports (C2 – C3) with spool in position “1”, when the solenoid is energized.

With the coil de-energized, the return spring pushes back the spool and holds it in position “0”.

The coil is fastened to the tube by the ring nut. The manual override allows to shift the spool also in case of voltage shortage. An external drain, to be connected to tank, ensures shifting operations also at higher working pressure.

EXAMPLE OF CONNECTION

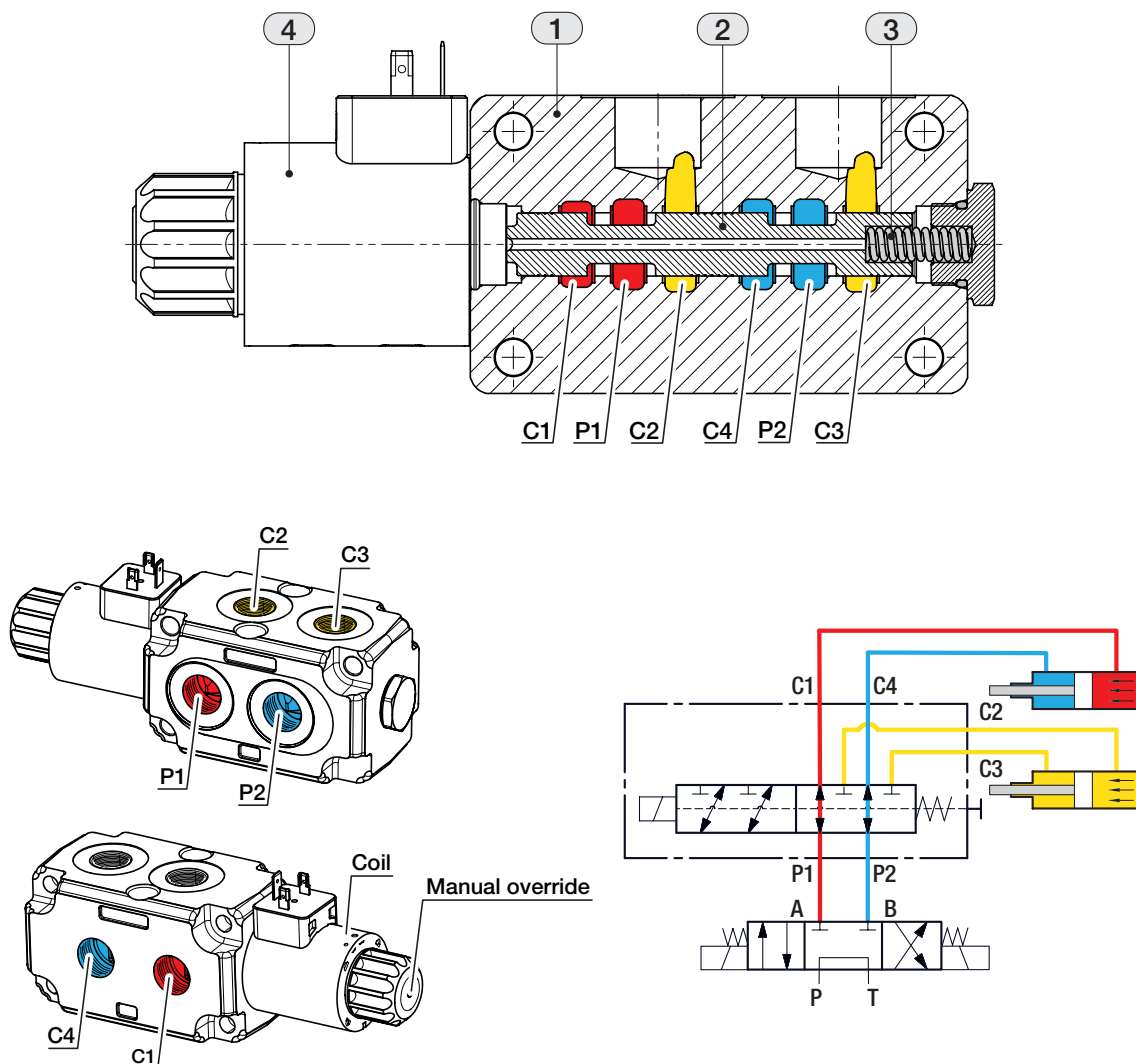

GENERAL INSTRUCTIONS

INTENDED USE

EDM-EDS diverters are designed for industrial use.

WARRANTY

Check the package and the product for transport damage when receiving goods. The package is not meant for long term storage; protect the product appropriately.

Do not dismantle the product. The warranty is void if the product has been disassembled.

The manufacturer is not responsible for damages resulting from misinterpreted, noncompliance, incorrect, or improper use of the product that goes against the instructions given in this document.

GENERAL SAFETY INSTRUCTIONS

The following instructions apply to all procedures associated with the product. Read these instructions carefully and follow them closely.

- Use necessary personal protective equipment when working with the product.
- Support the product properly; make sure the product cannot fall over or turn around by accident.
- Use only appropriate equipment and attachments for lifting and transferring the product.
- Always use the lifting equipment properly and check the load-bearing capacity.
- Prevent unintended use of the product during installation and maintenance procedures.

WARNING SYMBOL

The following symbols can be used in this manual:



Note:
Useful information



Danger:
Danger of death or injury



Attention:
May cause damage to the product

PRODUCT IDENTIFICATION

The product identification data can be found on the identification plate attached to the EBI product.

SERIAL NUMBER

all manufacturing data and all sales data can be found with the serial number

PART NUMBER CODE

It is a number univocally identifying the configuration and pressure setting of a valve

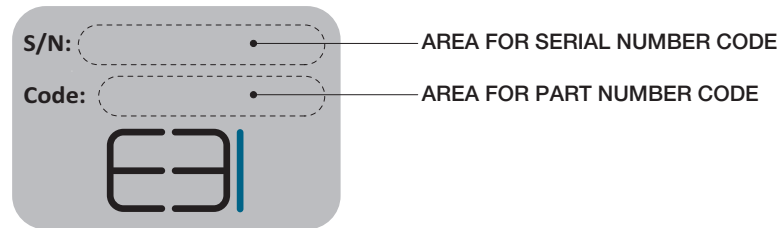

Note:

Serial number and part number code have 9 characters (letters and numbers).

UNITS OF MEASURE - CONVERSION FACTORS

LENGHT	FLOW RATE	MASS	FORCE WEIGHT	PRESSURE
1 mm = 0,0394 in	1 l = 0,2200 gal UK	1 kg = 2,205 lb	1 N = 0,1020 Kgf	1 bar = 100000 Pa
1 in = 25,4 mm	1 l = 0,2642 gal US	1 lb = 0,4536 kg	1 Kgf = 9,8067 N	1 bar = 14,5 psi
	1 gal UK = 4,546 l			1 Pa = 0,0001 bar
	1 gal UK = 1,2010 gal US			1 Pa = 0,00014 psi
	1 gal US = 3,785 l			1 psi = 0,0689 bar
	1 gal US = 0,8327 gal UK			1 psi = 6890 Pa

QUICK REFERENCE GUIDE

TYPE	EDM08A	EDM10A	EDS08A	EDS10A
Number of ways	6-7*	6-7*	6-7*	6-7*
Number of sections	1	1	2-3-4	2-3-4
Nominal flow (l/min) - [GPM]	50 [14]	100 [28]	50 [14]	100 [28]
Internal leakage A(B) → T (cm ³ /min) Δp = 100 bar / T = 40° C	min. 10 [0.61] - max. 20 [1.22]			
Operating pressure (bar) [psi]	250 [3625]	250 [3625]	250 [3625]	250 [3625]
Operating pressure by using external drain (bar) [psi]	310 [4500]	310 [4500]	310 [4500]	310 [4500]
Diverter valve stroke (mm) [in]	3,2 [0.13]	3,2 [0.13]	3,2 [0.13]	3,2 [0.13]
SPOOL ACTUATION	EDM08A	EDM10A	EDS08A	EDS10A
Solenoid 12 VDC	•	•	•	•
Solenoid 24 VDC	•	•	•	•
SPOOL ACTUATION	EDM08A	EDM10A	EDS08A	EDS10A
Without drain	•	•	•	•
With drain	•	•	•	•

(*) = every diverter valve is available on 7 ways with a special spool and a special plug.

STANDARD THREADS

TYPE OF PORT	TYPE OF THREAD	EDM08A	EDM10A	EDS08A	EDS10A
inlet port (P1 - P2)	BSP - ISO 1179-1	G 3/8	G 1/2	G 3/8	G 1/2
	UN/UNF ISO 11926-1	3/4-16 UNF (SAE8)	7/8-14 UNF (SAE10)	3/4-16 UNF (SAE8)	7/8-14 UNF (SAE10)
	BSP - ISO 228 d	G 3/8 JIS B 2351	G 1/2 JIS B 2351	G 3/8 JIS B 2351	G 1/2 JIS B 2351
service port (C1 - C4)	BSP - ISO 1179-1	G 3/8	G 1/2	G 3/8	G 1/2
	UN/UNF ISO 11926-1	3/4-16 UNF (SAE8)	7/8-14 UNF (SAE10)	3/4-16 UNF (SAE8)	7/8-14 UNF (SAE10)
	BSP - ISO 228 d	G 3/8 JIS B 2351	G 1/2 JIS B 2351	G 3/8 JIS B 2351	G 1/2 JIS B 2351
service port (C2 - C3)	BSP - ISO 1179-1	G 3/8	G 1/2	G 3/8	G 1/2
	UN/UNF ISO 11926-1	3/4-16 UNF (SAE8)	7/8-14 UNF (SAE10)	3/4-16 UNF (SAE8)	7/8-14 UNF (SAE10)
	BSP - ISO 228 d	G 3/8 JIS B 2351	G 1/2 JIS B 2351	G 3/8 JIS B 2351	G 1/2 JIS B 2351
drain port (D)	BSP - ISO 1179-1	G 1/4			
	UN/UNF ISO 11926-1	7/16-20 UN (SAE4)			

PORT DETAILS

The connection port size is indicated by an ordering code common for all EBI products. Following tables show all available connections.

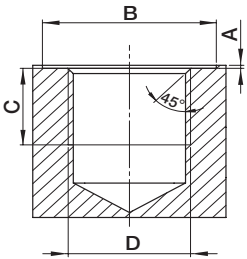
BSP THREADS ISO 1179-1	D	C		B		A		CODE
	UNI-ISO 228	mm	inc	mm	inc	mm	inc	
	G 1/4	13	0.51	19	0.75	1	0.094	1B
	G 3/8	13	0.51	25	0.98	1	0.04	2B
	G 1/2	15	0.59	29	1.14	1.5	0.06	3B
	G 3/4	17	0.67	36	1.42	1.5	0.06	4B
	G 1	19	0.75	45	1.77	2	0.08	5B

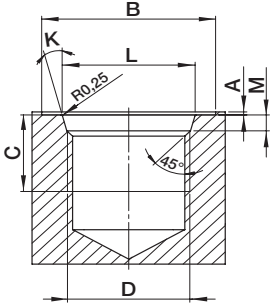
UN/UNF THREADS ISO 11926-1	D	C		B		L		M		K	A		CODE
	ASA-B1-1	mm	inc	mm	inc	mm	inc	mm	inc		mm	inc	
	7/16-20 UNF (SAE4)	12	0.47	19	0.75	12.5	0.49	2.4	0.095	12°	1	0.04	0S
	9/16-18 UNF (SAE6)	13	0.51	26	1.02	15.6	0.61	2.5	0.098	12°	1	0.04	1S
	3/4-16 UNF (SAE8)	15	0.59	30	1.18	20.6	0.81	2.6	0.102	15°	1.5	0.06	2S
	7/8-14 UNF (SAE10)	17	0.67	34	1.34	23.9	0.94	2.6	0.102	15°	1.5	0.06	3S
	1"1/16-12 UNF (SAE12)	20	0.79	41	1.61	29.2	1.15	3.3	0.13	15°	1.5	0.06	4S
	1"5/16-12 UNF (SAE16)	20	0.79	50	1.97	35.5	1.40	3.3	0.13	15°	2	0.08	5S

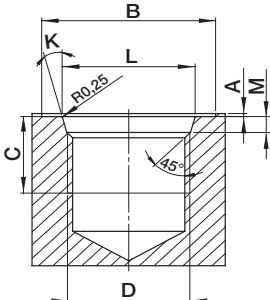
BSP THREADS ISO 228 d	D	C		B		L		M		K	A		CODE
	JIS B 2351	mm	inc	mm	inc	mm	inc	mm	inc		mm	inc	
	G 3/8	12	0.47	26	1.02	18.6	0.73	2.5	0.098	15°	1	0.04	2J
	G 1/2	16	0.63	34	1.34	22.6	0.89	2.5	0.098	15°	1.5	0.06	3J

DIMENSIONS - EDM08A

This drawing represents a EDM08A with DIN 43650 ISO 4400 Solenoid kit, internal drain circuit with BSP connections.

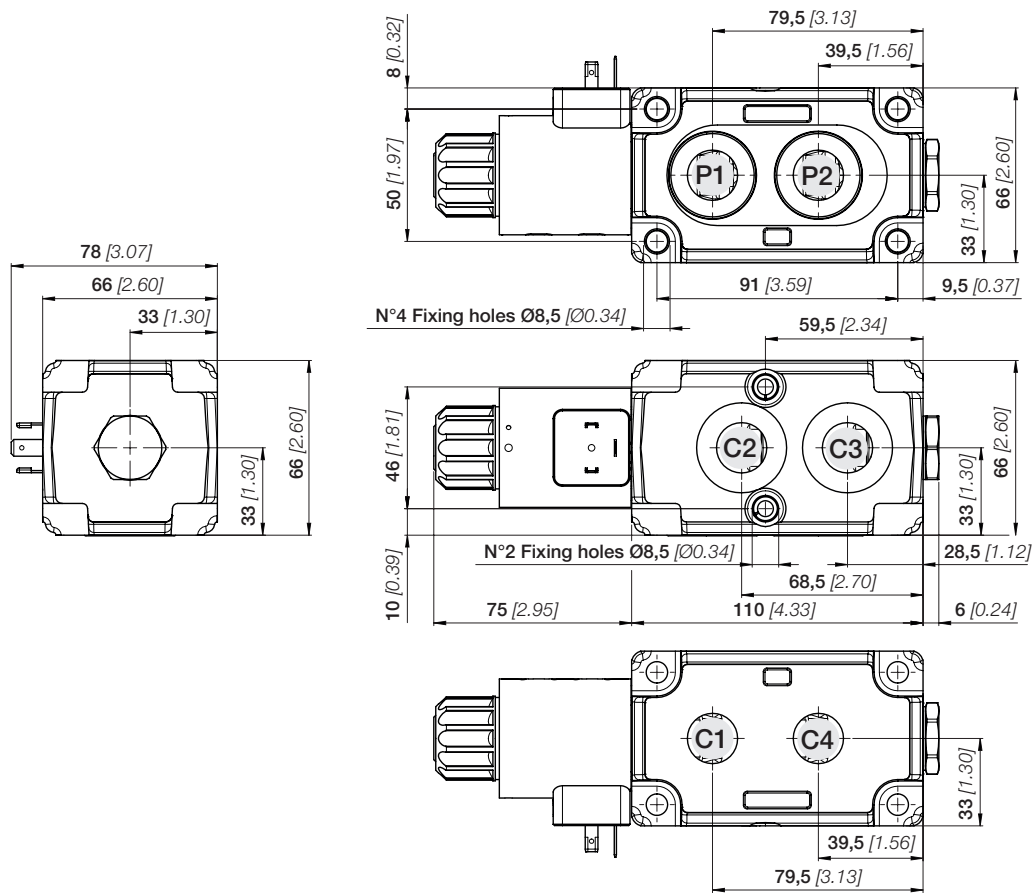

TECHNICAL SPECIFICATIONS

TYPE	DIMENSION mm - [in]	WEIGHT kg - [lb]
EDM08A/1	66 - [2.60]	3,3 - [7,3]

HYDRAULIC SYMBOL

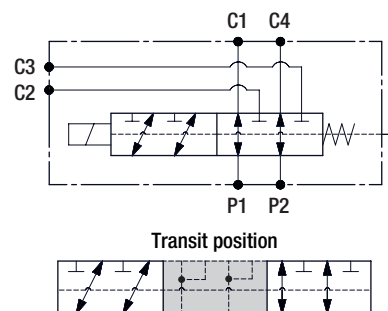

STANDARD CONNECTIONS

TYPE PORTS	BSP ISO 1179-1	UN-UNF ISO 11926-1	BSP ISO 228 d
P1 - P2	G 3/8	3/4-16 UNF (SAE8)	G 3/8 (JIS B 2351)
C1 - C4	G 3/8	3/4-16 UNF (SAE8)	G 3/8 (JIS B 2351)
C2 - C3	G 3/8	3/4-16 UNF (SAE8)	G 3/8 (JIS B 2351)

DIMENSIONS - EDS08A

This drawing represents a EDS08A with DIN 43650 ISO 4400 Solenoid kit, internal drain circuit with BSP connections.

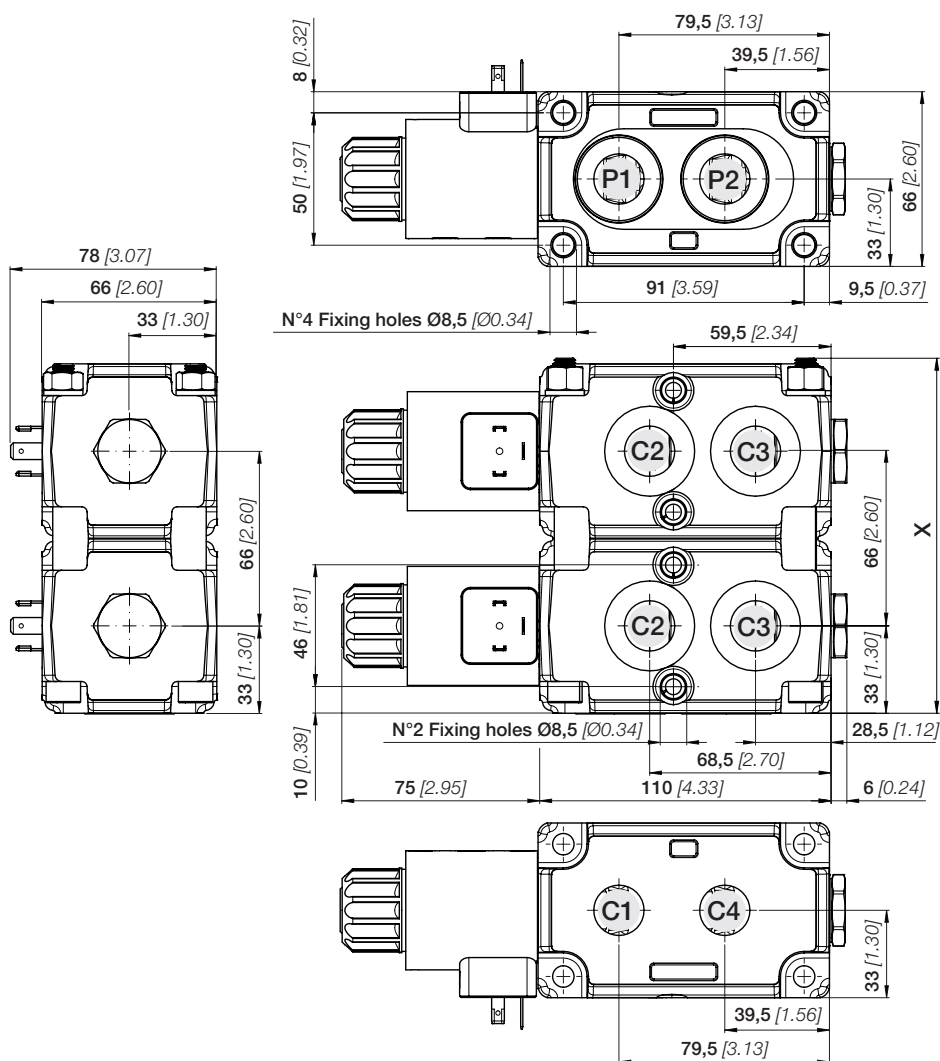

TECHNICAL SPECIFICATIONS

TYPE	DIMENSION (X) mm - [in]	WEIGHT kg - [lb]
EDS08A/2	136 - [5.36]	6,8 - [15]
EDS08A/3	202 - [7.96]	10,3 - [22.7]
EDS08A/4	268 - [10.56]	13,7 - [29.5]

STANDARD CONNECTIONS

TYPE PORTS	BSP ISO 1179-1	UN-UNF ISO 11926-1	BSP ISO 228 d
P1 - P2	G 3/8	3/4-16 UNF (SAE8)	G 3/8 (JIS B 2351)
C1 - C4	G 3/8	3/4-16 UNF (SAE8)	G 3/8 (JIS B 2351)
C2 - C3	G 3/8	3/4-16 UNF (SAE8)	G 3/8 (JIS B 2351)

HYDRAULIC SYMBOL

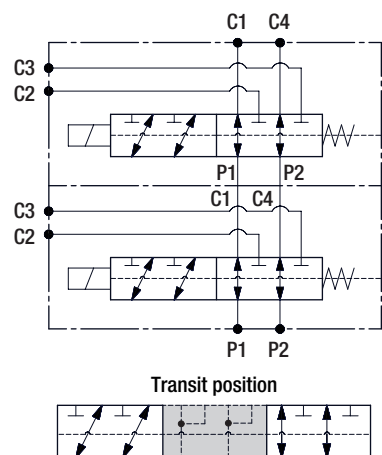

DIMENSIONS - EDM10A

This drawing represents a EDM10A with DIN 43650 ISO 4400 Solenoid kit, internal drain circuit with BSP connections.

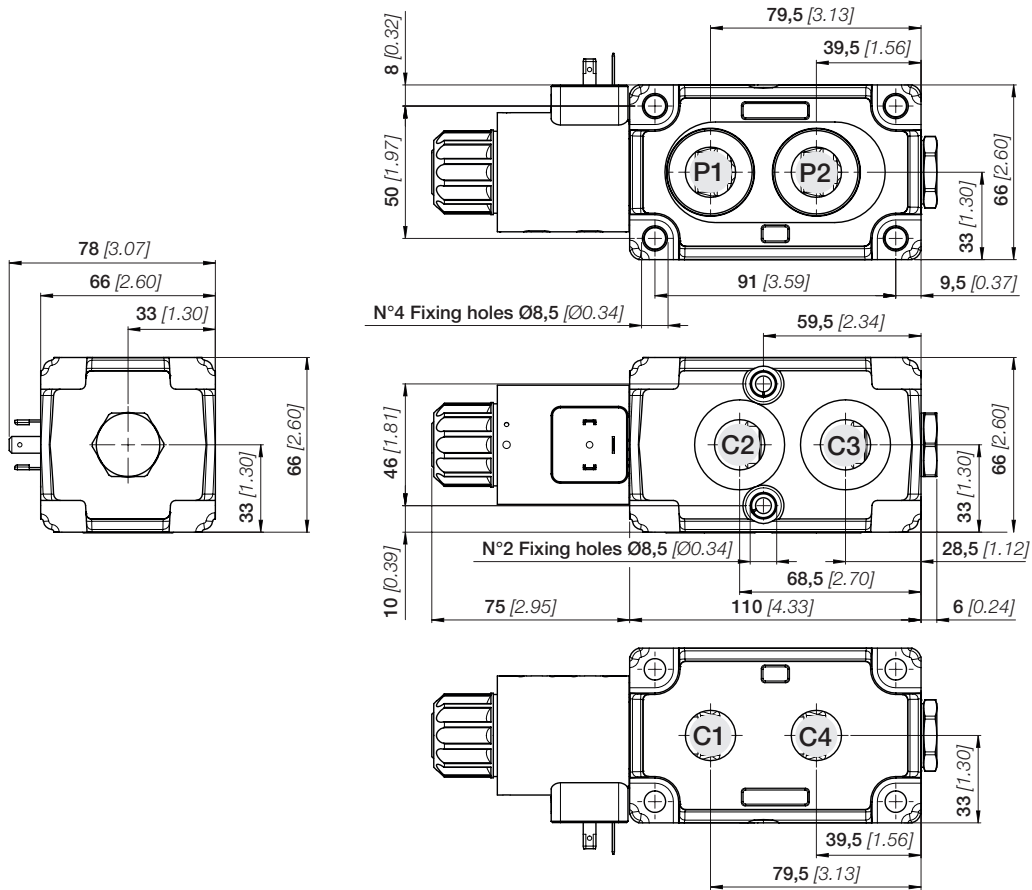

TECHNICAL SPECIFICATIONS

TYPE	DIMENSION mm - [in]	WEIGHT kg - [lb]
EDM10A/1	66 - [2.60]	3,3 - [7,3]

HYDRAULIC SYMBOL

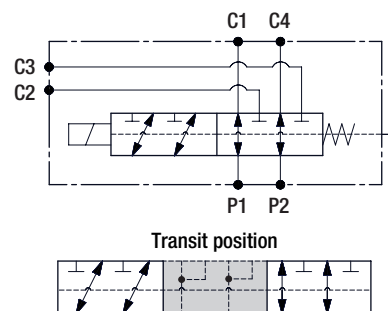

STANDARD CONNECTIONS

TYPE PORTS	BSP ISO 1179-1	UN-UNF ISO 11926-1	BSP ISO 228 d
P1 - P2	G 1/2	7/8-14UNF (SAE10)	G 1/2 (JIS B 2351)
C1 - C4	G 1/2	7/8-14UNF (SAE10)	G 1/2 (JIS B 2351)
C2 - C3	G 1/2	7/8-14UNF (SAE10)	G 1/2 (JIS B 2351)

DIMENSIONS - EDS10A

This drawing represents a EDS10A with DIN 43650 ISO 4400 Solenoid kit, internal drain circuit with BSP connections.

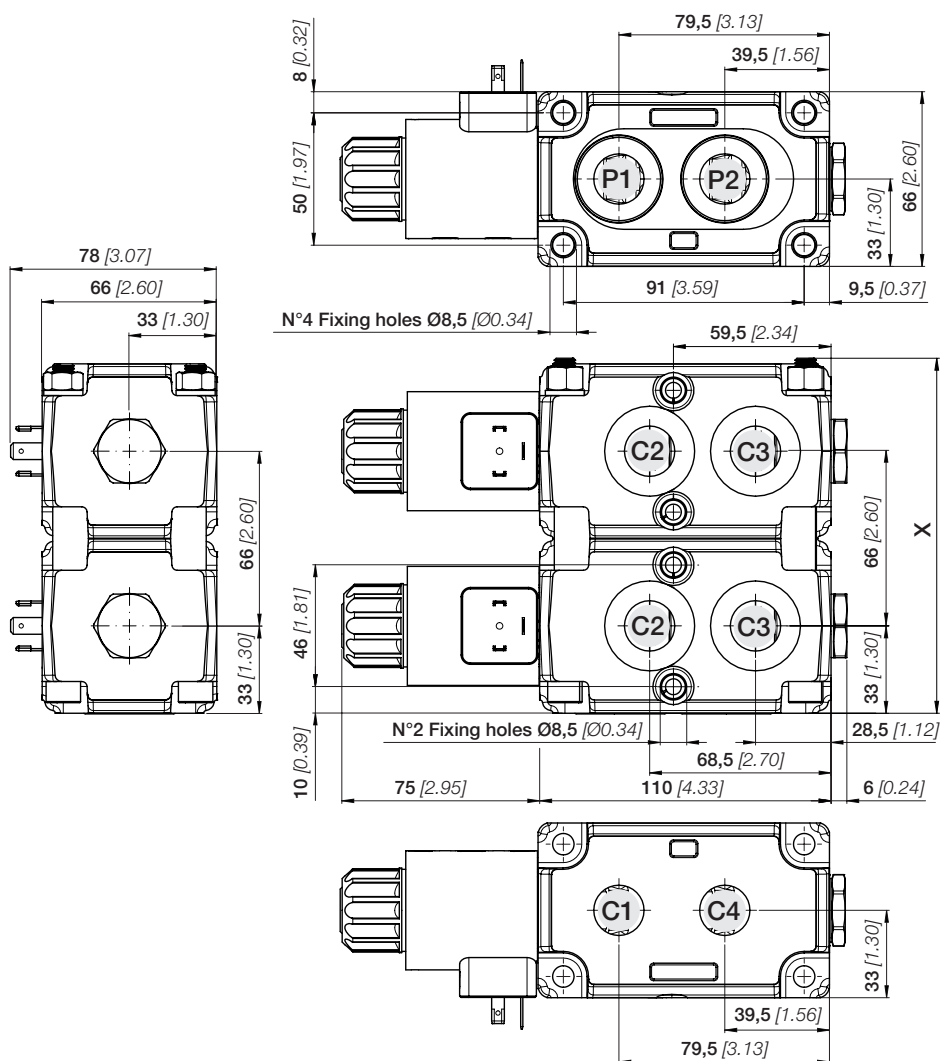

TECHNICAL SPECIFICATIONS

TYPE	DIMENSION (X) mm - [in]	WEIGHT kg - [lb]
EDS10A/2	136 - [5.36]	6,8 - [15]
EDS10A/3	202 - [7.96]	10,3 - [22.7]
EDS10A/4	268 - [10.56]	13,7 - [29.5]

HYDRAULIC SYMBOL

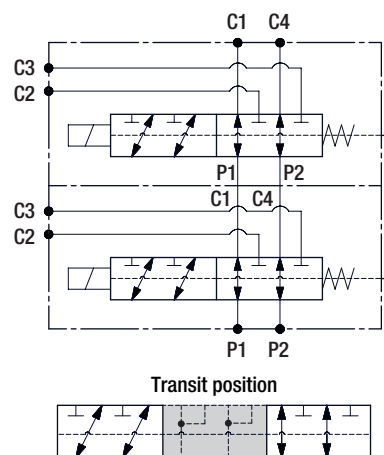

STANDARD CONNECTIONS

TYPE PORTS	BSP ISO 1179-1	UN-UNF ISO 11926-1	BSP ISO 228 d
P1 - P2	G 1/2	7/8-14UNF (SAE10)	G 1/2 (JIS B 2351)
C1 - C4	G 1/2	7/8-14UNF (SAE10)	G 1/2 (JIS B 2351)
C2 - C3	G 1/2	7/8-14UNF (SAE10)	G 1/2 (JIS B 2351)

TYPICAL CURVES - EDM08A/EDS08A

All information and diagrams in this manual refer to a mineral base oil ISO-VG46 at $40^\circ \pm 5^\circ\text{C}$ temperature (32 cSt kinematic viscosity).

PERFORMANCE DATA - Pressure characteristic as function of flow

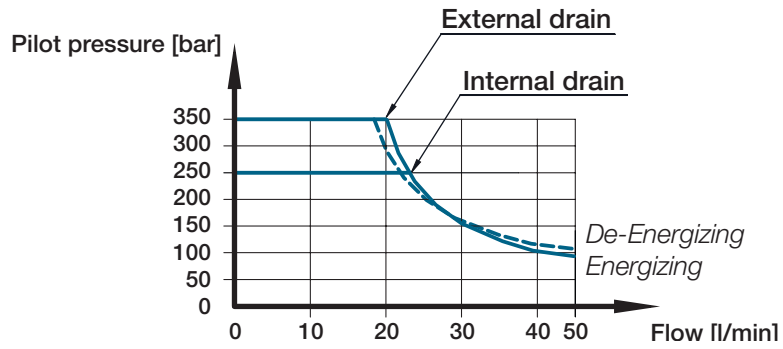

PRESSURE DROP

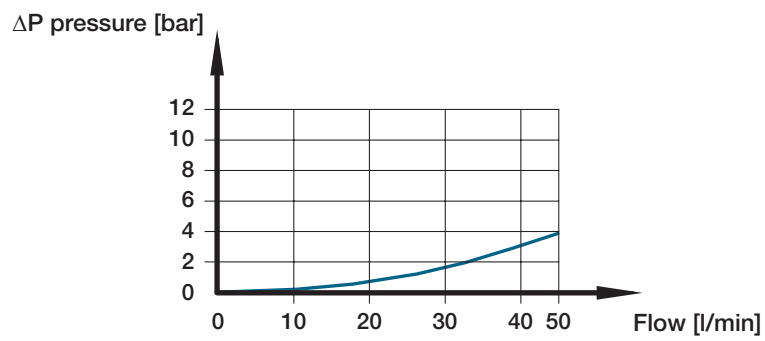

TYPICAL CURVES - EDM10A/EDS10A

All information and diagrams in this manual refer to a mineral base oil ISO-VG46 at $40^{\circ} \pm 5^{\circ}\text{C}$ temperature (32 cSt kinematic viscosity).

PERFORMANCE DATA - Pressure characteristic as function of flow

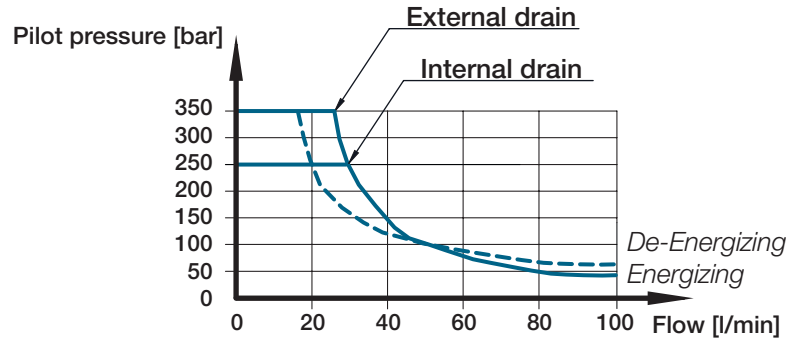

PRESSURE DROP

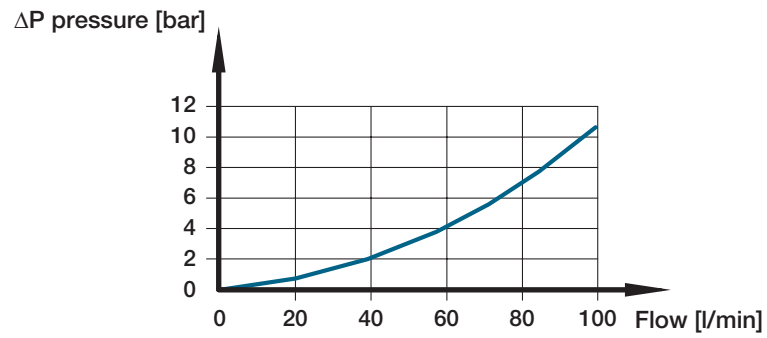



TECHNICAL DATA

All performances in this catalogue are obtained using mineral based hydraulic oil 46 cSt viscosity at 40°C (ISO VG 46 viscosity class). All diverters go through functional testing at these conditions before shipment.

HYDRAULIC STANDARD SPECIFICATIONS

Hydraulic fluid **Mineral Oil HL, HLP (DIN 51524)** phosphate ester (HFD-R)
 Fluid temperature range **-20°C +80°C [-4°F +176°F]**
 Fluid viscosity range **10 ÷ 380 cSt**
 Max contamination level **9 (NAS 1638)** - 20/18/15 (ISO 4406:1999)
 Recommended filtration **B10 > 75** - (ISO 16889:20008)

MATERIAL STANDARD SPECIFICATIONS

Body material **Cast iron**

SEALS

O-Rings: **Buna N** (acrylonitrile butadiene), also named **NBR** (according to ASTM), compatible with fluids having mineral oil base, water in oil emulsions, and water glycol fluids. These seals are standard for temperatures within the range -20°C and +80°C

Back-up rings and Slide rings: **strengthened PTFE** (Politetrafluoroethylene like Teflon®, Lubriflon®, Ecoflon®, or similar).

Special FPM (Viton®) seals are available on request.

Note: the seal materials are compatible with the fluids normally used in hydraulic systems; in case of special fluids, if you suspect incompatibility between the fluid used and the standard seals, contact the EBI motion controls service network.

HYDRAULIC FLUID

Mineral oil based hydraulic fluids suitable for hydraulic systems can be used; they should have physical lubricating and chemical properties as specified by:

MINERAL OIL BASED HYDRAULIC FLUIDS HL (DIN 51524 part 1)

MINERAL OIL BASED HYDRAULIC FLUIDS HLP (DIN 51524 part 2)

For use of environmentally friendly fluids (vegetable or polyglycol base), or other fluids, please contact EBI.

OIL AND SOLUTIONS - ISO 6743/4	(°C) MIN	(°C) MAX	COMPATIBLE SEAL
Mineral Oil HL, HM or HLP	-25	+80	NBR
Oil in water emulsion HFA	+5	+55	NBR
Oil in water emulsion HFB	+5	+55	NBR
Polyglycol-based aqueous solution HFC	-10	+60	NBR

Hydraulic fluids are available in different viscosity classes identified by the ISO VG number, which corresponds to the kinematic viscosity at 40°C. Here is a table showing typical viscosity changes between 0°C and 100°C for mineral oil based fluids having various viscosity classes. The fluid should be selected with the aim to achieve an appropriate operating viscosity at the expected working temperature.

VISCOSITY CLASS AND FILTRATION DATA			
Viscosity class	kinematic viscosity (cSt)		
	maximum (0° C)	medium (40° C)	minimum (100° C)
ISO VG 10	90	10	2.4
ISO VG 22	300	22	4.1
ISO VG 32	420	32	5.0
ISO VG 46	780	46	6.1
ISO VG 68	1400	68	7.8
ISO VG 100	2560	100	9.9

FLUID CLEANLINESS REQUIREMENTS

The cause of malfunctions in hydraulics is often found to be excessive fluid contamination. The hard contaminant particles in the fluid wear the hydraulic components and prevent the poppets from re-seating, with consequent internal leakage and system inefficiency. For the correct operation it is necessary to adopt filtration methods which guarantee for life the specified fluid cleanliness level. It is important to ensure that hydraulic fluids are brought to the appropriate cleanliness level prior filling up the systems, and, when in doubt, also to flush the hydraulic components prior to installation.

FILTRATION RATIO $BETA_x$:

It is the ratio between the number of particles before and after the filter with diameter larger than X micron.

ABSOLUTE FILTRATION RATIO ISO 4572:

It is the diameter X of the largest particle with $BETA_x \geq 75$.

CONTAMINATION CLASS ISO 4406:

It is expressed by 3 scale numbers representing respectively: the number of particles equal to or larger than 4µm, the number of particles equal to or larger than 6µm, the number of particles equal to or larger than 14µm contained in 1 ml of fluid.

CONTAMINATION CLASS NAS 1638:

it's expressed by one scale numbers representing the number of particles of different size ranges contained in 1 ml of fluid.

FILTRATION RECOMMENDATION				
Type	Nominal filtration (micron)	Absolute filtration rating ISO 4572 ($BETA_{x \geq 75}$)	Contamination class	
			ISO 4406	NAS 1638
System/components operating at HIGH PRESSURE > 250 bar HIGH DUTY CYCLE APPLICATIONS Systems/components with LOW dirt tolerance	10	X = 10... 12	19/17/14	8
System/components operating at MEDIUM HIGH PRESSURE HIGH DUTY CYCLE APPLICATIONS Systems/components with MODERATELY dirt tolerance	15	X = 12... 15	20/18/15	9
System/components operating at LOW PRESSURE < 100 bar LOW DUTY CYCLE APPLICATIONS Systems/components with GOOD dirt tolerance	25	X = 15... 25	21/19/16	10



Attention:

If the filtration demands are not met, the valve poppets can jam in the open position, with the result that the valve remains actuated. It is not possible to force back jammed poppets mechanically.

APPLICATION AND SAFETY GUIDELINES

STORAGE OF NEW PRODUCTS

Encapsulated by a protective wrapping, the products shall not be exposed to direct sunlight nor to source of heat or ozone and kept in a dry place at a temperature between -20°C $+50^{\circ}\text{C}$.

SAFETY GUIDELINES

During any operation on diverters, it is recommended to pay attention to components surfaces temperature.

STOCKING DIVERTERS

Encapsulated by a protective wrapping, the diverters shall not be exposed to direct sunlight nor to source of heat or ozone (like electric motors running) and kept in a dry place at a temperature between -20°C $+50^{\circ}\text{C}$

DIVERTERS INSTALLATION

It is recommended to follow these steps:

- Inspect the sub-plate to ensure that it is in good conditions and no external contaminant is present
- Check that O-Rings are intact and correctly positioned
- Don't tighten screws or connectors more than the maximum torque specified in the catalogue.

INLET VOLTAGE AND WORKING DUTY

To obtain correct operation and long life of coils it is necessary that the operating voltage fluctuations do not exceed $+5\%$ -10% of nominal voltage.

The working duty ED of a coil is the ratio between energized time and full cycle time.

All coils are rated for ED = 100% provided that temperature limit of their insulation class is not exceeded.



Attention:

These guidelines are not intended to be considered as complete

ORDERING CODES - MONOBLOCK DIVERTER

The order code below provides an example of **MONOBLOCK DIVERTER EDM08A** with standard configuration. This example represents a EDM08A with solenoid kit, plug without drain and SAE arrangement. See pages 19 - 25 for more information about the different options available.

Product	1	2	3	4
E D M 0 8 A	B D 6 1 2 S	S 6 2	A R 0 1	R D 0 1

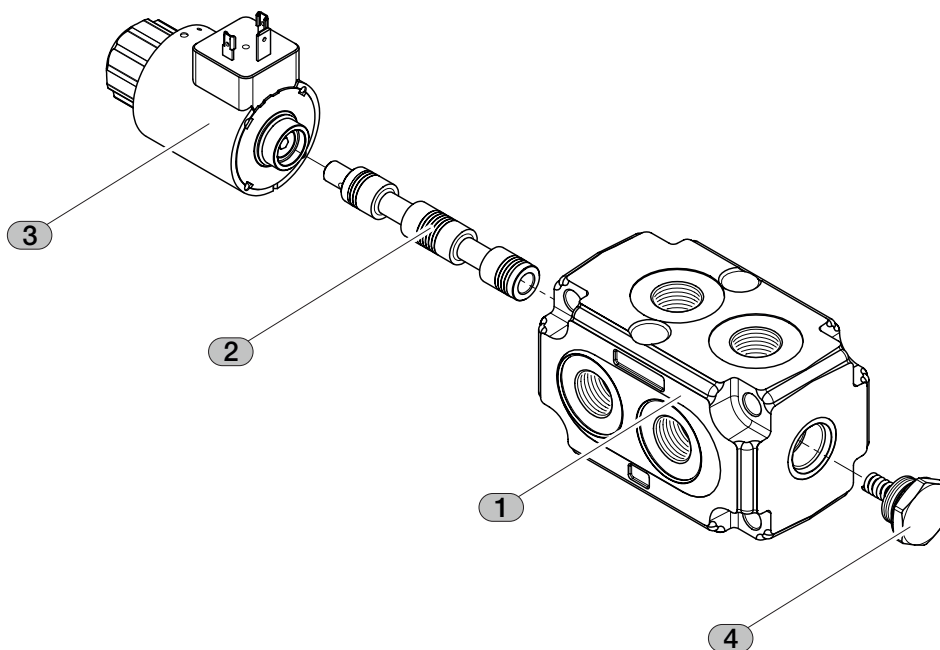

POSITION	CODE	DESCRIPTION	PAGE
	EDM08A	Product	19
1	BD612S	Body classification	22
2	S62	Assembly spool	23
3	AR01	Solenoid kit	24
4	RD01	Plug kit	25

PRODUCT	DESCRIPTION	NOMINAL FLOW	THREAD PORTS
EDM08A	Monoblock diverter	50 (l/min) - 14 [GPM]	G 3/8 - 3/4 16 UNF (SAE8) - G 3/8 JIS B 2351
EDM10A	Monoblock diverter	100 (l/min) - 28 [GPM]	G 1/2 - 7/8 14 UNF (SAE10) - G 1/2 JIS B 2351

ORDERING CODES - STACKABLE DIVERTER

The order code below provides an example of **STACKABLE DIVERTER EDS08A** with standard configuration. This example represents a EDS08A with solenoid kit, plug without drain and SAE arrangement. See pages 20 - 25 for more information about the different options available.

Product	1	2	3	4	5	2	3	3	5
EDS08A	N2	BD612S	S62	AR01	RD01	BD612S	S62	AR01	RD01

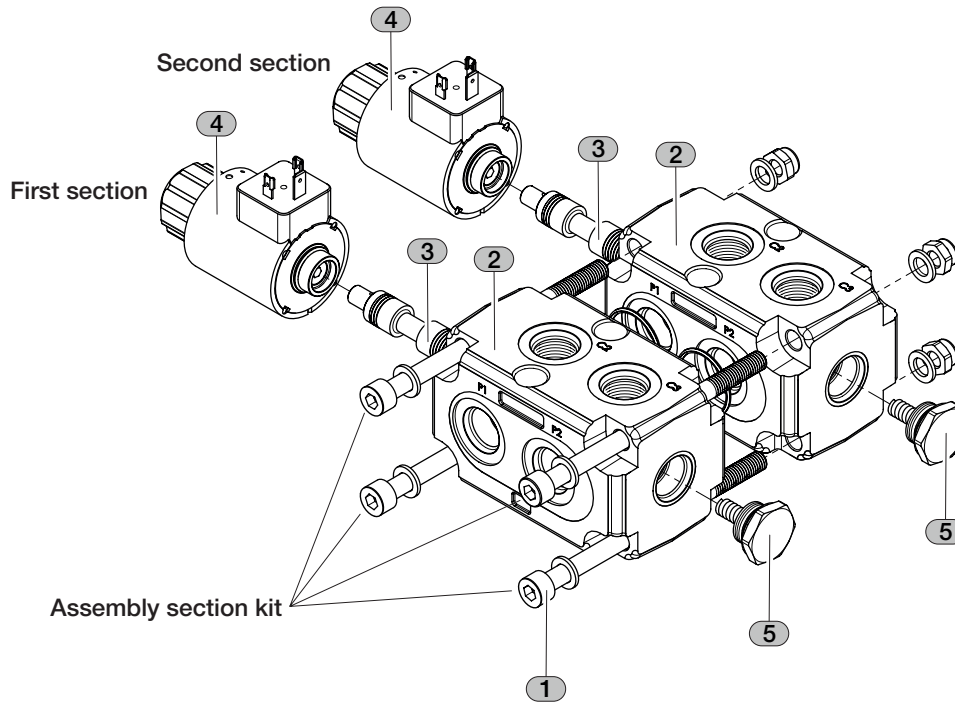

	POSITION	CODE	DESCRIPTION	PAGE
info		EDS08A	Product	20
	1	N2	Assembly section kit	21
first section	2	BD612S	Body classification	22
	3	S62	Assembly spool	23
	4	AR01	Solenoid kit	24
	5	RD01	Plug kit	25
second section	2	BD612S	Body classification	22
	3	S62	Assembly spool	23
	4	AR01	Solenoid kit	24
	5	RD01	Plug kit	25



Note:

Ordering code from position 2 to 5, must be repeated for each section.

The maximum number of sections available is 4.

EXAMPLE OF EDS08A WITH 4 SECTION:

EDS08A N4
BD612S S61 AR01 RD01
BD612S S61 AR01 RD01
BD612S S61 AR01 RD01
BD612S S61 AR01 RD01

PRODUCT	DESCRIPTION	NOMINAL FLOW	THREAD PORTS
EDS08A	Stackable diverter	50 (l/min) - 14 [GPM]	G 3/8 - 3/4 16 UNF (SAE8) - G 3/8 JIS B 2351
EDS10A	Stackable diverter	100 (l/min) - 28 [GPM]	G 1/2 - 7/8 14 UNF (SAE10) - G 1/2 JIS B 2351

ASSEMBLY SECTION

All stackable diverters include an assembly section kit. Each assembly section is composed by 4 screw, 8 growers and 4 nuts. Screw's lenght depends on the number of sections.

EXAMPLE OF EDS10A N2

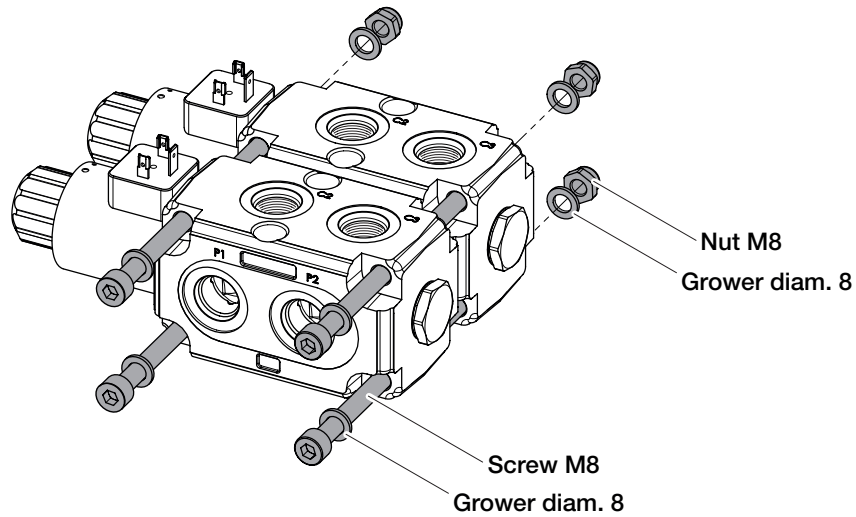

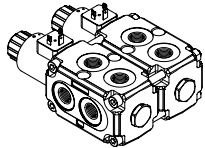
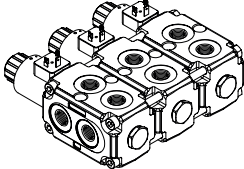
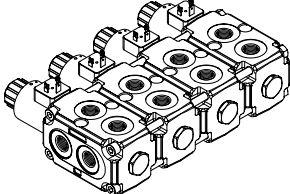
CODE	DESCRIPTION	LENGHT SCREW	CLAMPING TORQUE	DRAWING
N2	Assembly for 2 sections	125 mm - 4.925 in	15/17 Nm	
N3	Assembly for 3 sections	190 mm - 7.486 in	15/17 Nm	
N4	Assembly for 4 sections	255 mm - 10.047 in	15/17 Nm	

BODY CLASSIFICATION

Product	1	2	3	4
E D M 0 8 A	B D 6 1 2 S	S 6 2	A R 0 1	R D 0 1

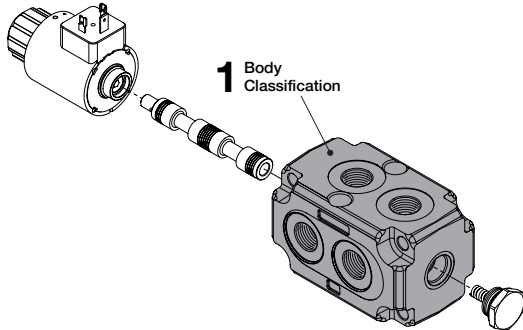

Diverter arrangement body is available in two configurations: SAE thread or BSP thread. All threads present in each body are equal. Body with JIS threads are available on request.



Note:

Body with check valve are available only with spool type S63

CODE	DESCRIPTION	DRAWING	EDM08A	EDM10A
			EDS08A	EDS10A
BD612S	Standard body with ports P1-P2-C1-C4-C2-C3 3/4"-16 UNF (SAE8)		•	
BD612B	Standard body with ports P1-P2-C1-C4-C2-C3 G 3/8		•	
BD612J	Standard body with ports P1-P2-C1-C4-C2-C3 G 3/8 JIS B 2351		•	
BD622S	Standard body with check valves 3/4"-16 UNF (SAE8)		•	
BD622B	Standard body with check valves G 3/8		•	
BD613S	Standard body with ports P1-P2-C1-C4-C2-C3 7/8"-14 UNF (SAE10)			•
BD613B	Standard body with ports P1-P2-C1-C4-C2-C3 G 1/2			•
BD613J	Standard body with ports P1-P2-C1-C4-C2-C3 G 1/2 JIS B 2351			•
BD623S	Standard body with check valves 7/8"-14 UNF (SAE10)			•
BD623B	Standard body with check valves G 1/2			•



Note:

All arrangement bodies are equipped with 2 spring pins and 2 o-rings.

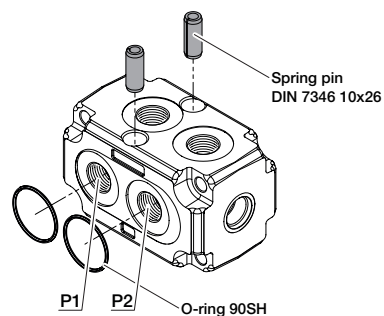

ASSEMBLY SPOOL

Product	1	2	3	4
E D M 0 8 A	B D 6 1 2 S	S 6 2	A R 0 1	R D 0 1

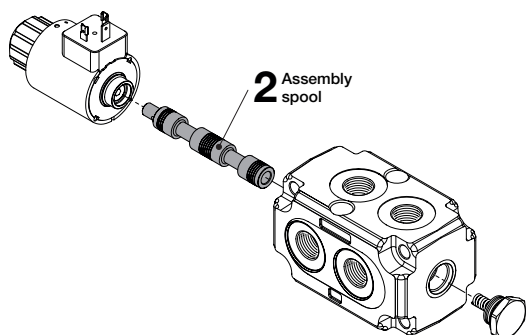

Each diverter contains a spool; each spool is compatible with all solenoid actuation type and all return action type.

The spools of the diverters can be mounted in two modality: **STANDARD circuit** and **REVERSE circuit**.

If you wish to change the mounting modality, swap the position of the solenoid actuation kit and return action kit; the position of the body does not change.

CODE	DESCRIPTION	SYMBOL
S61	Spool 2 positions with ports CLOSED in transit position - STANDARD	
S62	Spool 2 positions with ports CONNECTED in transit position - STANDARD	
S61R	Spool 2 positions with ports CLOSED in transit position - REVERSE	
S62R	Spool 2 positions with ports CONNECTED in transit position - REVERSE	
S63	Spool 2 positions with ports CONNECTED in transit position - STANDARD only external drain	

STANDARD CIRCUIT REVERSE CIRCUIT

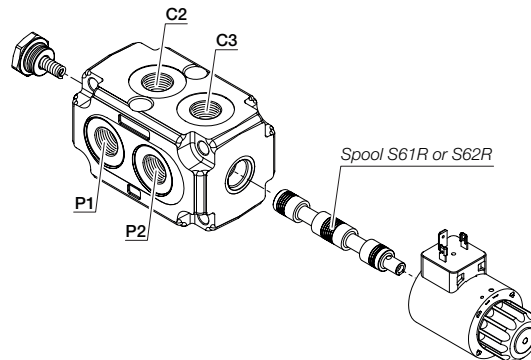
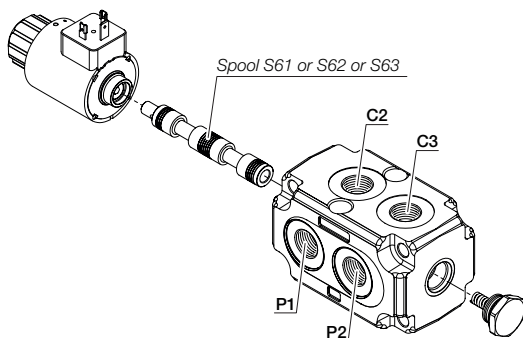

SOLENOID ACTUATION TYPE

Product	1	2	3	4
E D M 0 8 A	B D 6 1 2 S	S 6 2	A R 0 1	R D 0 1

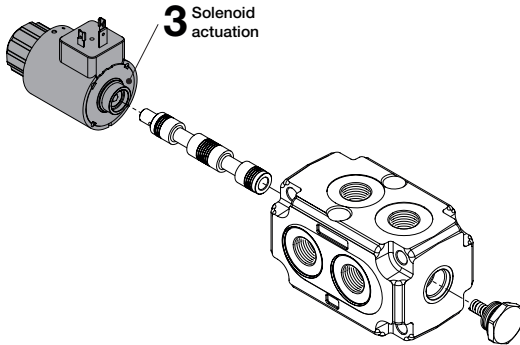

Solenoid actuation type is available in 3 configurations; all solenoids are perfectly interchangeable.

- DIN 43650 ISO 4400
- DEUTSCH DT04
- AMP JUNIOR Class H

For different applications or connector type, contact our Sales Office.

CODE	DESCRIPTION	CONNECTOR TYPE	INSULATION CLASS
AR01	Solenoid kit (12 VDC - Class H)	DIN 43650 ISO 4400	IP65
AR02	Solenoid kit (24 VDC - Class H)	DIN 43650 ISO 4400	IP65
AR03	Solenoid kit (12 VDC - Class H)	DEUTSCH DT04-2P-L	IP69
AR04	Solenoid kit (24 VDC - Class H)	DEUTSCH DT04-2P-L	IP69
AR05	Solenoid kit (12 VDC - Class H)	AMP JUNIOR	IP65
AR06	Solenoid kit (24 VDC - Class H)	AMP JUNIOR	IP65
AR07	Actuation kit without coil		
AR08	Solenoid kit (12 VDC - Class H) with override knob	DIN 43650 ISO 4400	IP65
AR09	Solenoid kit (24 VDC - Class H) with override knob	DIN 43650 ISO 4400	IP65
AR10	Pneumatic actuation (G 1/4)		
AR11	Pneumatic actuation (7/16-20 UNF)		

With external drain Pilot Pressure = min. 5 bar (7p psi) / With internal drain Pilot Pressure = 1/10 of working pressure



Note:

Solenoid actuation kit is equipped with solenoid cartridge, coil, o-rings and plastic plug keeping coil (see drawing on the right).

EXAMPLE OF AR01 KIT

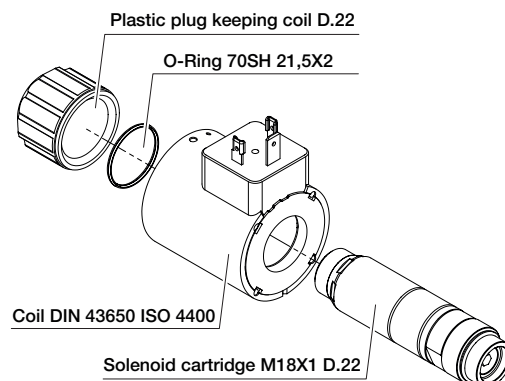

TECHNICAL SPECIFICATIONS

voltage	power	resistance	current
12 VDC	32.7 W	4.41 Ohm	2.72 A
24 VDC	31 W	18.6 Ohm	1.29 A
12 VDC	32.7 W	4.41 Ohm	2.72 A
24 VDC	31 W	18.6 Ohm	1.29 A

RETURN ACTION TYPE

Product	1	2	3	4
E D M 0 8 A	B D 6 1 2 S	S 6 2	A R 0 1	R D 0 1

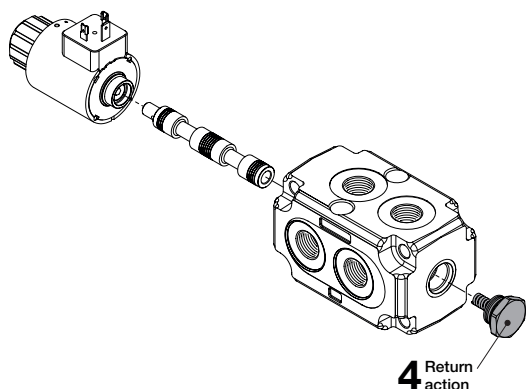

Each diverter can be set up in two configurations:

- Internal drain
- External drain

The transformation from one circuit to another can be done by replacing the return action plug kit. For different applications, contact our Sales Office.

CODE	DESCRIPTION	DRAWING	SYMBOL
RD01	Plug kit INTERNAL drain		
RD02	Plug kit EXTERNAL drain (Port 7/16-20 UNF SAE4) <i>Only for arrangement body with SAE port (BD612S - DB613S)</i>		
RD03	Plug kit EXTERNAL drain (Port G 1/4) <i>Only for arrangement body with BSP port (BD612B - BD613B)</i>		
RD04	Plug kit EXTERNAL drain (Port G 1/4 JIS) <i>Only for arrangement body with BSP JIS port (BD612J - BD613J)</i>		



Note:
Return action plug kit is equipped with plug, o-ring and spring (see following drawing).

EXAMPLE OF RD01 PLUG

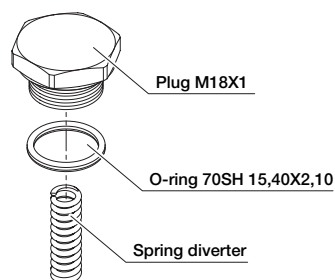



COMPATIBILITY TABLE

BODY TYPE	SPOOL TYPE				
	S61	S61R	S62	S62R	S63
BD612S	•	•	•	•	•
BD612B	•	•	•	•	•
BD612J	•	•	•	•	•
BD622S					•
BD622B					•
BD613S	•	•	•	•	•
BD613B	•	•	•	•	•
BD613J	•	•	•	•	•
BD623S					•
BD623B					•

BODY TYPE	PLUG TYPE			
	RD01	RD02	RD03	RD04
BD612S	•	•		
BD612B	•		•	
BD612J	•			•
BD622S	•			
BD622B	•			
BD613S	•	•		
BD613B	•		•	
BD613J	•			•
BD623S	•			
BD623B	•			

INSTALLATION AND MAINTENANCE

The following drawing represents a complete assembly. The example shown is a monoblock diverter EDM10A and the main tightening torques are shown.

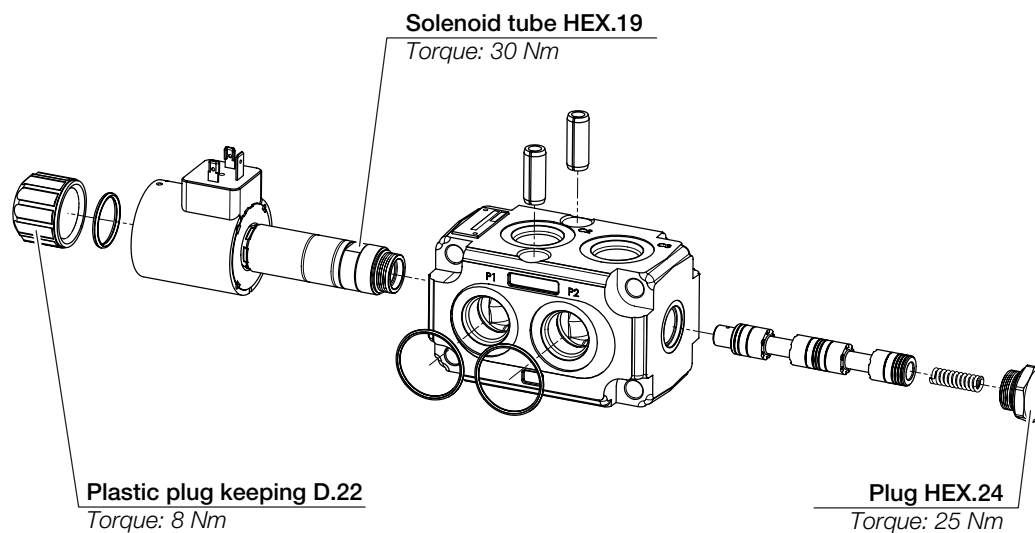

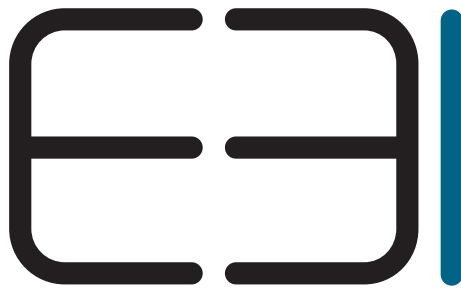

engineering beyond imagination

EBI MOTION CONTROLS S.r.l

Via Andrea Costa 11/2 40057
Cadriano Fraz. di Granarolo dell'Emilia (BO)
TEL. +39 051.0188.800
FAX 051.701.093

info@ebimc.com
www.ebimc.com