

ESJ02E is the answer of EBI for the hall effect double axis Electronic Joystick market need.

FUNCTIONS AND BENEFITS

- Compact design
- Easy installation
- Precise control
- Optimized for EBI control proportional control valves

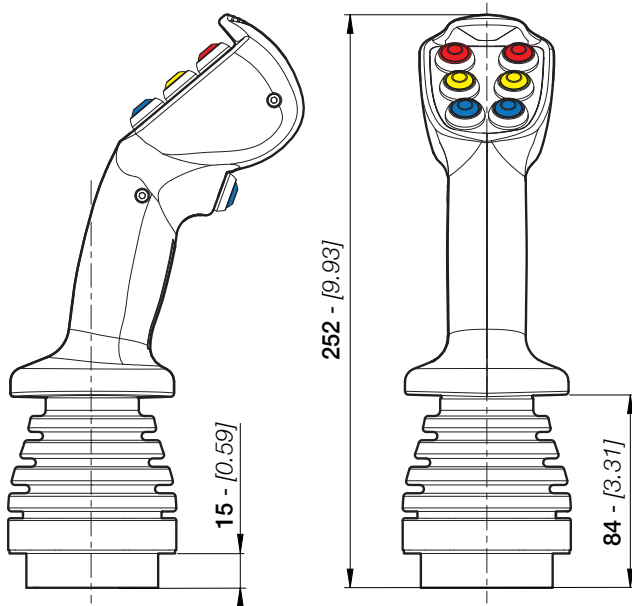
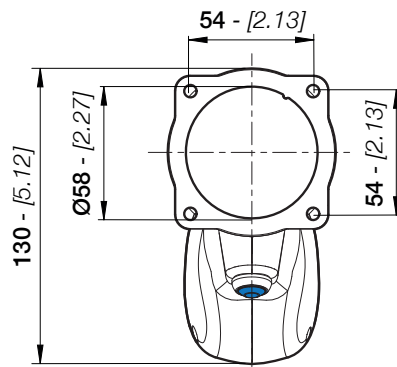

ELECTRICAL SPECIFICATIONS

- **Supply voltage:** nominal voltage 24V, operative voltage 8-36V
- **Protection:** Reverse polarity and Short-circuit protection
- **Communication protocol:** CANopen, SAE J1939, others on request

ENVIRONMENTAL SPECIFICATIONS

- **Storage and operating temperature:** -40°C – +85°C
- **EMC:** According to EN 12895, EN 61000-4-3, EN 61000-6-3, EN 61000-4-2, EN 61000-4-8
- **MTTF:** high (at least 100 years) verification according to EN ISO 13849-1/-2



EHC1 HANDLE

EHC1 is designed to guarantee flexibility and high level of customization. The ergonomic shape allows long duty cycles and excellent comfort for the operator. A wide range of configurable options (buttons, rollers, switches, rockers) allow to fit various machines design in terms of shape, layout and color.

For the Handle configuration, please check ESJ02A catalogue pages 25 – 30.

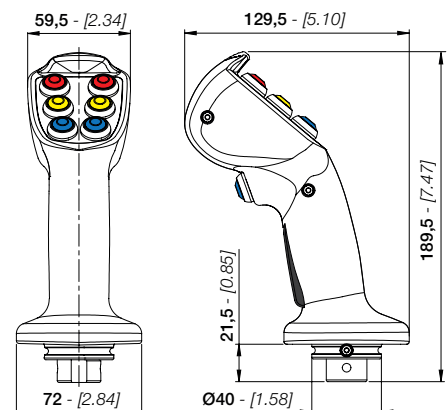

ESJ02E

Electronic joystick



TECHNICAL SPECIFICATIONS

requirement - function	implementation		
	CANopen	SAE J1939	PWM
Sensor	Hall sensor		
Supply voltage (Nominal)	12 - 24 V	12 - 24 V	8 (2,5 A)
Supply voltage (Operating)	8 - 36 V	8 - 36 V	8 - 36 V
Reverse polarity protection	•	•	•
Short-circuit protection	•	•	•
Max. power consumption (current) - 3 activations at the same time	< 100 mA	< 100 mA	< 8 A
Linearity	± 2.5 %		
Neutral position	3° ± 1° (after lifecycle test: max. ± 4°)		
Max. deflection angle	24° ± 1.5°		
Analog inputs on grip (thumbwheel, mini-joystick, potentiometer, etc.)	see EHC1 Handle		
Digital inputs on grip (pushbuttons and other switches)			
Connector type: Deutsch DTM04-12P	-	-	•

MECHANICAL REQUIREMENTS - MOUNTING

requirement - function
Installation depth: ~20 mm (with JST connector on joystick ~40 mm)
Deflection angle on X - Y axis: ± 24° (on main axis)
Resetting to zero-neutral position: Self-resetting to neutral (center) position
Dpop test: 0.5 Kg from a height of 1 m

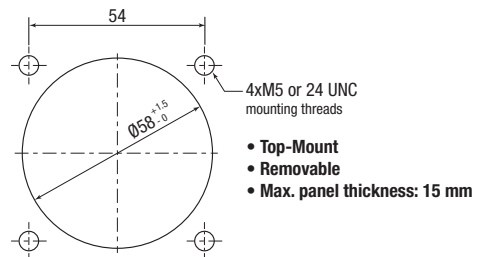

Max. deflection force: X/Y Axis	Max. pulling force	Max. push force
<p>F = 500 N</p> <p>(no permanent deformation or damages and neutral position must remain as specified)</p>	<p>F = 1000 N</p> <p>(no permanent deformation or damages and neutral position must remain as specified)</p> <p>FORCE APPLICATION ON CENTER AXIS</p>	