



*Single pedal pilot control valve*

# ESP02A

Rev. 03 • September, 2024  
TECHNICAL CATALOGUE





## HISTORY OF REVISIONS

DATE	PAGE	CHANGED	REV.
October, 2018	-	First edition	00
November, 2019	19-20	Updated diagrams metering curve	01
May, 2023	21-22	Updated tables metering curve	02
September, 2024	24-25	Spare parts list added	03

## ABOUT THE MANUAL

This manual contains the technical instructions for the servocontrol ESP02A. All information given in this manual is current and valid according to the information available at the time of publication. The data specified above only serve to describe the product. EBI Motion controls reserves to modify or revise the instructions without prior notice.

EBI Motion controls is not responsible for any damage caused by an incorrect use of the product. Please visit [www.ebimc.com](http://www.ebimc.com) for the most recent version of this manual.

**CONTENTS**

<b>4</b>	<b>INTRODUCTION</b>
<b>5</b>	<b>GENERAL INFORMATION</b> HYDRAULIC OPERATING PRINCIPLE
<b>6</b>	<b>GENERAL INSTRUCTIONS</b> INTENDE USE WARRANTY GENERAL SAFETY INSTRUCTIONS WARNING SYMBOL PRODUCT IDENTIFICATION UNITS OF MEASURE - CONVERSION FACTORS
<b>8</b>	<b>DIMENSIONS - HYDRAULIC SYMBOL</b> STANDARD CONNECTIONS
<b>11</b>	<b>PORT DETAILS</b>
<b>12</b>	<b>TECHNICAL DATA</b> HYDRAULIC STANDARD SPECIFICATIONS MATERIAL STANDARD SPECIFICATIONS GENERAL STANDARD SPECIFICATIONS SEALS
<b>13</b>	<b>HYDRAULIC FLUID</b>
<b>15</b>	<b>APPLICATION AND SAFETY GUIDELINES</b> STORAGE OF NEW PRODUCT SAFETY GUIDELINES
<b>16</b>	<b>ORDERING CODES</b> BODY CLASSIFICATION FIXING PLATE PEDAL ASSEMBLY CONTROL ASSEMBLY METERING CURVE RETURN SPRING
<b>24</b>	<b>SPARE PARTS LIST</b>



## INTRODUCTION

### SERVOCONTROLS

EBI motion controls servocontrols (joysticks and foot pedals) are used to control the work and drive hydraulics of modern mobile machines with high accuracy, safety and optimal performance. EBI motion controls servocontrols are maintenance free and have a long life cycle, are suited for specialized applications for a variety of mobile equipment such as:

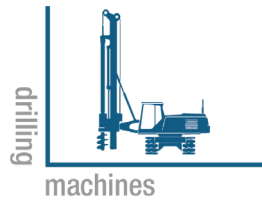

## ESP02A

### PILOT CONTROL DEVICE IN PEDAL DESIGN FOOT PEDAL 1 AXIS



- Progressive and sensitive operation.
- Precise pressure control.
- Low operating effort.
- Optimised angular movements of foot pedal.
- Control element protected with rubber bellow.
- Damping system option.
- High durability and Maintenance free.

GENERAL INFORMATION

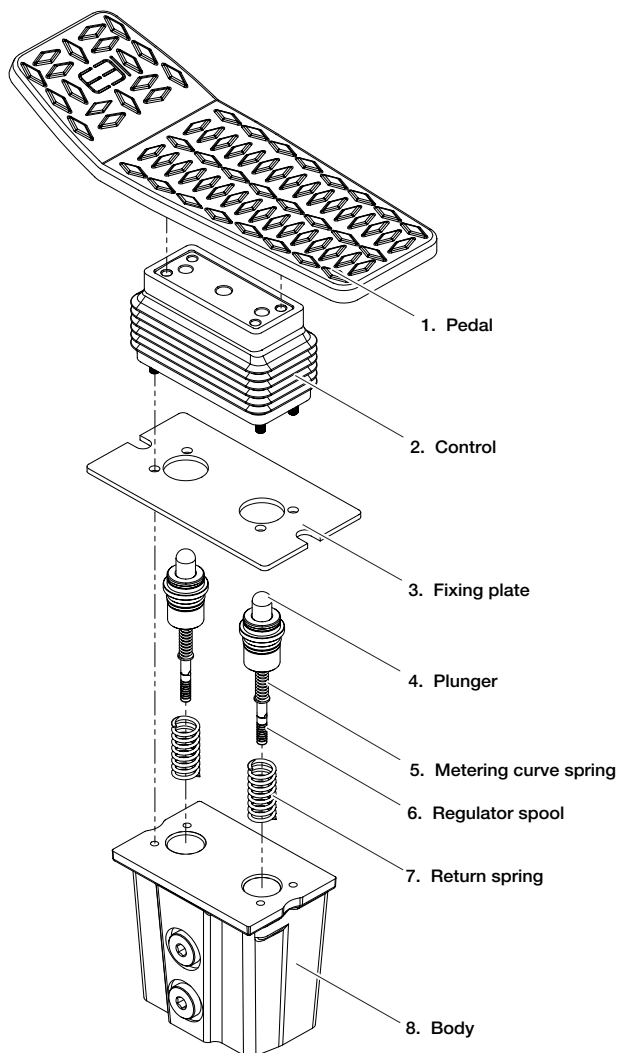

HYDRAULIC OPERATING PRINCIPLE

Foot pedal control device ESP02A is normally used to control a single double acting spool as a travel pedal on a tracked vehicle. This valve operates on the pressure reducing concept, using a constant inlet pressure, and providing a metered variable outlet pressure as a direct result of the pedal displacement.

ESP02A basically consists of a foot pedal (1), two pressure reducing valves and body (8). Each pressure reducing valve includes regulator spool (6), metering curve spring (5), return spring (7) and plunger (4). At rest, the pedal is held in the neutral position by return springs. Service ports are connected to the tank port T via regulator spool.

When foot pedal is actuated, plunger is pressed against the return spring and metering curve spring. Metering curve spring initially moves spool downwards and closes the connection between the relevant port and tank port T. At the same time, the A/B port is connected to port P via regulator spool. The control (2) phase starts as soon as the spool finds its balance between the force of metering curve spring and the force that results from the hydraulic pressure in the relevant port. Due to the interaction of spool and metering curve spring, the pressure in the relevant ports is proportional to the stroke of plunger and hence to the position of pedal. This closed-loop pressure control in relation to the position of foot pedal and the properties of metering curve spring allows a proportional hydraulic control of directional valves and high response control valves for hydraulic pumps and motors.

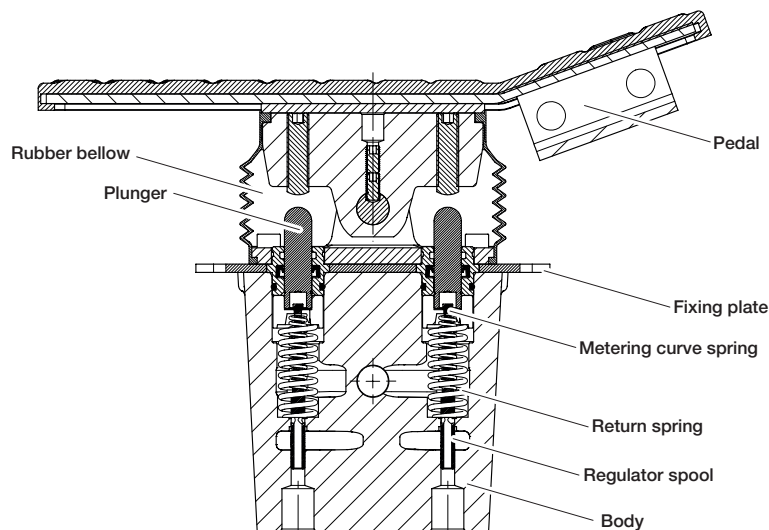



## GENERAL INSTRUCTIONS

### INTENDED USE

Servocontrol ESP02A is designed for industrial use.

### WARRANTY

Check the package and the product for transport damage when receiving goods. The package is not meant for long term storage; protect the product appropriately.

Do not dismantle the product. The warranty is void if the product has been disassembled.

The manufacturer is not responsible for damages resulting from misinterpreted, noncompliance, incorrect, or improper use of the product that goes against the instructions given in this document.

### GENERAL SAFETY INSTRUCTIONS

The following instructions apply to all procedures associated with the product. Read these instructions carefully and follow them closely.

- Use necessary personal protective equipment when working with the product.
- Support the product properly; make sure the product cannot fall over or turn around by accident.
- Use only appropriate equipment and attachments for lifting and transferring the product.
- Always use the lifting equipment properly and check the load-bearing capacity.
- Prevent unintended use of the product during installation and maintenance procedures.

### WARNING SYMBOL

The following symbols can be used in this manual:



**Note:**  
Useful information



**Danger:**  
Danger of death or injury



**Attention:**  
May cause damage to the product

PRODUCT IDENTIFICATION

The product identification data can be found on the identification plate attached to the EBI product.

SERIAL NUMBER

all manufacturing data and all sales data can be found with the serial number

PART NUMBER CODE

It is a number univocally identifying the configuration and pressure setting of a valve

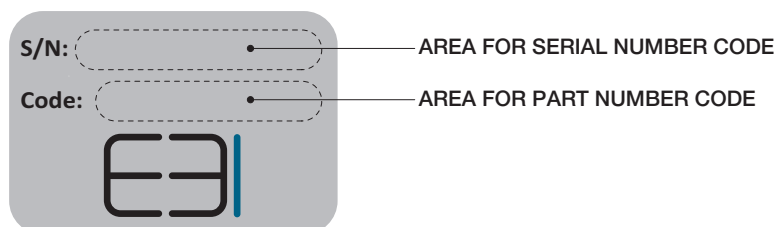

Note:

Serial number and part number code have 9 characters (letters and numbers).

UNITS OF MEASURE - CONVERSION FACTORS

LENGHT	FLOW RATE	MASS	FORCE WEIGHT	PRESSURE
1 mm = 0,0394 in	1 l = 0,2200 gal UK	1 kg = 2,205 lb	1 Nm = 0,1020 Kgf	1 bar = 100000 Pa
1 in = 25,4 mm	1 l = 0,2642 gal US	1 lb = 0,4536 kg	1 Kgf = 9,8067 Nm	1 bar = 14,5 psi
	1 gal UK = 4,546 l			1 Pa = 0,0001 bar
	1 gal UK = 1,2010 gal US			1 Pa = 0,00014 psi
	1 gal US = 3,785 l			1 psi = 0,0689 bar
	1 gal US = 0,8327 gal UK			1 psi = 6890 Pa

## DIMENSIONS - HYDRAULIC SYMBOL

This drawing represents a ESP02A with standard assembly pedal and BSP configuration.

Pedal deflection:  $\pm 11.3^\circ$

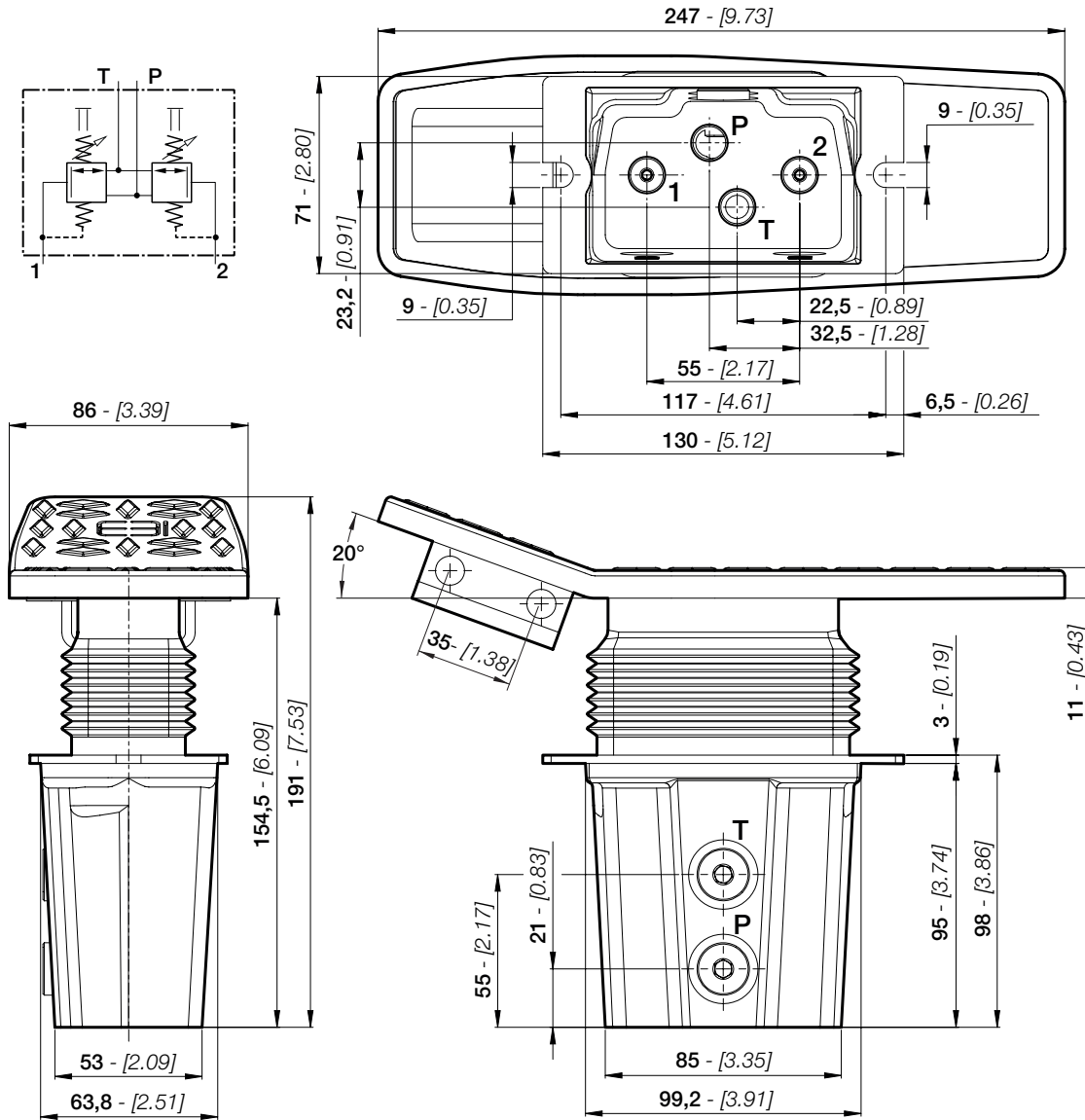

## STANDARD CONNECTIONS

TYPE	BSP (ISO 1179-1)	UN-UNF (ISO 11926-1)
INLET - P	G 1/4	9/16-18 UNF
PORTS - A/B	G 1/4	9/16-18 UNF
OUTLET - T	G 1/4	9/16-18 UNF



This drawing represents a ESP02A with P02 assembly pedal and BSP configuration.  
 Pedal deflection:  $\pm 11.3^\circ$

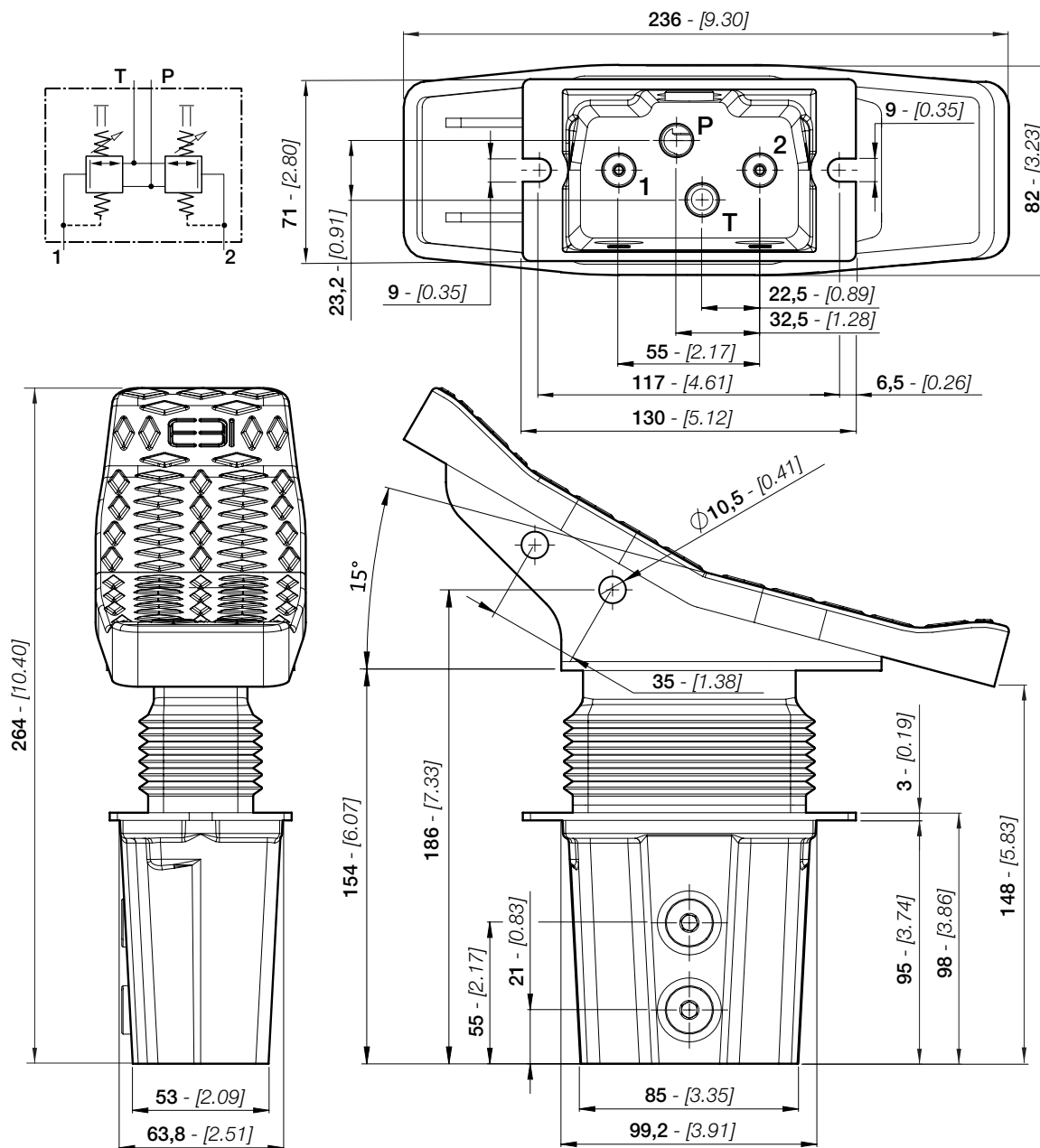

STANDARD CONNECTIONS

TYPE	BSP (ISO 1179-1)	UN-UNF (ISO 11926-1)
INLET - P	G 1/4	9/16-18 UNF
PORTS - A/B	G 1/4	9/16-18 UNF
OUTLET - T	G 1/4	9/16-18 UNF

This drawing represents a ESP02A with P03 assembly pedal and BSP configuration.  
 Pedal deflection:  $\pm 11.3^\circ$

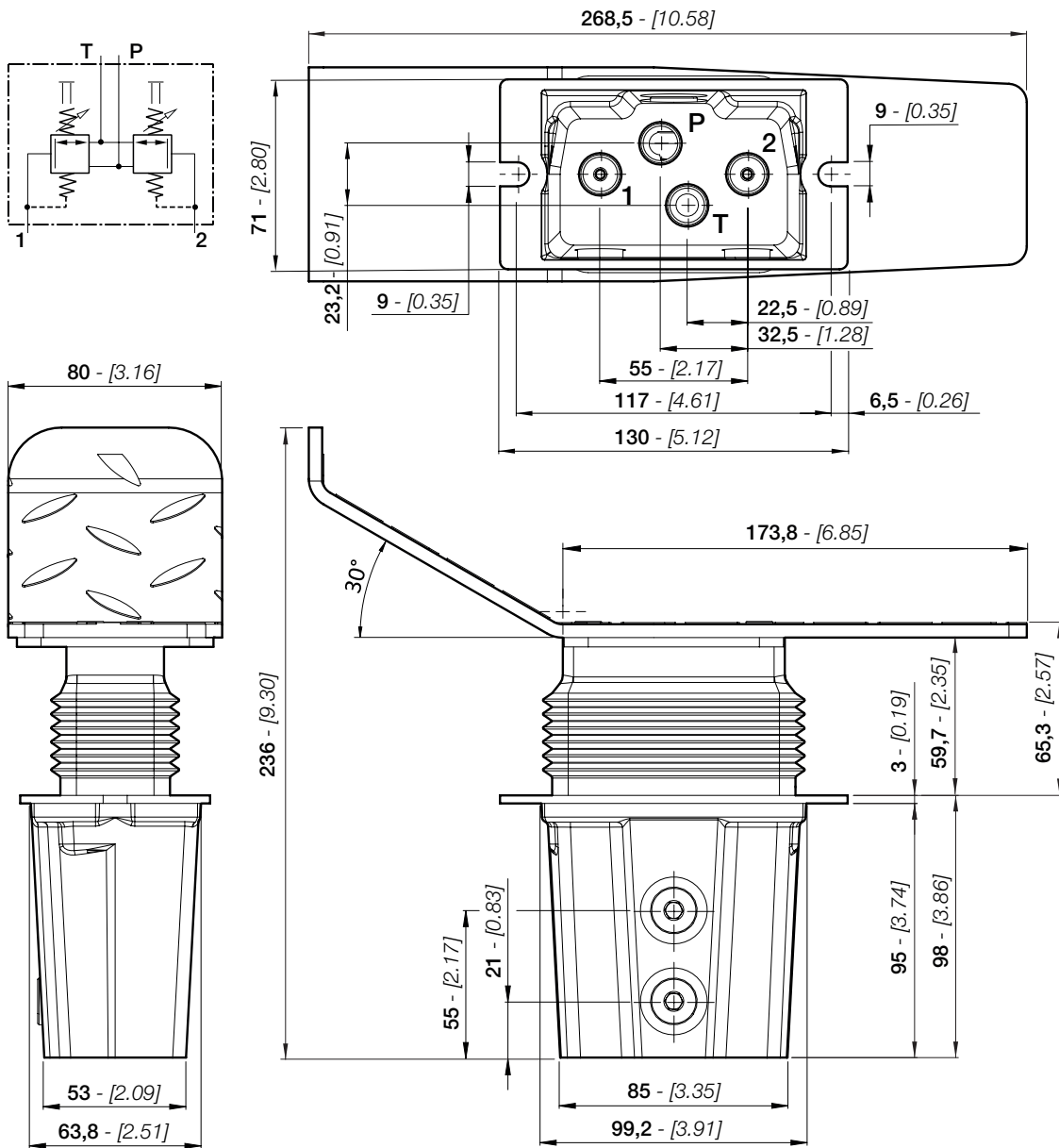

## STANDARD CONNECTIONS

TYPE	BSP (ISO 1179-1)	UN-UNF (ISO 11926-1)
INLET - P	G 1/4	9/16-18 UNF
PORTS - A/B	G 1/4	9/16-18 UNF
OUTLET - T	G 1/4	9/16-18 UNF

## PORT DETAILS

The connection port size is indicated by an ordering code common for all EBI products. Following tables show all available connections.

BSP THREADS ISO 1179-1	D	C		B		A		CODE
	UNI-ISO 228	mm	inc	mm	inc	mm	inc	
	G 1/4	13	0.51	19	0.75	1	0.094	<b>1B</b>
	G 3/8	13	0.51	25	0.98	1	0.04	<b>2B</b>
	G 1/2	15	0.59	29	1.14	1.5	0.06	<b>3B</b>
	G 3/4	17	0.67	36	1.42	1.5	0.06	<b>4B</b>
	G 1	19	0.75	45	1.77	2	0.08	<b>5B</b>

UN/UNF THREADS ISO 11926-1	D	C		B		L		M		K	A		CODE
	ASA-B1-1	mm	inc	mm	inc	mm	inc	mm	inc		mm	inc	
	9/16-18 UNF (SAE6)	13	0.51	26	1.02	15.6	0.61	2.5	0.098	12°	1	0.04	<b>1S</b>
	3/4-16 UNF (SAE8)	15	0.59	30	1.18	20.6	0.81	2.6	0.102	15°	1.5	0.06	<b>2S</b>
	7/8-14 UNF (SAE10)	17	0.67	34	1.34	23.9	0.94	2.6	0.102	15°	1.5	0.06	<b>3S</b>
	1"1/16-12 UNF (SAE12)	20	0.79	41	1.61	29.2	1.15	3.3	0.13	15°	1.5	0.06	<b>4S</b>
	1"5/16-12 UNF (SAE16)	20	0.79	50	1.97	35.5	1.40	3.3	0.13	15°	2	0.08	<b>5S</b>



## TECHNICAL DATA

All performances in this catalogue are obtained using mineral based hydraulic oil 46 cSt viscosity at 40°C (ISO VG 46 viscosity class). All ESP02A go through functional testing at these conditions before shipment.

### HYDRAULIC STANDARD SPECIFICATIONS

Maximum input pressure .....	<b>100 bar - [1450 psi]</b>
Maximum back pressure on tank line .....	<b>3 bar - [43,5 psi]</b>
Control max flow on ports.....	<b>15 l/min - [4 GPM]</b>
Hysteresis .....	<b>&lt; 1 bar - [&lt; 14,5 psi]</b>
Hydraulic fluid .....	<b>Mineral Oil HL, HLP (DIN 51524) phosphate ester (HFD-R)</b>
Fluid temperature range .....	<b>-20°C +80°C [-4°F +176°F]</b>
Fluid viscosity range .....	<b>10 ÷ 380 cSt</b>
Max contamination level .....	<b>9 (NAS 1638) - 20/18/15 (ISO 4406:1999)</b>
Recommended filtration .....	<b>β = 0 &gt; 75 - (ISO 16889:20008)</b>
Leakage (single port) .....	<b>3 cm<sup>3</sup>/min - (with 100 bar of pressure)</b>

### MATERIAL STANDARD SPECIFICATIONS

Body material .....	<b>Cast iron</b>
Plunger material .....	<b>Stainless steel</b>
Plunger guide material .....	<b>Brass</b>

### GENERAL STANDARD SPECIFICATIONS

Type of connection .....	<b>BSP thead (iso 1179-1) - SAE thead (iso 11926-1)</b>
--------------------------	---

### SEALS

**O-Rings:** **Buna N** (acrylonitrile butadiene), also named **NBR** (according to ASTM), compatible with fluids having mineral oil base, water in oil emulsions, and water glycol fluids.

These seals are standard for temperatures within the range -20°C and +80°C

**Back-up rings and Slide rings:** **strengthened PTFE** (Politetrafluoroetilene like Teflon®, Lubriflon®, Ecoflon®, or similar).

Special FPM (Viton®) seals are available on request.

**Note:** the seal materials are compatible with the fluids normally used in hydraulic systems; in case of special fluids, if you suspect incompatibility between the fluid used and the standard seals, contact the EBI motion controls service network.

## HYDRAULIC FLUID

Mineral oil based hydraulic fluids suitable for hydraulic systems can be used; they should have physical lubricating and chemical properties as specified by:

MINERAL OIL BASED HYDRAULIC FLUIDS HL (DIN 51524 part 1)

MINERAL OIL BASED HYDRAULIC FLUIDS HLP (DIN 51524 part 2)

For use of environmentally friendly fluids (vegetable or polyglycol base), or other fluids, please contact EBI.

OIL AND SOLUTIONS - ISO 6743/4	(°C) MIN	(°C) MAX	COMPATIBLE SEAL
Mineral Oil HL, HM or HLP	-25	+80	NBR
Oil in water emulsion HFA	+5	+55	NBR
Oil in water emulsion HFB	+5	+55	NBR
Polyglycol-based aqueous solution HFC	-10	+60	NBR

Hydraulic fluids are available in different viscosity classes identified by the ISO VG number, which corresponds to the kinematic viscosity at 40°C. Here is a table showing typical viscosity changes between 0°C and 100°C for mineral oil based fluids having various viscosity classes. The fluid should be selected with the aim to achieve an appropriate operating viscosity at the expected working temperature.

VISCOSITY CLASS AND FILTRATION DATA			
Viscosity class	kinematic viscosity (cSt)		
	maximum (0° C)	medium (40° C)	minimum (100° C)
ISO VG 10	90	10	2.4
ISO VG 22	300	22	4.1
ISO VG 32	420	32	5.0
ISO VG 46	780	46	6.1
ISO VG 68	1400	68	7.8
ISO VG 100	2560	100	9.9

### FLUID CLEANLINESS REQUIREMENTS

The cause of malfunctions in hydraulics is often found to be excessive fluid contamination. The hard contaminant particles in the fluid wear the hydraulic components and prevent the poppets from re-seating, with consequent internal leakage and system inefficiency. For the correct operation it is necessary to adopt filtration methods which guarantee for life the specified fluid cleanliness level. It is important to ensure that hydraulic fluids are brought to the appropriate cleanliness level prior filling up the systems, and, when in doubt, also to flush the hydraulic components prior to installation.

#### FILTRATION RATIO $BETA_x$ :

It is the ratio between the number of particles before and after the filter with diameter larger than X micron.

#### ABSOLUTE FILTRATION RATIO ISO 4572:

It is the diameter X of the largest particle with  $BETA_x \geq 75$ .

**CONTAMINATION CLASS ISO 4406:**

It is expressed by 3 scale numbers representing respectively: the number of particles equal to or larger than 4µm, the number of particles equal to or larger than 6µm, the number of particles equal to or larger than 14µm contained in 1 ml of fluid.

**CONTAMINATION CLASS NAS 1638:**

It is expressed by one scale numbers representing the number of particles of different size ranges contained in 1 ml of fluid.

<b>FILTRATION RECOMMENDATION</b>				
Type	Nominal filtration (micron)	Absolute filtration rating ISO 4572 (BETA <sub>x</sub> ≥75)	Contamination class	
			ISO 4406	NAS 1638
<b>System/components operating at</b> <i>HIGH PRESSURE &gt; 250 bar</i> <i>HIGH DUTY CYCLE APPLICATIONS</i> <b>Systems/components with</b> <i>LOW dirt tolerance</i>	10	X = 10... 12	19/17/14	8
<b>System/components operating at</b> <i>MEDIUM HIGH PRESSURE</i> <i>HIGH DUTY CYCLE APPLICATIONS</i> <b>Systems/components with</b> <i>MODERATELY dirt tolerance</i>	15	X = 12... 15	20/18/15	9
<b>System/components operating at</b> <i>LOW PRESSURE &lt; 100 bar</i> <i>LOW DUTY CYCLE APPLICATIONS</i> <b>Systems/components with</b> <i>GOOD dirt tolerance</i>	25	X = 15... 25	21/19/16	10

**Attention:**

If the filtration demands are not met, the valve poppets can jam in the open position, with the result that the valve remains actuated. It is not possible to force back jammed poppets mechanically.

## APPLICATION AND SAFETY GUIDELINES

### STORAGE OF NEW PRODUCTS

Encapsulated by a protective wrapping, the products shall not be exposed to direct sunlight nor to source of heat or ozone and kept in a dry place at a temperature between  $-20^{\circ}\text{C}$   $+50^{\circ}\text{C}$ .

### SAFETY GUIDELINES

During any operation on servocontrols, it is recommended to pay attention to components surfaces temperature.

The circuit functions are to be so designed that uncontrolled machine movements, caused by the application, are prevented and that it is possible to switch from one function to another.

Take into account all of the application limits, particularly those application limits stated within this technical catalogue.

It is recommended to follow these steps and only trained and competent personnel may carry out any work on EBI motion controls servocontrols:

- Do not direct the jet of a pressure washing unit directly to the unit.
- During operation protection via the rubber boot must be ensured.
- Ensure that all matching surfaces are clean, without contamination.
- Ensure that all seals and back-up rings for the matching surfaces are flawless and correctly placed.
- Do not put any sealing material other than the standard seals.
- During the assembly of the complete servocontrol and/or the group of servocontrol, refer to the hydraulic scheme and to the name assigned to each port.
- Do not hang the servocontrol and/or the group of servocontrol to the hydraulics pipes, but always use the specific fixing holes.
- Place in position the servocontrol, then, by hand, insert the fittings and the locating screws.
- Finally tighten with a calibrated torque wrench and torque up to the specifications shown in the catalogue.
- Use gloves in order to avoid accidental injuries during installation or maintenance.
- Do not grab / handle product from moving parts (i.e. cables, levers,...etc.)
- All servocontrols or groups of servocontrols are attributable to pressure vessels. It's always recommended to place the components in a closed but ventilated compartment, able to protect the environment and users in case of accidental ejection of material under pressure (fittings, pipes, plugs expander... etc.)
- Do not tamper with the servocontrol.
- Before removing or disassembling the complete servocontrol or allowed parts ( as pressure gauge ports, purge plugs, ...etc) it is strongly recommended to vent all hydraulic pressure from the system.
- During the first start of the machine, please ensure that the grounding system is connected and stay away from moving parts.
- In case of allowed adjustments on the valve, any maximum value indicated in catalogue must not be exceeded.



#### Attention:

These guidelines are not intended to be considered as complete

## ORDERING CODES

The order code below provides an example of servocontrol ESP02A with standard configuration. This example represents a ESP02A with standard assembly pedal and SAE configuration. See pages 17 - 23 for more information about the different options available.

product	1	2	3	4	5	6	5	6
E S P 0 2 A	B P A 5 1 S	F P 1	P 0 1	C 0 1	M D 0 1	S 1	M D 0 1	S 1

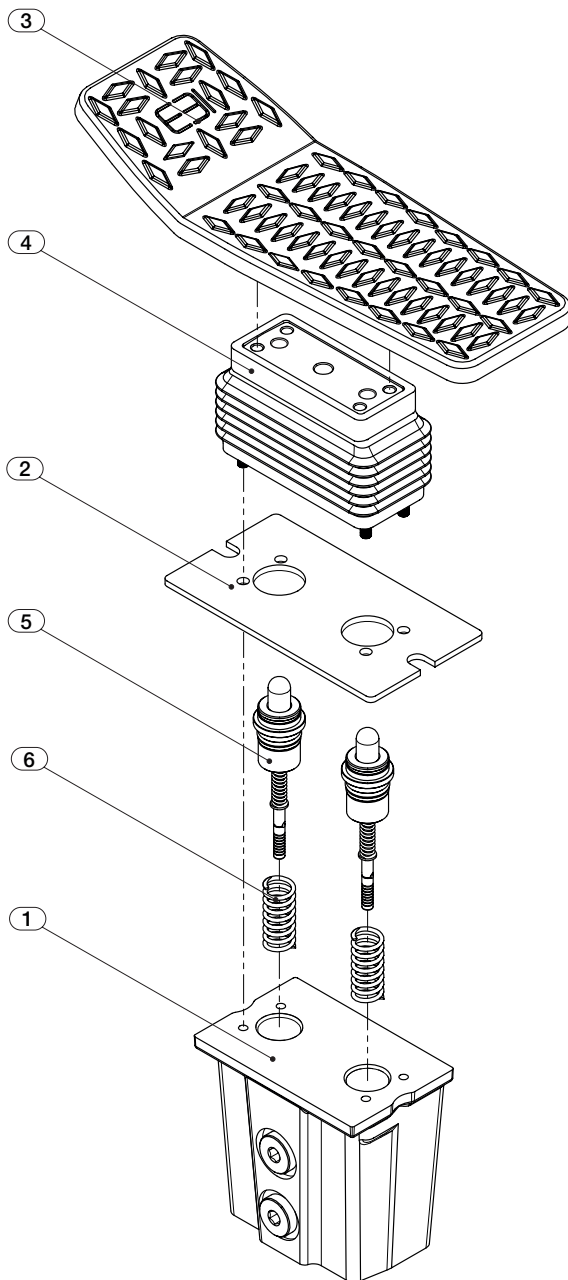

RIF.	CODE	DESCRIPTION	PAGE
1	<b>BPA51S</b>	Body classification	17
2	<b>FP1</b>	Fixing plate	18
3	<b>P01</b>	Pedal assembly	19
4	<b>C01</b>	Control assembly	20
5	<b>MD01</b>	Metering curve (port 1)	21
6	<b>S1</b>	Return spring (port 1)	23
5	<b>MD01</b>	Metering curve (port 2)	21
6	<b>S1</b>	Return spring (port 2)	23



**Note:**

Ordering row 5 and 6 must be repeated for each port.



BODY CLASSIFICATION

product					1	2	3	4	5	6	5	6																				
E	S	P	0	2	A	B	P	A	5	1	S	F	P	1	P	0	1	C	0	1	M	D	0	1	S	1	M	D	0	1	S	1

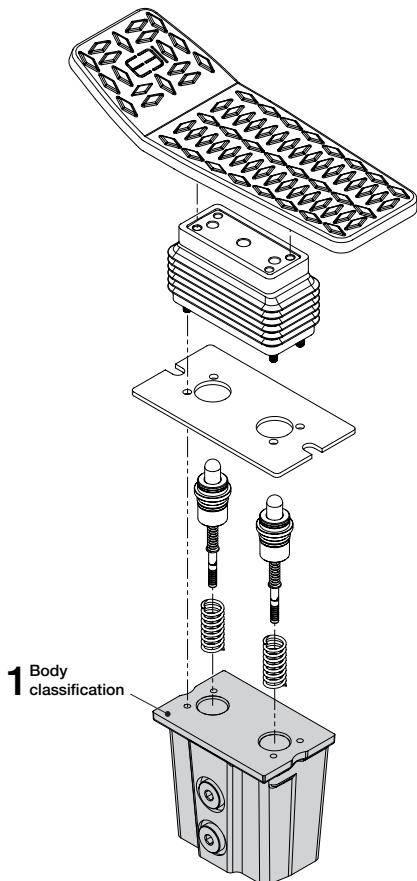

ESP02A body arrangement is available in two configurations: SAE thread or BSP thread.

The maximum flexibility of the body configuration is guaranteed by the positioning of the service ports plug.

Each body arrangement contains 2 plugs.

CODE	DESCRIPTION	DRAWING
BPA51S	Assembly body P-T-A-B lower with ports 9/16"-18 UNF (SAE6)	
BPA51B	Assembly body P-T-A-B lower with ports G 1/4"	
BPA31S	Assembly body P-T side A-B lower with ports 9/16"-18 UNF (SAE6)	
BPA31B	Assembly body P-T side A-B lower with ports G 1/4"	

## FIXING PLATE

product	1	2	3	4	5	6	5	6
E S P 0 2 A	B P A 5 1 S	F P 1	P 0 1	C 0 1	M D 0 1	S 1	M D 0 1	S 1

The fixing plate allows the correct installation of the ESP02A servocontrol on the customer machine system.

FP1 is the standard fixing plate; for different dimensions or features, contact our Sales Office.

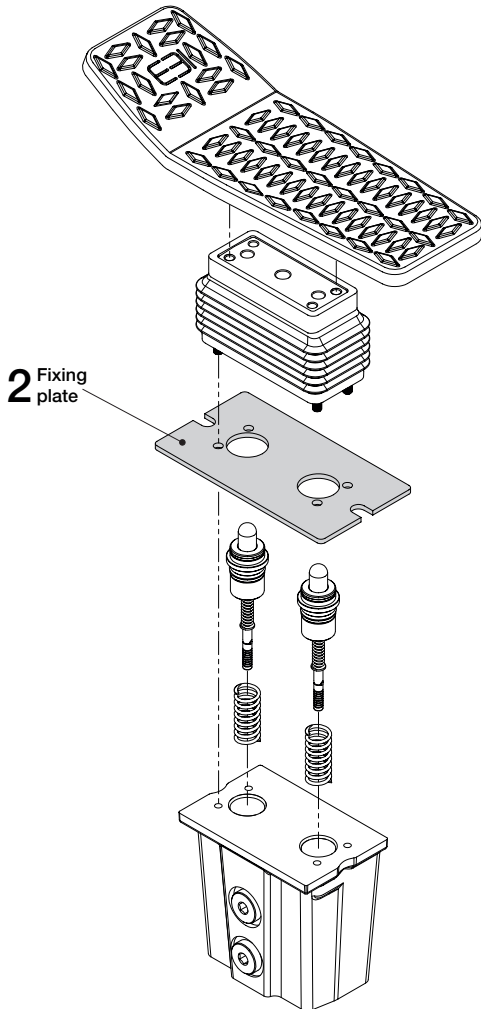

CODE	DESCRIPTION
<b>FP1</b>	Standard fixing plate

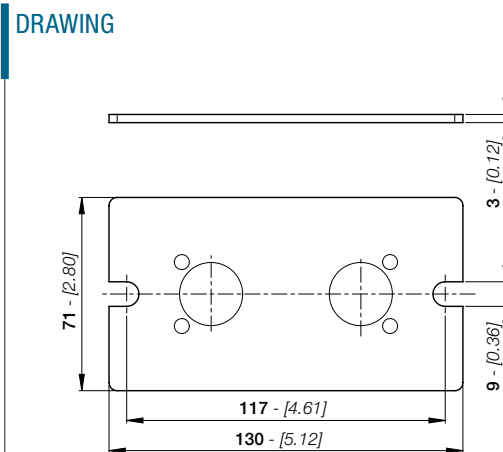

PEDAL CLASSIFICATION

product	1	2	3	4	5	6	5	6
E S P 0 2 A	B P A 5 1 S	F P 1	P 0 1	C 0 1	M D 0 1	S 1	M D 0 1	S 1

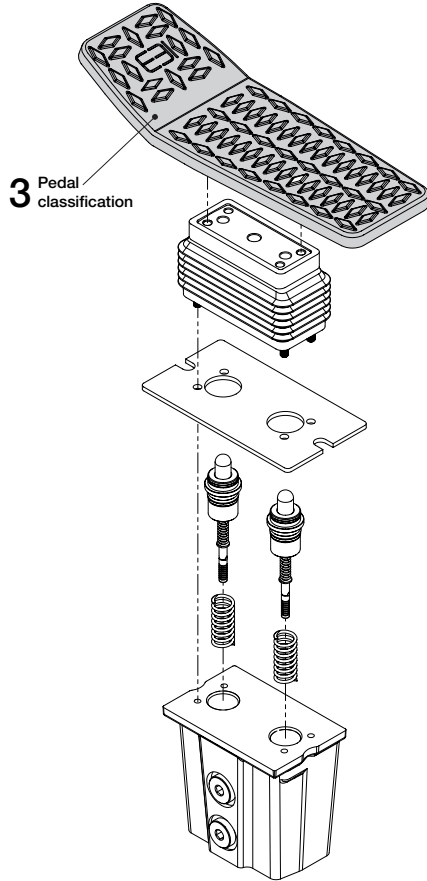

Two different pedals are available; all pedals are interchangeable. Its ergonomic design provides excellent confort for the operator. The P00 version corresponds to the servocontrol without assembly pedal; in this case it is possible to house an external pedal.

CODE	DESCRIPTION	DRAWING
P00	Without pedal (prearrangement)	
P01	Flat pedal with rubber protection	
P02	Flat pedal tilted 30° with rubber protection	
P03	Flat pedal NO slip	

## CONTROL ASSEMBLY

product	1	2	3	4	5	6	5	6
E S P 0 2 A	B P A 5 1 S	F P 1	P 0 1	C 0 1	M D 0 1	S 1	M D 0 1	S 1

Only one configuration is available; for different applications contact our Sales Office.

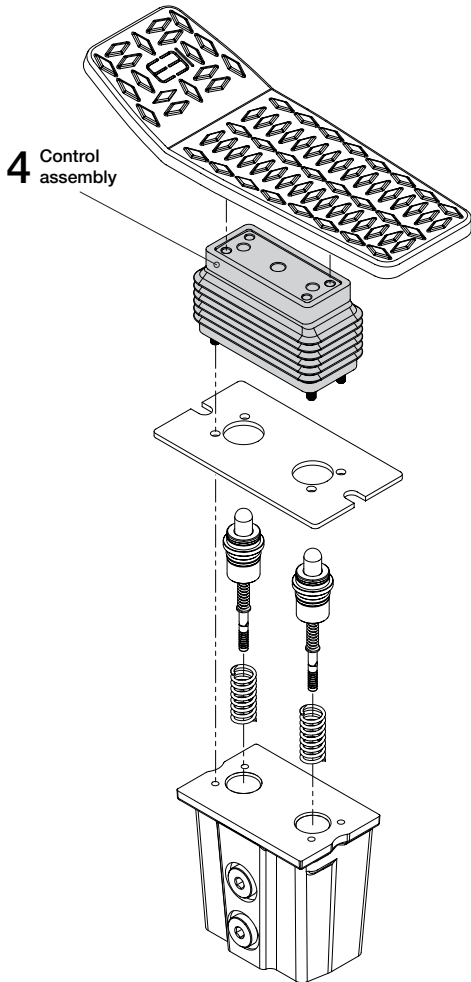

CODE

DESCRIPTION

C01

Foot pedal actuation kit  
with rubber bellow

DRAWING

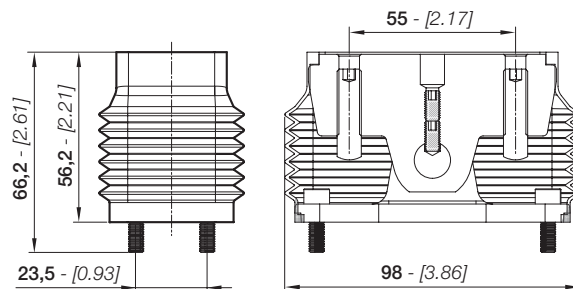

### METERING CURVE

product						1	2	3	4	5	6	5	6																			
E	S	P	0	2	A	B	P	A	5	1	S	F	P	1	P	0	1	C	0	1	M	D	0	1	S	1	M	D	0	1	S	1

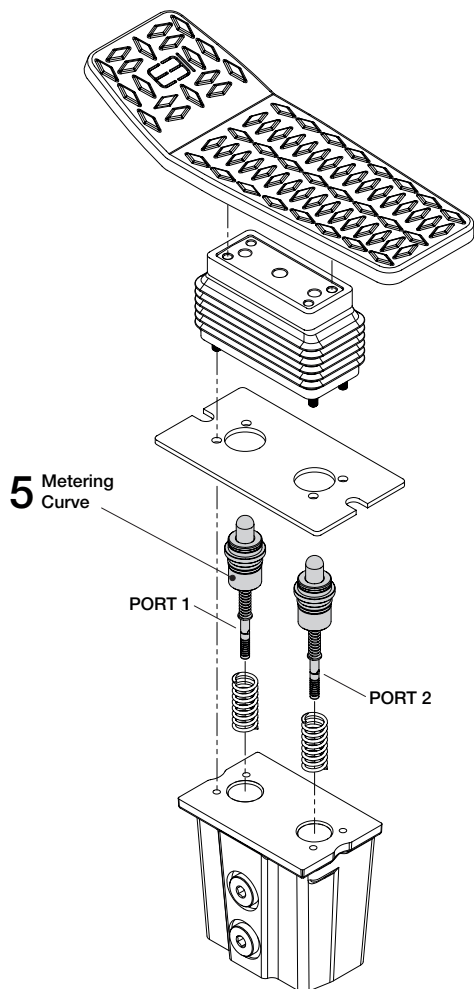

All ESP02A servocontrols are equipped with 2 metering curves (one metering curve each service port).

The metering curve classification depends on the control pressure (bar - *psi*) and stroke length (mm - *in*).

Currently two types of metering curves are available:

- Linear curve with step (MD type)
- Linear curve without step (ME type)

All metering curves are interchangeable.

For different values or different applications please contact our Sales Office.

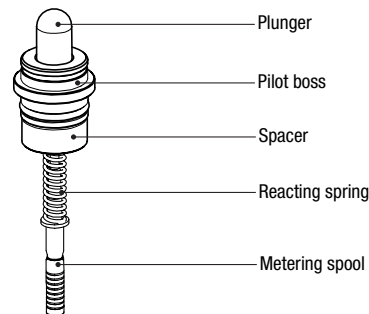

**Note:**

Ordering row 5 must be repeated for each port.

CODE	PRESSURE				STROKE			
	P1		P2		S1		S2	
	bar	psi	bar	psi	mm	in	mm	in
<b>MD01</b>	5	72,5	25	362,5	1	0,04	5	0,20
<b>MD02</b>	5.8	84,1	19.5	282,7	1	0,04	5	0,20
<b>MD03</b>	5	72,5	22	319	1	0,04	5	0,20
<b>MD04</b>	5	72,5	15	217,5	1	0,04	5	0,20
<b>MD05</b>	5	72,5	20	290	1	0,04	5	0,20
<b>MD06</b>	7.5	108,8	29	420,5	1	0,04	5	0,20
<b>MD07</b>	8	116	28	406	1	0,04	5	0,20
<b>MD08</b>	2	29	18	261	1	0,04	5	0,20
<b>MD12</b>	6.8	98.6	23.5	340.7	1	0,04	5	0,20
<b>MD38</b>	2	29	23	333.5	1	0,04	5	0,20

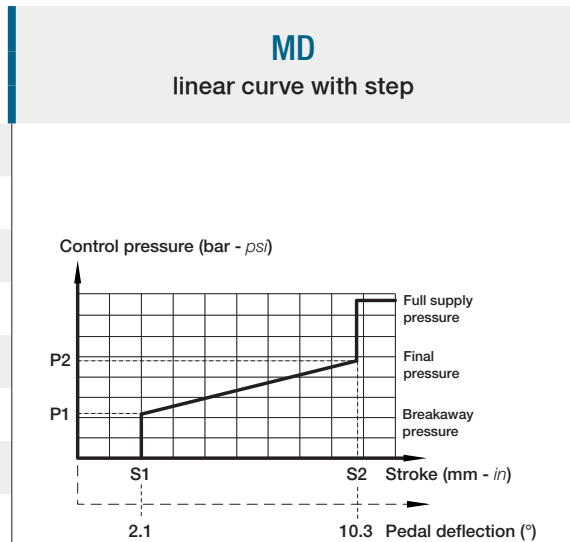

CODE	PRESSURE				STROKE			
	P1		P2		S1		S2	
	bar	psi	bar	psi	mm	in	mm	in
<b>ME01</b>	5	72,5	25	362,5	1	0,04	5.5	0,22
<b>ME02</b>	5.8	84,1	19.5	282,7	1	0,04	5.5	0,22
<b>ME03</b>	5	72,5	22	319	1	0,04	5.5	0,22
<b>ME04</b>	5	72,5	15	217,5	1	0,04	5.5	0,22
<b>ME05</b>	5	72,5	20	290	1	0,04	5.5	0,22
<b>ME06</b>	7.5	108,8	29	420,5	1	0,04	5.5	0,22
<b>ME07</b>	8	116	28	406	1	0,04	5.5	0,22
<b>ME08</b>	2	29	18	261	1	0,04	5.5	0,22
<b>ME39</b>	5.9	85.6	21.1	306	1	0,04	5.5	0,22

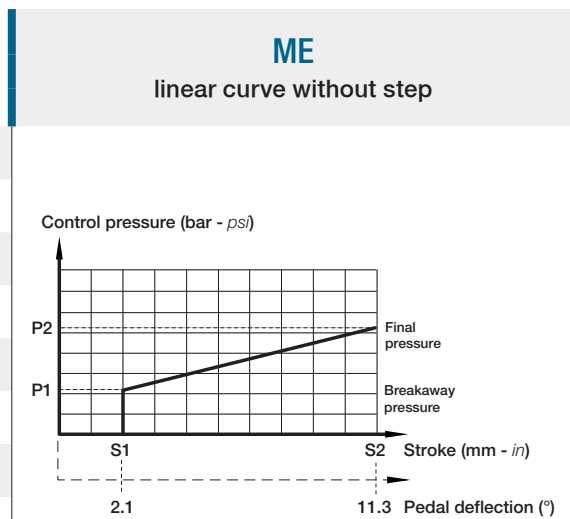

ESP02A can be supplied also with damping system where are required two special metering curves:

- **Damping system with step (MF type)**
- **Damping system without step (MG type)**

RETURN SPRING

product					1					2			3			4			5			6		5			6					
E	S	P	0	2	A	B	P	A	5	1	S	F	P	1	P	0	1	C	0	1	M	D	0	1	S	1	M	D	0	1	S	1

All ESP02A servocontrols are equipped with 2 return springs (one spring each service port).

For different values or different applications please contact our Sales Office.

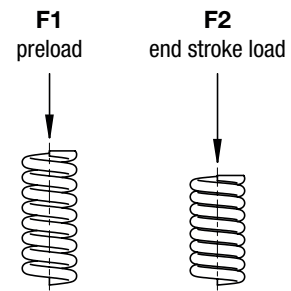
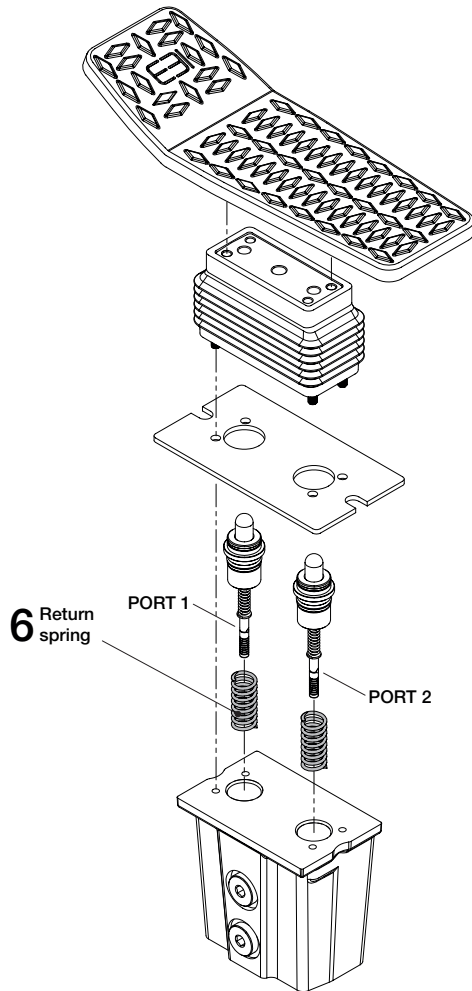

CODE	PRELOAD		END STROKE LOAD	
	N	kgf	N	kgf
<b>S1</b>	94 N	9,60	149 N	15.20

## SPARE PARTS LIST

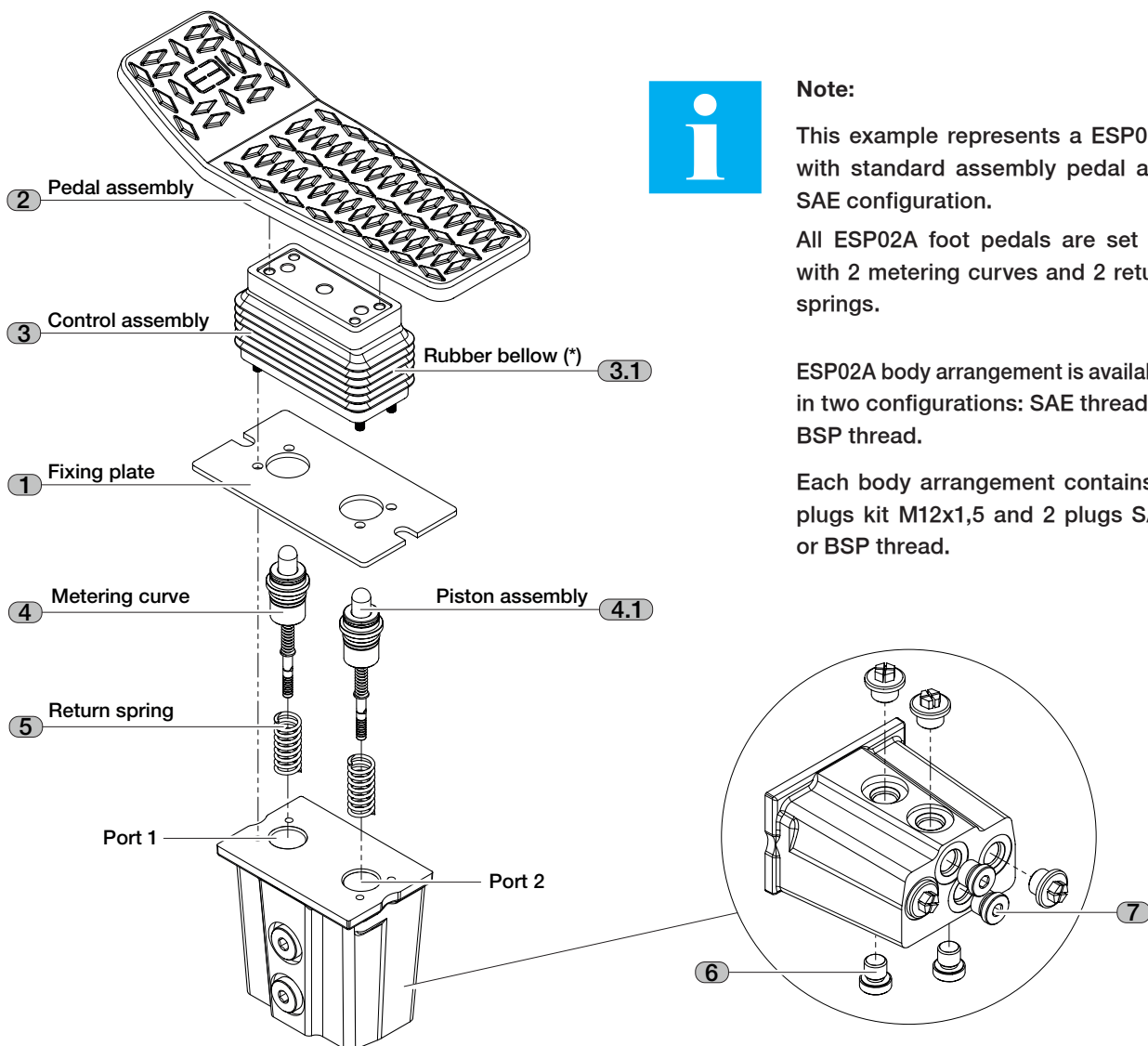

### Note:

This example represents a ESP02A with standard assembly pedal and SAE configuration.

All ESP02A foot pedals are set up with 2 metering curves and 2 return springs.

ESP02A body arrangement is available in two configurations: SAE thread or BSP thread.

Each body arrangement contains 2 plugs kit M12x1,5 and 2 plugs SAE or BSP thread.

REFERENCE	CATALOGUE CODE	ORDER CODE	DESCRIPTION	NOTE
1	<b>FP1</b>	<b>A01210004</b>	Standard fixing plate	
2	<b>P01</b>	<b>A01260002</b>	Flat pedal with rubber protection	
	<b>P02</b>	<b>A01260001</b>	Flat pedal tilted 30° with rubber protection	
	<b>P03</b>	<b>A01260003</b>	Flat pedal NO slip	
3	<b>C01</b>	<b>A01250011</b>	Foot pedal actuation kit	
3.1	<b>EIM120047</b>		Foot pedal rubber bellow	(*) rubber bellow code only
4	<b>MD01</b>	<b>A01160038</b>	METERING CURVE WITH STEP P1 = 5 bar [72.5 psi] P2 = 25 bar [362.5 psi] S1 = 1 mm [0.04 in] S2 = 5 mm [0.20 in]	Each ESP02A contains 2 metering curves
	<b>MD02</b>	<b>A01160005</b>	METERING CURVE WITH STEP P1 = 5,8 bar [84.1 psi] P2 = 19.5 bar [282.7 psi] S1 = 1 mm [0.04 in] S2 = 5 mm [0.20 in]	
	<b>MD03</b>	<b>A01160077</b>	METERING CURVE WITH STEP P1 = 5 bar [72.5 psi] P2 = 22 bar [319 psi] S1 = 1 mm [0.04 in] S2 = 5 mm [0.20 in]	
	<b>MD04</b>	<b>A01160018</b>	METERING CURVE WITH STEP P1 = 5 bar [72.5 psi] P2 = 15 bar [217.5 psi] S1 = 1 mm [0.04 in] S2 = 5 mm [0.20 in]	



REFERENCE	CATALOGUE CODE	ORDER CODE	DESCRIPTION	NOTE	
4	MD05	A01160078	METERING CURVE WITH STEP P1 = 5 bar [72.5 psi] P2 = 20 bar [290 psi] S1 = 1 mm [0.04 in] S2= 5 mm [0.20 in]	Each ESP02A contains 2 metering curves	
	MD06	A01160079	METERING CURVE WITH STEP P1 = 7.5 bar [108.8 psi] P2 = 29 bar [420.5 psi] S1 = 1 mm [0.04 in] S2= 5 mm [0.20 in]		
	MD07	A01160080	METERING CURVE WITH STEP P1 = 8 bar [116 psi] P2 = 28 bar [406 psi] S1 = 1 mm [0.04 in] S2= 5 mm [0.20 in]		
	MD08	A01160068	METERING CURVE WITH STEP P1 = 2 bar [29 psi] P2 = 18 bar [261 psi] S1 = 1 mm [0.04 in] S2= 5 mm [0.20 in]		
	MD12	A01160013	METERING CURVE WITH STEP P1 = 6.8 bar [98.6 psi] P2 = 23.5 bar [340.7 psi] S1 = 1 mm [0.04 in] S2= 5 mm [0.20 in]		
	MD38	A01160042	METERING CURVE WITH STEP P1 = 2 bar [29 psi] P2 = 23 bar [333.5 psi] S1 = 1 mm [0.04 in] S2= 5 mm [0.20 in]		
	ME01	A01160088	METERING CURVE WITHOUT STEP P1 = 5 bar [72.5 psi] P2 = 25 bar [362.5 psi] S1 = 1 mm [0.04 in] S2 = 5.5 mm [0.22 in]	Each ESP02A contains 2 metering curves	
	ME02	A01160064	METERING CURVE WITHOUT STEP P1 = 5,8 bar [84.1 psi] P2 = 19.5 bar [282.7 psi] S1 = 1 mm [0.04 in] S2 = 5.5 mm [0.22 in]		
	ME03	A01160082	METERING CURVE WITHOUT STEP P1 = 5 bar [72.5 psi] P2 = 22 bar [319 psi] S1 = 1 mm [0.04 in] S2 = 5.5 mm [0.22 in]		
	ME04	A01160083	METERING CURVE WITHOUT STEP P1 = 5 bar [72.5 psi] P2 = 15 bar [217.5 psi] S1 = 1 mm [0.04 in] S2 = 5.5 mm [0.22 in]		
	ME05	A01160084	METERING CURVE WITHOUT STEP P1 = 5 bar [72.5 psi] P2 = 20 bar [290 psi] S1 = 1 mm [0.04 in] S2 = 5.5 mm [0.22 in]		
	ME06	A01160085	METERING CURVE WITHOUT STEP P1 = 7.5 bar [108.8 psi] P2 = 29 bar [420.5 psi] S1 = 1 mm [0.04 in] S2 = 5.5 mm [0.22 in]		
	ME07	A01160086	METERING CURVE WITHOUT STEP P1 = 8 bar [116 psi] P2 = 28 bar [406 psi] S1 = 1 mm [0.04 in] S2 = 5.5 mm [0.22 in]		
	ME08	A01160087	METERING CURVE WITHOUT STEP P1 = 2 bar [29 psi] P2 = 18 bar [261 psi] S1 = 1 mm [0.04 in] S2 = 5.5 mm [0.22 in]		
	ME39	A01160066	METERING CURVE WITHOUT STEP P1 = 5.9 bar [85.6 psi] P2 = 21.1 bar [306 psi] S1 = 1 mm [0.04 in] S2 = 5.5 mm [0.22 in]		
	4.1	A02050011			Piston assembly for metering curve With STEP
		A02050070		Piston assembly for metering curve Without STEP	
	5	S1	A01220004	Return spring (94 / 149 N) - [9.60 / 15.20 kgf]	Each ESP02A contains 2 return springs
6	C03010015		Port plug M12x1,5	Each body contains 2 plugs	
7	C03010001		Port plug SAE6	Each body contains 2 plugs	
	C03010002		Port plug G 1/4"		



engineering beyond imagination

**EBI MOTION CONTROLS S.r.l**

Via Andrea Costa 11/2 40057  
Cadriano Fraz. di Granarolo dell'Emilia (BO)  
TEL. +39 051.0188.800  
FAX 051.701.093

[info@ebimc.com](mailto:info@ebimc.com)  
[www.ebimc.com](http://www.ebimc.com)