



Sectional directional control valve

ECS08A

Rev. 02 • September, 2023

TECHNICAL CATALOGUE



.....
Controls



HISTORY OF REVISIONS

DATE	PAGE	CHANGED	REV.
November, 2019	-	First edition	00
November, 2020	15-18-32-38-40	Hydraulic schema and dimensional drawing replaced. Information added on page 38.	01
September, 2023	25-31-32-34-35-45	Float version inserted. Externali piloted dump valve added (type V05). Auxiliary valve V59 type added. Joystick control actuation added. Outlet with PRV and BPU inserted.	02

ABOUT THE MANUAL

This manual contains the technical instructions for the control ESC08A.
All information given in this manual is current and valid according to the information available at the time of publication.
The data specified above only serve to describe the product. EBI Motion controls reserves to modify or revise the instructions without prior notice.

EBI Motion controls is not responsible for any damage caused by an incorrect use of the product.
Please visit www.ebimc.com for the most recent version of this manual.

CONTENTS

4	INTRODUCTION
5	GENERAL INFORMATION
6	QUICK REFERENCE GUIDE
7	APPLICATION AND SAFETY GUIDELINES
10	HYDRAULIC FLUID
12	PORT DETAILS
13	DIMENSIONS
16	TECHNICAL SPECIFICATIONS
	TECHNICAL DATA
17	TYPICAL CURVES
18	CIRCUITS
19	ORDERING CODES
	ASSEMBLY SECTION
	INLET SECTION
	WORK SECTION
	OUTLET SECTION
	OPTION
	ACCESSORIES
	GENERAL CLAMPING TORQUE



INTRODUCTION

CONTROLS

EBC motion controls provides a broad choice of directional control valves expertly developed and tested to meet different market sectors' needs. EBC Control valves are suited for specialized applications for a variety of mobile equipment such as:

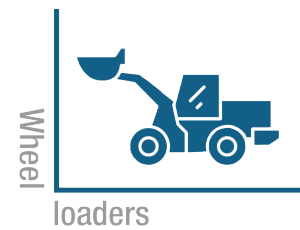
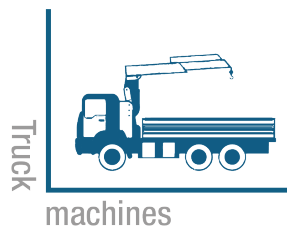
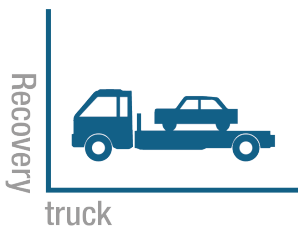
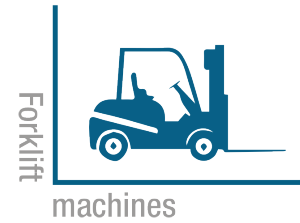
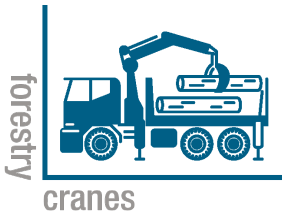

ECS08A

SECTIONAL DIRECTIONAL CONTROL VALVE

- From 1 to 12 working sections.
- Parallel and tandem circuit available.
- Low internal leakage.
- Compact directional valve with low pressure losses.
- Interchangeable spools.
- Wide range of auxiliary valves on the ports.
- Availability of manual, hydraulic, and electrohydraulic actuations.

GENERAL INFORMATION

HYDRAULIC OPERATING PRINCIPLE

Directional control valve ECS08A basically comprises of an inlet section, directional valve sections and an outlet section. It is designed to the 6-way principle and comprises of an arrangement body (1), control spool (3), load holding check valve (2), actuation spool (4), return action spool (5), cavities for the secondary pressure valves or relief/anti-cavitation valves (6), as well as anti-cavitation valves or plug (7).

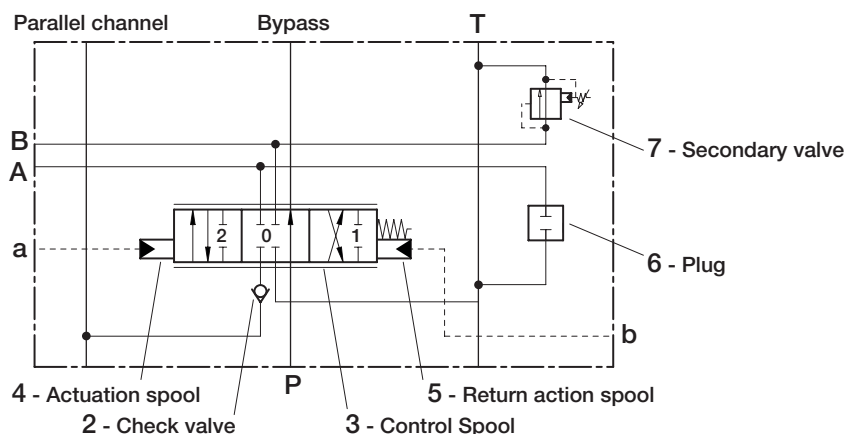

With all of the spool axes in their neutral position the flow passes via the bypass channel at zero pressure to tank. If one of the control spools is actuated then the connection from the pump to the actuator is opened via the fine control grooves, whilst the bypass is throttled by fine control grooves. If the pump pressure exceeds the actuator pressure, the pressure fluid starts to flow over the check valve to the actuator.

With further movement of the control spool the volume of fluid is increasingly diverted from the bypass channel to the actuator (fine control). The spool stroke is divided into three phases: overlap (leak-free in the neutral position), fine control range (flow and pressure), residual stroke (fully open).

Due to the large fine control range of the spool stroke it is possible to sensitively control the actuators.

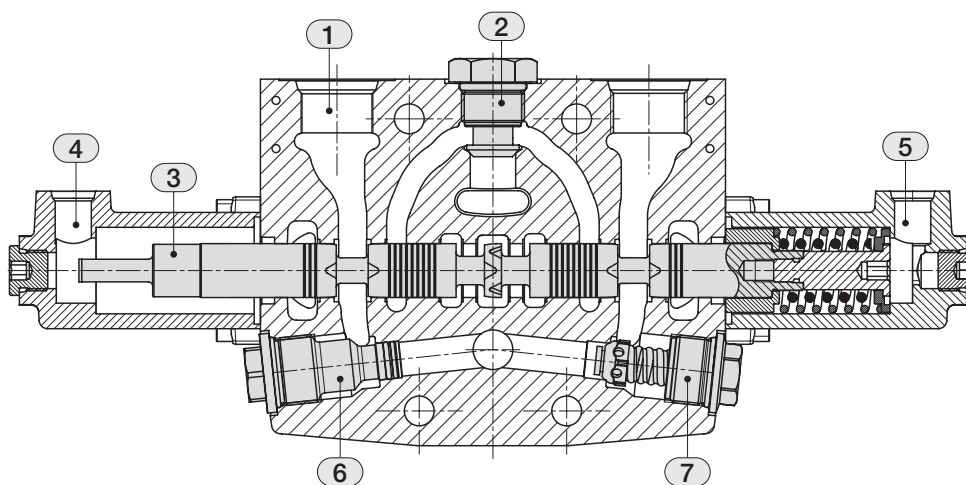

Section ECS08A with hydraulic actuation and fixed setting combined valves.



QUICK REFERENCE GUIDE

TYPE	ECS08A	ECS10A	ECS12A
Number of sections	1-12	1-12	1-12
Parallel circuit	•	•	•
Tandem circuit	•	•	•
Parallel circuit stroke (mm) - [in]	6 [0.24]	7 [0.28]	8 [0.32]
Float spool extra stroke (mm) - [in]	5 [0.20]	4.5 [0.18]	6 [0.24]
Spool pitch (mm) - [in]	36 [1.42]	41 [1.62]	48 [1.89]
Spool diameter (mm) - [in]	14 [0.55]	16 [0.63]	19 [0.75]
Nominal flow (l/min) - [GPM]	50 [12]	100 [25]	150 [40]
Operating pressure (bar) - [psi]	350 [5000]	350 [5000]	350 [5000]
OPTION CHART	ECS08A	ECS10A	ECS08A
Pilot operated pressure relief valve	•	•	•
Solenoid dump valve 12 VDC	•	•	•
Solenoid dump valve 24 VDC	•	•	•
Main anticavitation check valve	•	•	•
SPOOL ACTUATION	ECS08A	ECS10A	ECS12A
Manual actuation	•	•	•
Hydraulic actuation	•	•	•
Electrohydraulic actuation	•	•	•
SPOOL RETURN ACTION	ECS08A	ECS10A	ECS12A
3 positions spring centered	•	•	•
Pneumatic control	•	•	•
Detent in position 1/2 - 1 - 2	•	•	•
Detent in 4 th position	•	•	•
AUXILIARY VALVES	ECS08A	ECS10A	ECS12A
Fixed setting combined valve	•	•	•
Fixed setting anticavitation valve	•	•	•
Adjustable pilot combined valve		•	•

APPLICATION AND SAFETY GUIDELINES

INTENDED USE

Directional control valve ECS08A is designed for industrial use.

WARRANTY

Check the package and the product for transport damage when receiving goods. The package is not meant for long term storage; protect the product appropriately. Do not dismantle the product. The warranty is void if the product has been disassembled. The manufacturer is not responsible for damages resulting from misinterpreted, non compliance, incorrect, or improper use of the product that goes against the instructions given in this document.

GENERAL SAFETY INSTRUCTIONS

The following instructions apply to all procedures associated with the product. Read these instructions carefully and follow them closely.

- Use necessary personal protective equipment when working with the product.
- Support the product properly; make sure the product cannot fall over or turn around by accident.
- Use only appropriate equipment and attachments for lifting and transferring the product.
- Prevent unintended use of the product during installation and maintenance procedures.
- Never use the Control Valve at a pressure exceeding the rated pressure.
- Use the Control Valve within the rated flow; if not there might be malfunction or a deterioration in heat balance.
- Using low-cleanliness hydraulic fluid might cause seal failure or damage to the seal part, resulting in operation failure, or operation mistake of the machine; the customer is requested to check the cleanliness of the hydraulic fluid.

WARNING SYMBOL

The following symbols can be used in this manual:



Note:
Useful
information



Danger:
Danger of death
or injury



Attention:
May cause damage
to the product

STORAGE OF NEW PRODUCT

Encapsulated by a protective wrapping, the control valve ECS08A shall not be exposed to direct sunlight nor to source of heat or ozone and kept in a dry place at a temperature between -20°C +50°C [-4°F +122°F].

Do not store the product in:

- Places where it might be damaged;
- Very hot/humid areas;
- Where it could get wet;
- Where it could come into contact with organic solvents, acids, alkalis and/or dangerous gases;
- In places subject to sudden, significant changes in temperature.

EBI motion control is not responsible for any damages due to a storage not in compliance with our prescriptions; For any doubts, please contact our aftersales office.

SAFETY GUIDELINES

During any operation on product ECS08A, it is recommended to pay attention to components surfaces temperature. The circuit functions are to be so designed that uncontrolled machine movements, caused by the application, are prevented and that it is possible to switch from one function to another. Take into account all of the application limits, particularly those application limits stated within this technical catalogue.

It is recommended to follow these steps and only trained and competent personnel may carry out any work on ECS08A Control Valve:

- Do not direct the jet of a pressure washing unit directly to the product
- Ensure that all matching surfaces are clean, without contamination.

- Ensure that all seals and back-up rings for the matching surfaces are flawless and correctly placed.
- Do not put any sealing material other than the standard seals.
- During the assembly of the complete Control Valve, refer to the hydraulic scheme and to the name assigned to each port.
- Use gloves in order to avoid accidental injuries during installation or maintenance.
- Do not grab / handle product from moving parts (i.e. cables, levers,...etc.)
- All Control Valve are attributable to pressure vessels. It's always recommended to place the components in a closed but ventilated compartment, able to protect the environment and users in case of accidental ejection of material under pressure (fittings, pipes, plugs, expander,...etc.)
- Before removing or disassembling the complete Control Valve or allowed parts (as pressure gauge ports, plugs) it is strongly recommended to vent all hydraulic pressure from the system.
- During the first start of the machine, please ensure that the grounding system is connected and stay away from moving parts.

HANDLING PRECAUTIONS

If the Control Valve doesn't work in the adequate way, we advise you to contact our aftersales Office. However if the disassembly and assembly operations are strictly unavoidable, you must observe the following prescriptions and charge the carrying out of the operations to technicians high qualified in hydraulic field.

- The Control Valve reaches high temperature after operating the machine; start the work only after checking that the temperature is low;
- The valve can hold high internal pressure; release the inside pressure and ensure all machine actuators are in a rest position before removing the piping. In any case safely and carefully unscrew connections and fittings.
- Since hydraulic devices are all machined precisely with very accurate clearances, carry out the disassembly adassembly work at a clean place;
- Before disassembly work, get the assembly instructions by requiring to our aftersales office and prepare all the material needed for the task;
- To disassemble and assemble the valve observe strictly our mounting instructions;
- Since there is the possibility of rust when the disassembled parts are left, apply anticorrosive oil to the parts and seal them;
- Before remounting the Control Valve on the operating machine, ensure that the Control Valve has not been affected by carrying out various hydraulic tests (e.g. Relief Valve setting, Leak test..).



Attention:

Always bear in mind that "all workers must act responsibly to ensure their own health and safety"; use of personal protection equipment is therefore essential. All the disassembly and assembly operations must observe strictly the procedures listed in the EBI procedures. EBI motion control is not responsible for any damages due to disassembly and assembly procedures not in compliance with our prescriptions. For any doubts, please contact our aftersales department.

INSTALLATION PROCEDURES

On receiving the Control Valve make sure you:

- Check if there are some sign of damage of the packaging;
- Check that the dimensions of the product seat are compatible with those of the product itself;
- Remove the plastic caps that protect the service ports and be careful not to introduce any dirt or foreign matters inside the control valve as this could damage it;
- Mount the control valve securely to a flat surface (recommended 3 point fixing); at the time do not use a hammer to positioning by hitting; any distortion in assembly can result in spool sticking and poor control;
- Clean piping materials sufficiently before use;
- Prevent the port openings from being entered with dust or foreign matters;
- tighten the port connectors surely with the recommended fastening torques;
- If possible, install the valve in a protected environment, avoiding direct exposure to weathering, water, salt or any other corrosion substances.

FITTINGS TIGHTENING TORQUE (Nm)

Do not tighten fittings with torque more than the recommended value; If not there might be strains or damage to Control Valve so as to cause a serious accident.

If the pipings are not connected to the correspondent ports, unintentional movements might cause a serious accident; EBI motion control is not responsible for any damages due to an installation procedure not in compliance with our procedures.

SPECIFICATIONS	PORT (P)		PORT (A-B)	PORT (T)
BSP THREADS ISO 1179-1	G 3/8	G 1/2	G 3/8	G 1/2
<i>with rubber saling (DIN 3869)</i>	40 Nm	90 Nm	40 Nm	90 Nm
<i>with copper or steel and rubber washer</i>	40 Nm	90 Nm	40 Nm	90 Nm
UN/UNF THREADS ISO 11926-1	3/4" 16 UNF	7/8" 14 UNF	3/4" 16 UNF	7/8" 14 UNF
<i>with o-ring</i>	40 Nm	90 Nm	40 Nm	90 Nm

UNITS OF MEASURE - CONVERSION FACTORS

LENGHT	FLOW RATE	MASS	FORCE WEIGHT	PRESSURE
1 mm = 0,0394 in	1 l = 0,2200 gal UK	1 kg = 2,205 lb	1 Nm = 0,1020 Kgf	1 bar = 100000 Pa
1 in = 25,4 mm	1 l = 0,2642 gal US	1 lb = 0,4536 kg	1 Kgf = 9,8067 Nm	1 bar = 14,5 psi
	1 gal UK = 4,546 l			1 Pa = 0,0001 bar
	1 gal UK = 1,2010 gal US			1 Pa = 0,00014 psi
	1 gal US = 3,785 l			1 psi = 0,0689 bar
	1 gal US = 0,8327 gal UK			1 psi = 6890 Pa

PRODUCT IDENTIFICATION

The product identification data can be found on the identification plate attached to the EBI product.

SERIAL NUMBER

all manufacturing data and all sales data can be found with the serial number

PART NUMBER CODE

It is a number univocally identifying the configuration and pressure setting of a valve



Note:

Serial number and part number code have 9 characters (letters and numbers).

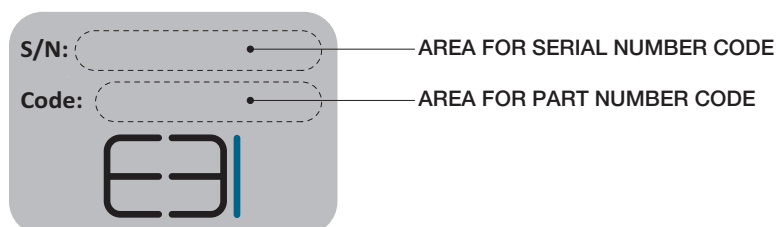

Attention:

These guidelines are not intended to be considered as complete



HYDRAULIC FLUID

Mineral oil based hydraulic fluids suitable for hydraulic systems can be used; they should have physical lubricating and chemical properties as specified by:

MINERAL OIL BASED HYDRAULIC FLUIDS HL (DIN 51524 part 1)

MINERAL OIL BASED HYDRAULIC FLUIDS HLP (DIN 51524 part 2)

For use of environmentally friendly fluids (vegetable or polyglycol base), or other fluids, please contact EBI.

OIL AND SOLUTIONS - ISO 6743/4	(°C) MIN	(°C) MAX
Mineral Oil HL, HM or HLP	-25	+80
Oil in water emulsion HFA	+5	+55
Oil in water emulsion HFB	+5	+55
Polyglycol-based aqueous solution HFC	-10	+60

Hydraulic fluids are available in different viscosity classes identified by the ISO VG number, which corresponds to the kinematic viscosity at 40°C. Here is a table showing typical viscosity changes between 0°C and 100°C for mineral oil based fluids having various viscosity classes. The fluid should be selected with the aim to achieve an appropriate operating viscosity at the expected working temperature.

VISCOSITY CLASS AND FILTRATION DATA			
Viscosity class	kinematic viscosity (cSt)		
	maximum (0° C)	medium (40° C)	minimum (100° C)
ISO VG 10	90	10	2.4
ISO VG 22	300	22	4.1
ISO VG 32	420	32	5.0
ISO VG 46	780	46	6.1
ISO VG 68	1400	68	7.8
ISO VG 100	2560	100	9.9

FLUID CLEANLINESS REQUIREMENTS

The cause of malfunctions in hydraulics is often found to be excessive fluid contamination. The hard contaminant particles in the fluid wear the hydraulic components and prevent the poppets from re-seating, with consequent internal leakage and system inefficiency. For the correct operation it is necessary to adopt filtration methods which guarantee for life the specified fluid cleanliness level. It is important to ensure that hydraulic fluids are brought to the appropriate cleanliness level prior filling up the systems, and, when in doubt, also to flush the hydraulic components prior to installation.

FILTRATION RATIO $BETA_x$:

It is the ratio between the number of particles before and after the filter with diameter larger than X micron.

ABSOLUTE FILTRATION RATIO ISO 4572:

It is the diameter X of the largest particle with $BETA_x \geq 75$.

CONTAMINATION CLASS ISO 4406:

It is expressed by 3 scale numbers representing respectively: the number of particles equal to or larger than 4µm, the number of particles equal to or larger than 6µm, the number of particles equal to or larger than 14µm contained in 1 ml of fluid.

CONTAMINATION CLASS NAS 1638:

It is expressed by one scale numbers representing the number of particles of different size ranges contained in 1 ml of fluid.

FILTRATION RECOMMENDATION				
Type	Nominal filtration (micron)	Absolute filtration rating ISO 4572 (BETA _{x≥75})	Contamination class	
			ISO 4406	NAS 1638
System/components operating at <i>HIGH PRESSURE > 250 bar</i> <i>HIGH DUTY CYCLE APPLICATIONS</i> Systems/components with <i>LOW dirt tolerance</i>	10	X = 10... 12	19/17/14	8
System/components operating at <i>MEDIUM HIGH PRESSURE</i> <i>HIGH DUTY CYCLE APPLICATIONS</i> Systems/components with <i>MODERATELY dirt tolerance</i>	15	X = 12... 15	20/18/15	9
System/components operating at <i>LOW PRESSURE < 100 bar</i> <i>LOW DUTY CYCLE APPLICATIONS</i> Systems/components with <i>GOOD dirt tolerance</i>	25	X = 15... 25	21/19/16	10



Attention:

If the filtration demands are not met, the valve poppets can jam in the open position, with the result that the valve remains actuated. It is not possible to force back jammed poppets mechanically.



PORT DETAILS

The connection port size is indicated by an ordering code common for all EBC products. Following tables show all available connections.

BSP THREADS ISO 1179-1	D	C		B		A		CODE
	UNI-ISO 228	mm	in	mm	in	mm	in	
	G 1/4	13	0.51	19	0.75	1	0.094	1B
	G 3/8	13	0.51	25	0.98	1	0.04	2B
	G 1/2	15	0.59	29	1.14	1.5	0.06	3B
	G 3/4	17	0.67	36	1.42	1.5	0.06	4B
	G 1	19	0.75	45	1.77	2	0.08	5B

UN/UNF THREADS ISO 11926-1	D	C		B	L		M		K	A		CODE	
	ASA-B1-1	mm	in	mm	in	mm	in	mm	in		mm	in	
	9/16-18 UNF (SAE6)	13	0.51	26	1.02	15.6	0.61	2.5	0.098	12°	1	0.04	1S
	3/4-16 UNF (SAE8)	15	0.59	30	1.18	20.6	0.81	2.6	0.102	15°	1.5	0.06	2S
	7/8-14 UNF (SAE10)	17	0.67	34	1.34	23.9	0.94	2.6	0.102	15°	1.5	0.06	3S
	1"1/16-12 UNF (SAE12)	20	0.79	41	1.61	29.2	1.15	3.3	0.13	15°	1.5	0.06	4S
	1"5/16-12 UNF (SAE16)	20	0.79	50	1.97	35.5	1.40	3.3	0.13	15°	2	0.08	5S

DIMENSIONS

ECS08A MECHANICAL ACTUATION

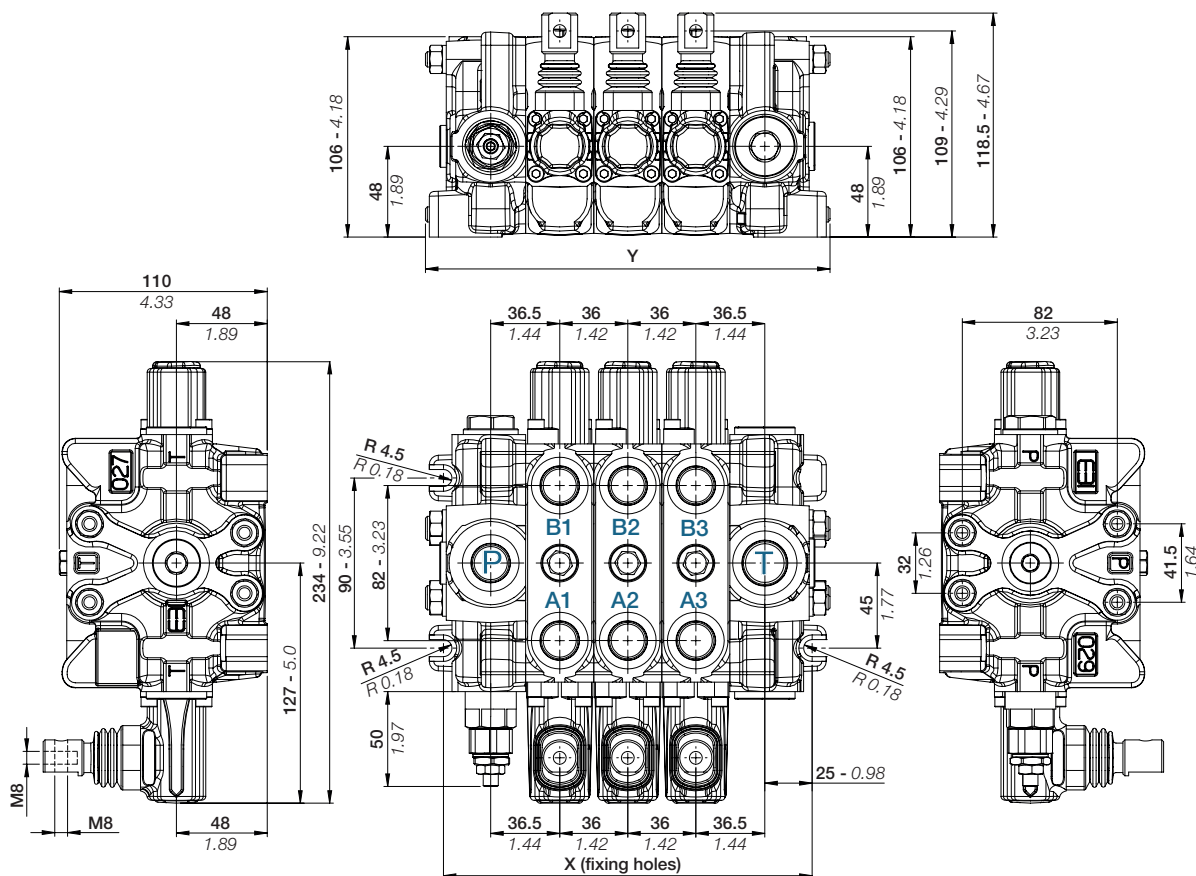

STANDARD CONNECTIONS

TYPE	BSP (ISO 1179-1)	UN-UNF (ISO 11926-1)
INLET - P	G 3/8	3/4" - 16 UNF (SAE8)
gauge connection	G 1/4	9/16" - 18 UNF (SAE6)
PORTS - A/B	G 3/8	3/4" - 16 UNF (SAE8)
OUTLET - T/T1	G 1/2	7/8" - 14 UNF (SAE10)
Pneumatic pilot	G 1/8	NPTF 1/8-27

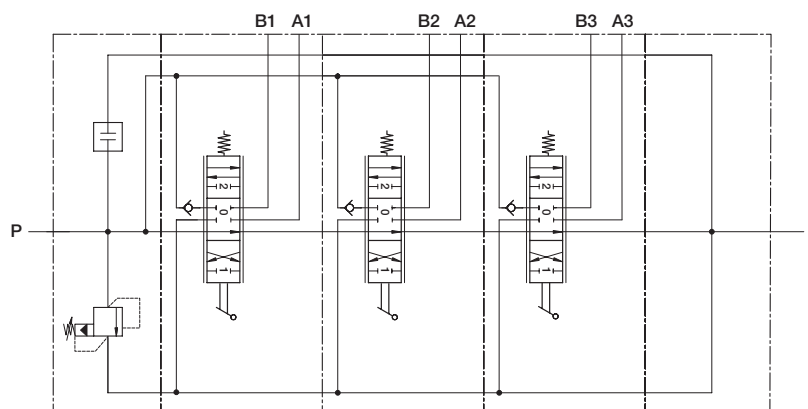



DIMENSIONS

ECS08A HYDRAULIC ACTUATION

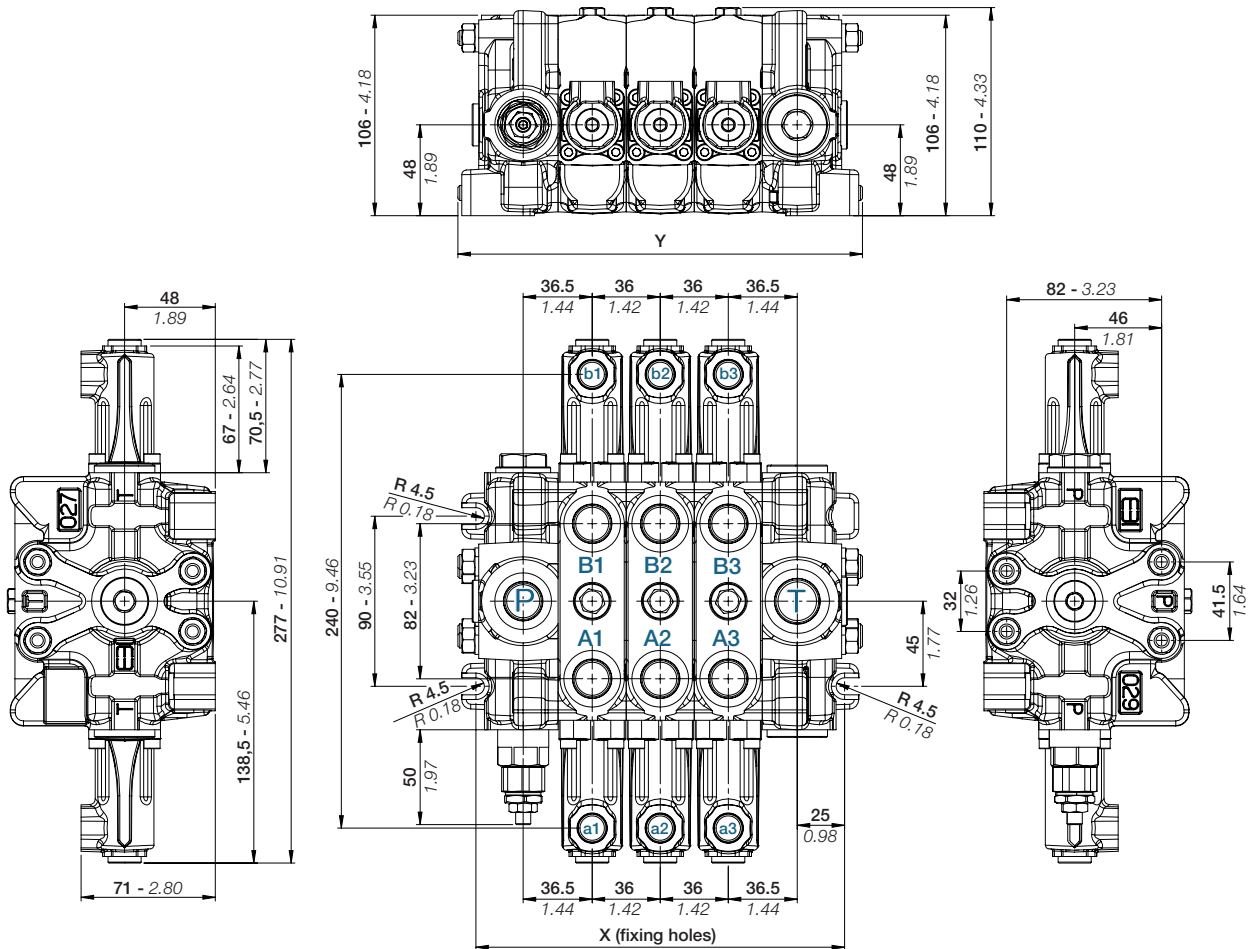

STANDARD CONNECTIONS

TYPE	BSP (ISO 1179-1)	UN-UNF (ISO 11926-1)
INLET - P	G 3/8	3/4" - 16 UNF (SAE8)
gauge connection	G 1/4	9/16" - 18 UNF (SAE6)
PORTS - A/B	G 3/8	3/4" - 16 UNF (SAE8)
OUTLET - T/T1	G 1/2	7/8" - 14 UNF (SAE10)
hydraulic pilot (a-b)	G 1/4	9/16" - 18 UNF (SAE6)

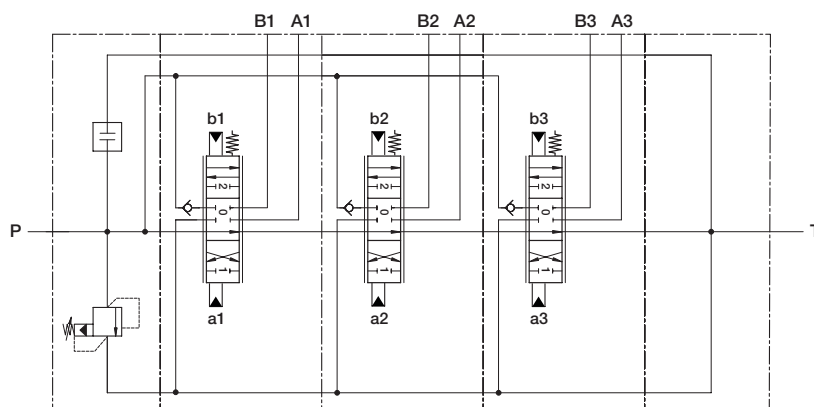

DIMENSIONS

ECS08A ELECTROHYDRAULIC ACTUATION

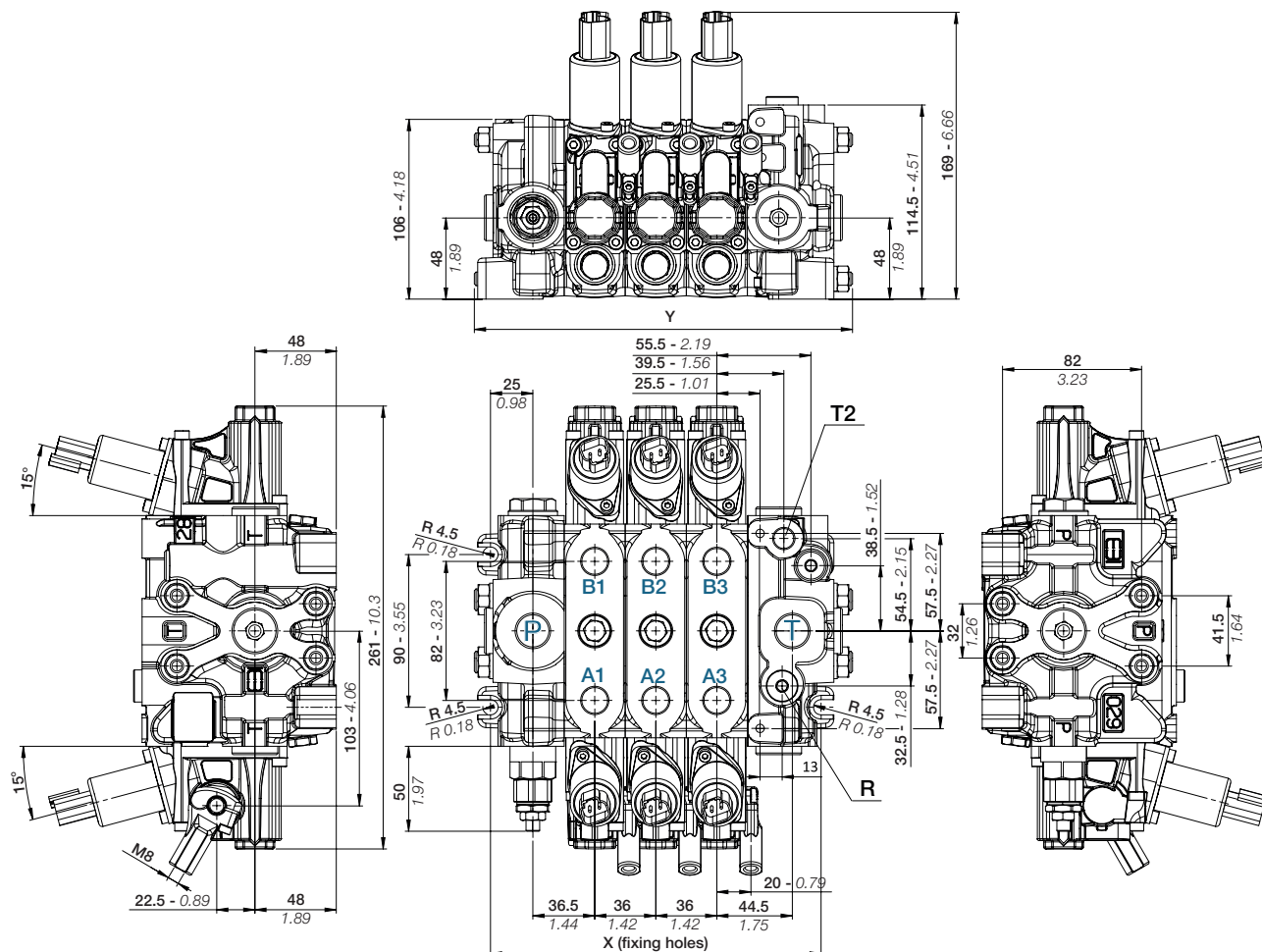

STANDARD CONNECTIONS

TYPE	BSP (ISO 1179-1)	UN-UNF (ISO 11926-1)
INLET - P	G 3/8	3/4" - 16 UNF (SAE8)
gauge connection	G 1/4	9/16" - 18 UNF (SAE6)
PORTS - A/B	G 3/8	3/4" - 16 UNF (SAE8)
OUTLET - T/T1	G 1/2	7/8" - 14 UNF (SAE10)



Note:

All outlet sections ECS08A for electrohydraulic configuration contain a pressure reducing valve (RDP).

We recommend to connect drain port T2 directly to tank, in order to avoid control system damages and inaccurate control.

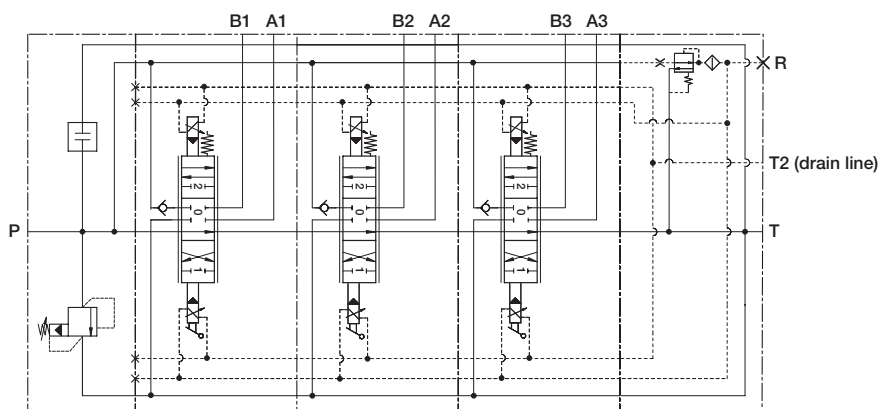



TECHNICAL SPECIFICATIONS

TYPE	X	Y (mechanical version)	Y (electrohydraulic version)	WEIGHT (mechanical version)	WEIGHT (electrohydraulic version)
	mm - [in]	mm - [in]	mm - [in]	kg - [lb]	kg - [lb]
ECS08A/1	123 - [4.85]	142 mm - [5.595]	151 mm - [5.949]	8,6 - [19]	9,2 - [20.3]
ECS08A/2	159 - [6.26]	178 mm - [7.013]	187 mm - [7.368]	11,6 - [25.6]	12,2 - [26.9]
ECS08A/3	195 - [7.68]	214 mm - [8.432]	223 mm - [8.786]	14,6 - [32.2]	15,2 - [33.5]
ECS08A/4	231 - [9.10]	250 mm - [9.850]	259 mm - [10.205]	17,6 - [38.8]	18,2 - [40.1]
ECS08A/5	267 - [10.52]	286 mm - [11.268]	295 mm - [11.623]	20,6 - [45.4]	21,2 - [46.7]
ECS08A/6	303 - [11.94]	322 mm - [12.687]	331 mm - [13.041]	23,6 - [52]	24,2 - [53.3]
ECS08A/7	339 - [13.36]	358 mm - [14.105]	367 mm - [14.460]	26,6 - [58.6]	27,2 - [60]
ECS08A/8	411 - [16.19]	394 mm - [15.524]	403 mm - [15.878]	29,6 - [65.3]	30,2 - [66.6]
ECS08A/9	447 - [17.61]	430 mm - [16.942]	439 mm - [17.297]	32,6 - [71.9]	33,2 - [73.2]
ECS08A/10	483 - [19.03]	466 mm - [18.360]	475 mm - [18.715]	35,6 - [78.5]	36,2 - [79.8]
ECS08A/11	519 - [20.45]	502 mm - [19.779]	511 mm - [20.133]	38,6 - [85.1]	39,2 - [86.4]
ECS08A/12	555 - [21.87]	538 mm - [21.197]	547 mm - [21.552]	41,6 - [91.7]	42,2 - [93]

TECHNICAL DATA

All performances in this catalogue are obtained using mineral based hydraulic oil 46 cSt viscosity at 40°C (ISO VG 46 viscosity class). All ECS08A go through functional testing at these conditions before shipment.

HYDRAULIC STANDARD SPECIFICATIONS

Nominal Flow range	50 l/min - [12 GPM]
Nominal pressure	350 bar - [5000 psi]
Hysteresis	< 1 bar - [14,5 psi]
Hydraulic fluid	Mineral Oil HL, HLP (DIN 51524); phosphate ester (HFD-R)
Fluid temperature range	-20°C +80°C [-4°F +176°F]
Fluid viscosity range	10 ÷ 380 cSt
Max contamination level	9 (NAS 1638) - 20/18/15 (ISO 4406:1999)
Recommended filtration	B10 > 75 (ISO 16889:20008)

MECHANICAL STANDARD SPECIFICATIONS

Spool return force (without detent)	90 ÷ 125 N (std spring)
Max actuation force on the spool (radial)	16 N

GENERAL STANDARD SPECIFICATIONS

Weight (inlet section)	2,8 Kg - [6,2 lb]
Weight (work section)	3 Kg - [6,6 lb]
Weight (outlet section)	2,8 Kg - [6,2 lb]
Weight (outlet section with reducing valve)	3,4 Kg - [7,5 lb]
Max number of sections	12

MATERIAL STANDARD SPECIFICATIONS SEALS

O-Rings: **Buna N** (acrylonitrile butadiene), also named **NBR** (according to ASTM), compatible with fluids having mineral oil base, water in oil emulsions, and water glycol fluids.

These seals are standard for temperatures within the range -20°C and +80°C

Back-up rings and Slide rings: **strengthened PTFE** (Politetrafluoroetilene like Teflon®, Lubriflon®, Ecoflon®, or similar). Special FPM (Viton®) seals are available on request.

Note: the seal materials are compatible with the fluids normally used in hydraulic systems; in case of special fluids, if you suspect incompatibility between the fluid used and the standard seals, contact the EBC motion controls service network.

TYPICAL CURVES

PERFORMANCE DATA - PRESSURE DROP (P-T)

Pressure characteristic as function of flow

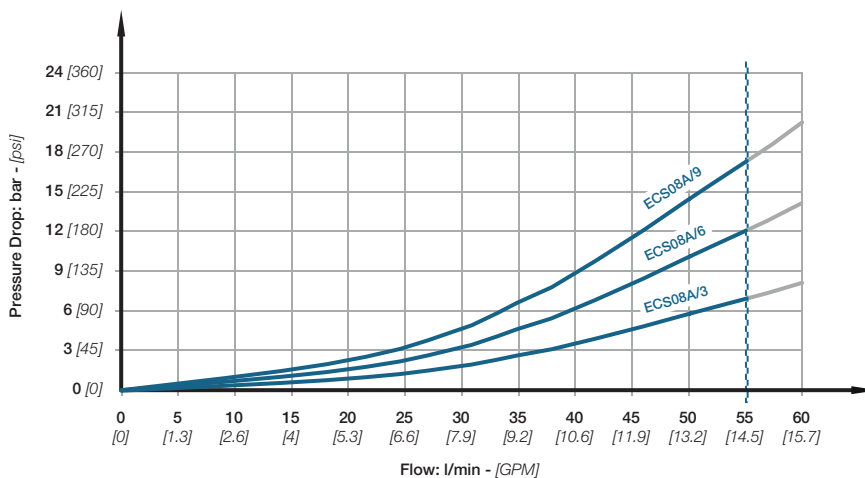

PERFORMANCE DATA - PRESSURE DROP (P-A/B)

Pressure characteristic as function of flow

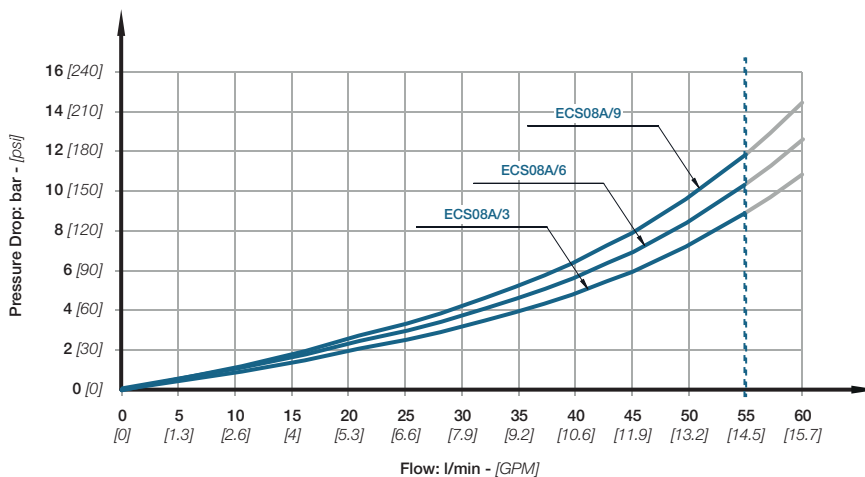

PERFORMANCE DATA - PRESSURE DROP (A/B-T)

Pressure characteristic as function of flow

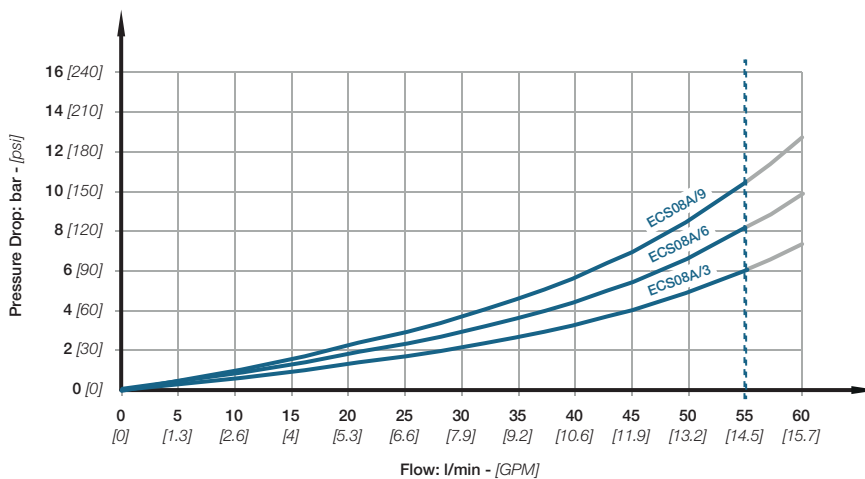

CIRCUITS

PARALLEL CIRCUIT: a number of actuators can be operated simultaneously

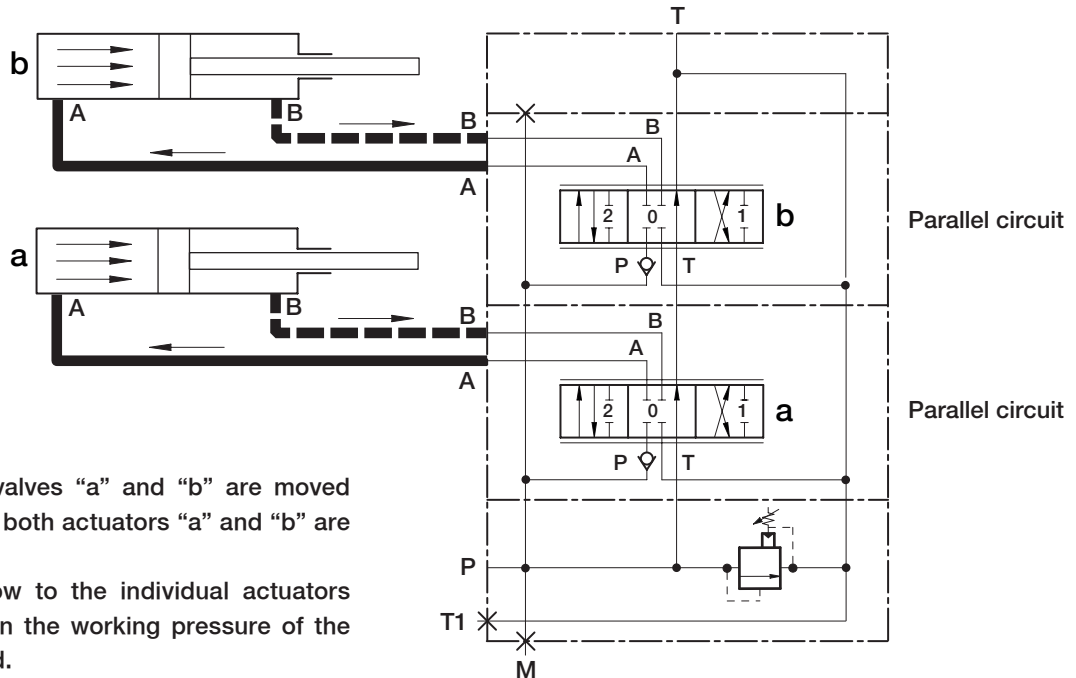

Example:

When directional valves “a” and “b” are moved to position 2 (or 1), both actuators “a” and “b” are operated.

The division of flow to the individual actuators is dependent up on the working pressure of the actuator concerned.

TANDEM CIRCUIT: only one actuator may be operated.

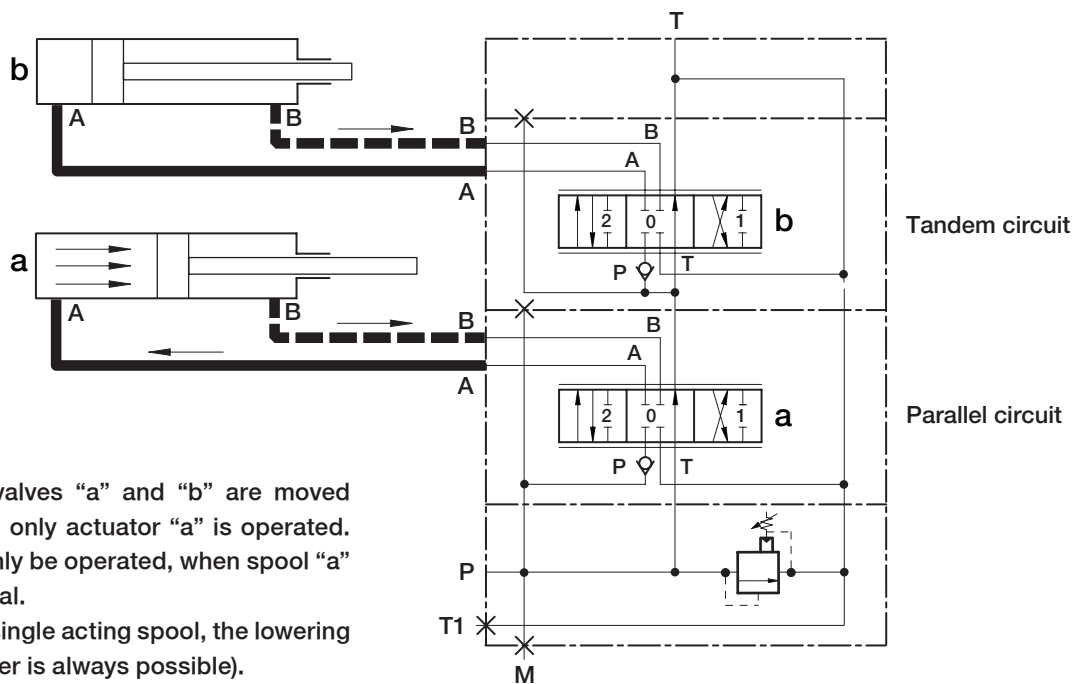

Example:

When directional valves “a” and “b” are moved to position 2 (or 1), only actuator “a” is operated. Actuator “b” can only be operated, when spool “a” is returned to neutral.

(Exception: with a single acting spool, the lowering action of the cylinder is always possible).

ORDERING CODES

The order code below provides an example of control ECS08A with standard configuration.

This example represents a ECS08A with single electrohydraulic section.

You can configure a ECS08A up to 12 work sections; ordering code in position 6, 7, 8, 9, 10, 11, 12 and 13 must be repeated for every work section.

info	product						1																												
	E	C	S	0	8	A	N	1	E																										
inlet section	2	3			4				5																										
	L	P	1	2	S	V	0	1	1	5	0	V	0	2																					
Work section	6	7				8			9		10		11		12		13																		
	L	S	1	P	2	E	2	S	V	5	1	1	0	0	V	5	1	1	8	0	S	0	1	N	A	E	0	1	R	E	0	1	K	1	2
outlet section	14	15																																	
	L	T	1	R	3	S																													
options	16																																		
	X	1																																	

	POSITION	CODE	DESCRIPTION	PAGE
info		ECS08A	Product	
	1	N1E	Assembly section	22
Inlet section	2	L	Inlet side	23
	3	P12S	Arrangement body inlet	24
	4	V01150	Inlet valve on port 1	25
	5	V02	Inlet valve on port 2	
	6	L	Section side	27
work section	7	S1P2E2S	Arrangement body section	28
	8	V51100	Valve on port A	31
	9	V51180	Valve on port B	
	10	S01N	Spool	32
	11	AE01	Actuation kit	33
	12	RE01	Return action kit	36
	13	K12D	Solenoid kit	38
outlet section	14	L	Outlet side	39
	15	T1R3S	Arrangement body outlet	40
options	16	X1	Painted option	43



Note:

Ordering codes in position 2, 6 and 14 are always the same. Indicate the mounting side of the valve.



All sectional ECS08A valves have symmetric bodies; thanks to this characteristic, it is possible to change the control side, by simply reversing the spool 180°.
All valves can easily be changed from right inlet (R) to left inlet (L) and vice versa.
This example represents a valve in left configuration.

COMPLETE SECTIONAL VALVE ECS08A

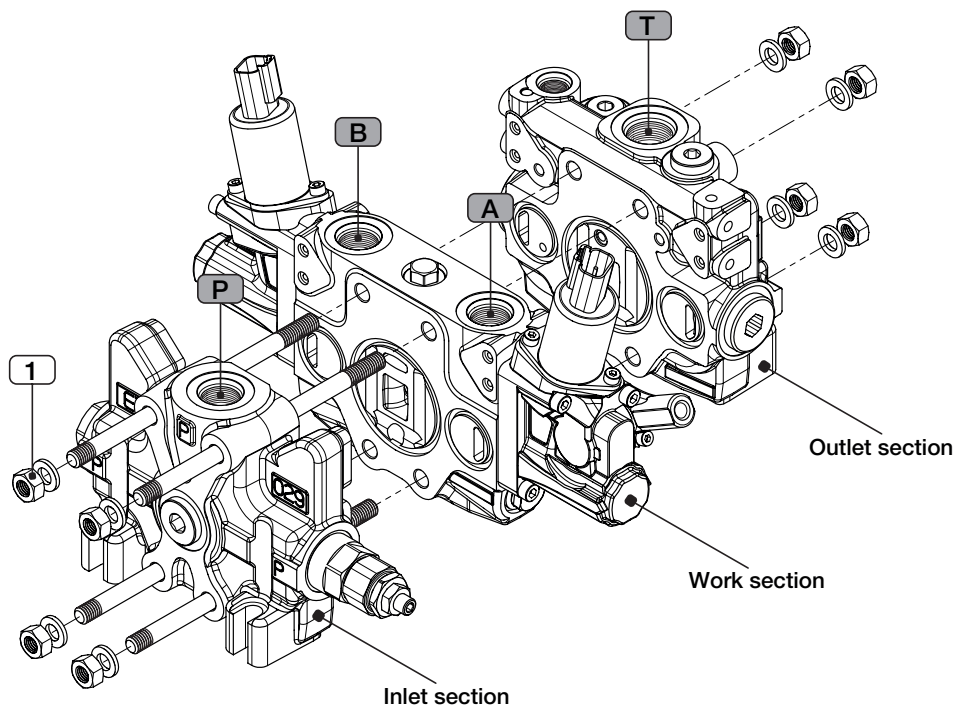

INLET SECTION

WORK SECTION

OUTLET SECTION

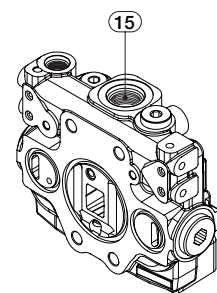
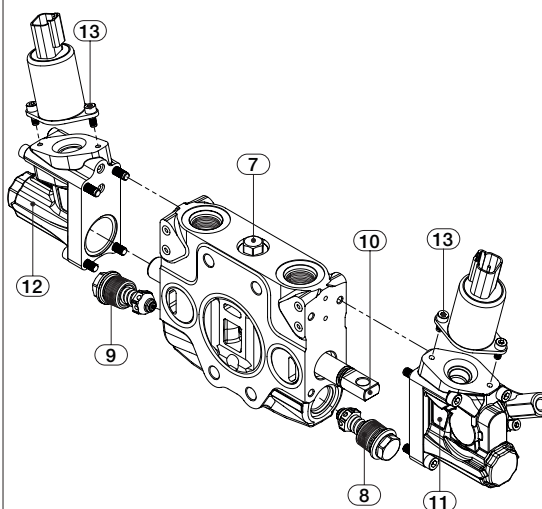
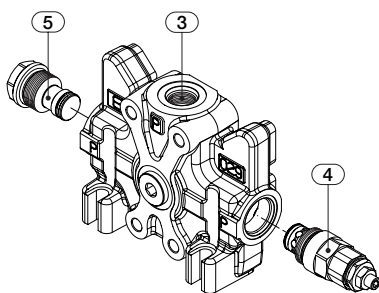

ASSEMBLY MODALITY FOR DIRECTIONAL CONTROL VALVE



Attention:

in the case of mixed configurations (section with electrohydraulic actuation and sections with mechanical or hydraulic actuation) it is mandatory to place all the electrohydraulic sections near to the outlet section. As a consequence all the mechanical or hydraulic sections will be positioned immediately after the inlet section.

EXAMPLE OF CONFIGURATION:

ECS08A/6 with 3 mechanical section and 3 electrohydraulic section: directional control valve with left inlet

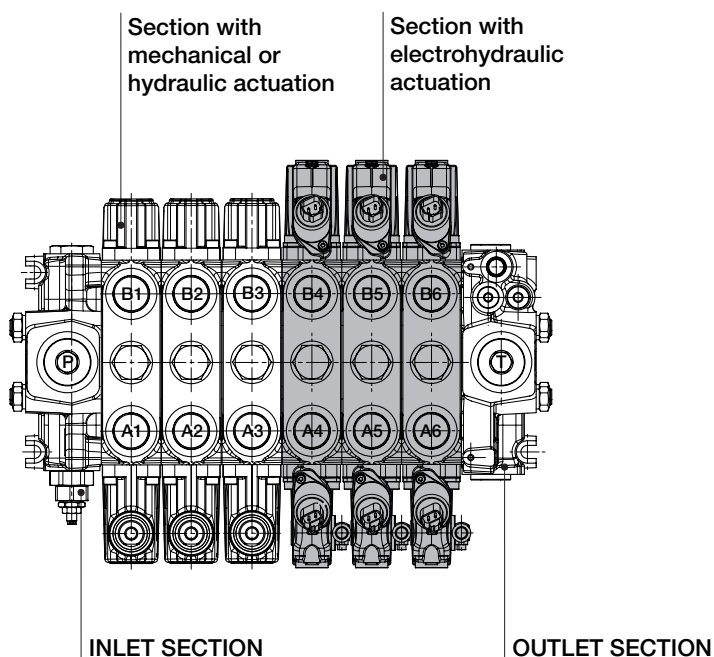

Note:

All mixed configurations are assembly with outlet section with RDP valve. Assembly modality also applies to directional control valve with right inlet.



Note:

For mixed configurations different from example, please contact our Sales Office.

ASSEMBLY SECTION

product						1
E	C	S	0	8	A	N 1 E

Tie rod kit allows the correct assembly of directional sectional valves ECS08A. Tie rod's length depends on the number of sections; each valve is assembled with tie rod kits including a tie rod, two nuts and two washer.

Two types of tie-rod kits are available:

- Assembly tie-rod for control valve with manual actuation
- assembly tie-rod for control valve with electrohydraulic actuation

DESCRIPTION	Manual actuation		Electrohydraulic actuation		CLAMPING TORQUE
	CODE	LENGHT	CODE	LENGHT	
Tie rod kit for single work section	N1M	142 mm - 5.595 in	N1E	151 mm - 5.949 in	35 Nm
Tie rod kit for 2 work sections	N2M	178 mm - 7.013 in	N2E	187 mm - 7.368 in	
Tie rod kit for 3 work sections	N3M	214 mm - 8.432 in	N3E	223 mm - 8.786 in	
Tie rod kit for 4 work sections	N4M	250 mm - 9.850 in	N4E	259 mm - 10.205 in	
Tie rod kit for 5 work sections	N5M	286 mm - 11.268 in	N5E	295 mm - 11.623 in	
Tie rod kit for 6 work sections	N6M	322 mm - 12.687 in	N6E	331 mm - 13.041 in	
Tie rod kit for 7 work sections	N7M	358 mm - 14.105 in	N7E	367 mm - 14.460 in	
Tie rod kit for 8 work sections	N8M	394 mm - 15.524 in	N8E	403 mm - 15.878 in	
Tie rod kit for 9 work sections	N9M	430 mm - 16.942 in	N9E	439 mm - 17.297 in	
Tie rod kit for 10 work sections	N10M	466 mm - 18.360 in	N10E	475 mm - 18.715 in	
Tie rod kit for 11 work sections	N11M	502 mm - 19.779 in	N11E	511 mm - 20.133 in	
Tie rod kit for 12 work sections	N12M	538 mm - 21.197 in	N12E	547 mm - 21.552 in	

This example represents ECS08A with one single work section; tie rod kit **N1E**.



Note:

Each ECS08A assembly with n.4 tie rod kit.

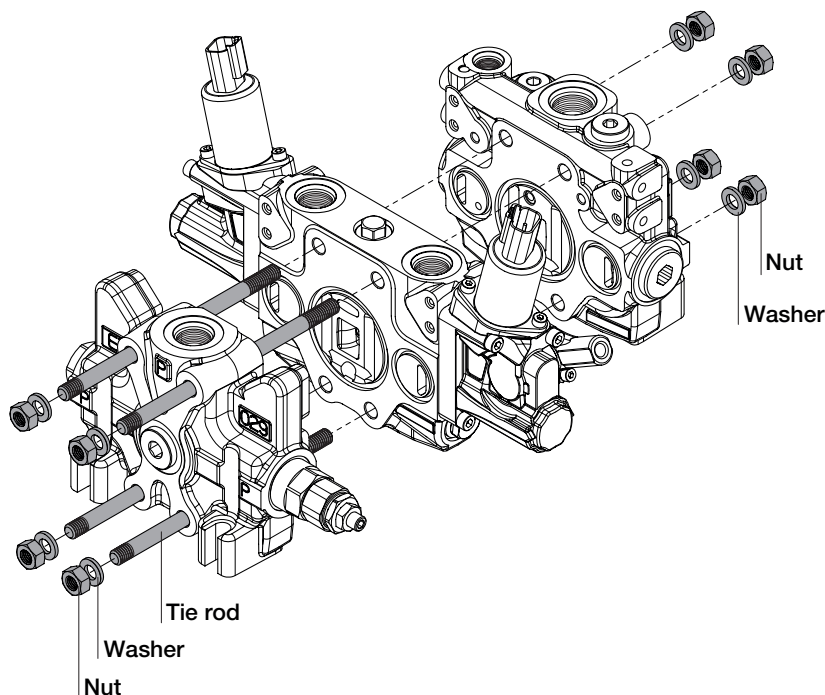

INLET SECTION

2	3			4					5				
L	P	1	2	S	V	0	1	1	5	0	V	0	2

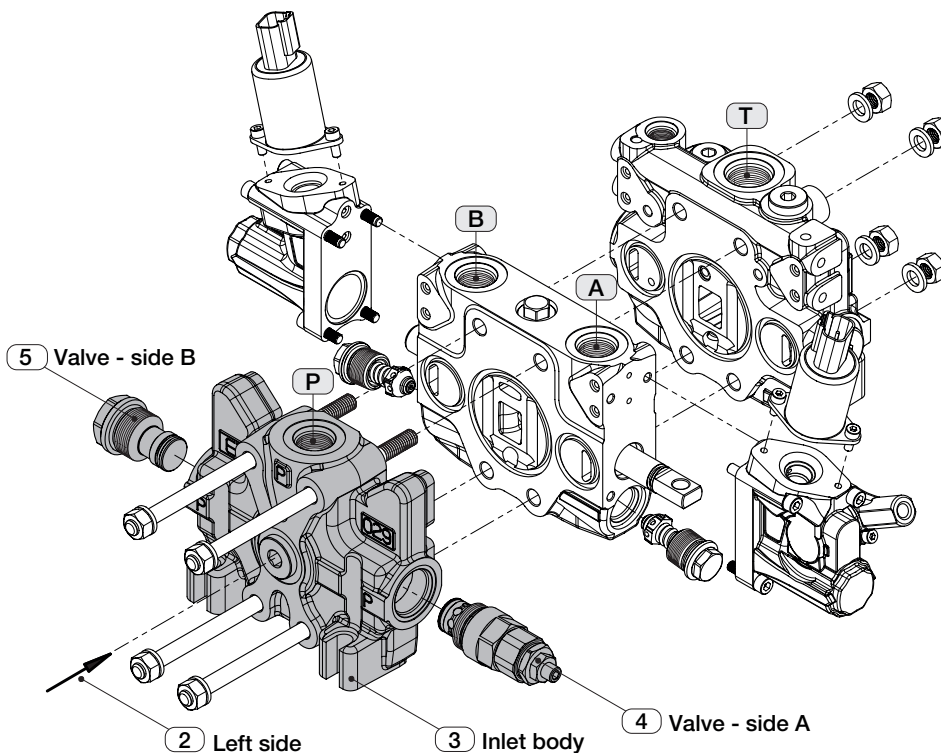

This example represents inlet section ECS08A with left configuration.

- L**.....left inlet side
- P12S**.....Upper inlet 3/4"-16 UNF (SAE8)
- V01150**.....Pilot operated pressure relief valve (150 bar) - side A
- V02**.....Relief valve plugged - side B

INLET SIDE

On all sectional ECS08A valves it is possible to choose a RIGHT or LEFT inlet.

CODE	DESCRIPTION	DRAWING	CODE	DESCRIPTION	DRAWING
L	Inlet side LEFT		R	Inlet side RIGHT	

Convention for all ECS08A valves with inlet right (R) or left inlet (L):

- side A = spool actuation side
- side B = spool return action side.

INLET SECTION

2	3				4					5			
L	P	1	2	S	V	0	1	1	5	0	V	0	2

ARRANGEMENT INLET BODY

ECS08A arrangement body inlet is available in two configurations: SAE thread or BSP thread.

The maximum flexibility of the inlet body configuration is guaranteed by the positioning of the service ports plug.

This table represents arrangement inlet body in left configuration.

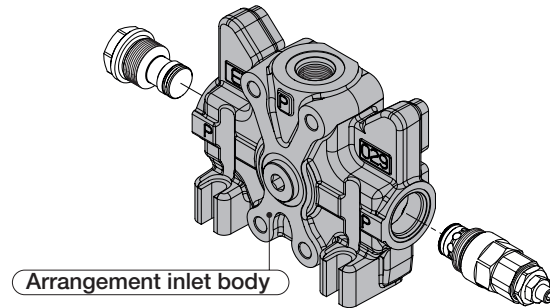

CODE	DESCRIPTION	CONFIGURATION
P12S	Upper inlet - 3/4"- 16 UNF (SAE8)	
P12B	Upper inlet - G 3/8	
P22S	Central inlet - 3/4"- 16 UNF (SAE8)	
P22B	Central inlet - G 3/8	
P32S	Upper inlet - 3/4"- 16 UNF (SAE8) with (P1) gauge connection SAE6	<p style="font-size: small;">Gauge connection: port SAE6 or G1/4</p>
P32B	Upper inlet - G 3/8 with (P1) gauge connection G 1/4	
P42S	Central inlet - 3/4"- 16 UNF (SAE8) with (P1) gauge connection SAE6	<p style="font-size: small;">Gauge connection: port SAE6 or G1/4</p>
P42B	Central inlet - G 3/8 with (P1) gauge connection G 1/4	

INLET SECTION

2	3				4					5			
L	P	1	2	S	V	0	1	1	5	0	V	0	2

INLET VALVE CLASSIFICATION

All inlet section require double choice on side A and side B; in the following table the available valves are shown.

- Valve type V01 requires factory setting (V01150); 150 is a value expressed in bar
- Valve type V04 includes coil kit
- 3 coil types are available in 12 and 24 Volt versions: DIN, DEUTSCH DT04 and AMP JUNIOR

CODE	DESCRIPTION	SYMBOL
V01	Pilot operated pressure relief valve	
V02	Relief valve plugged	
V0412A	Solenoid dump valve 12 VDC - AMP Junior	
V0424A	Solenoid dump valve 24 VDC - AMP Junior	
V0412D	Solenoid dump valve 12 VDC - DT04 Deutsch	
V0424D	Solenoid dump valve 24 VDC - DT04 Deutsch	
V0412H	Solenoid dump valve 12 VDC - DIN 43650	All solenoids dump valves are fitted with push and twist override
V0424H	Solenoid dump valve 24 VDC - DIN 43650	
V05	Externally piloted dump valve	
V06	Main anticavitation check valve	

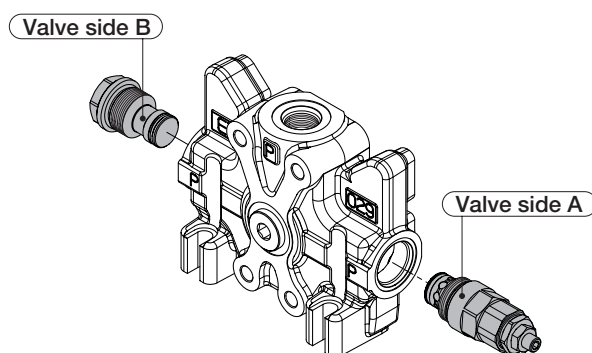

The example represents inlet section in left configuration; valve V01150 type on side A and valve V02 type on side B

- Valve side A = spool actuation side
- Valve side B = spool return action side

SETTING RANGE

Pilot operate pressure relief valve (V01): 50/350 bar

In the following table the available valve combinations are shown.

valve combination	VALVE PORT B									
	V01	V02	V0412A	V0424A	V0412D	V0424D	V0412H	V0424H	V05	V06
V01		•	•	•	•	•	•	•	•	•
V02	•	•	•	•	•	•	•	•	•	•
V0412A	•	•								•
V0424A	•	•								•
V0412D	•	•								•
V0424D	•	•								•
V0412H	•	•								•
V0424H	•	•								•
V05	•	•								
V06	•	•	•	•	•	•	•	•	•	



INLET SECTION

PERFORMANCE DATA - PILOT OPERATED PRESSURE RELIEF VALVE (V01)

Pressure characteristic as function of flow

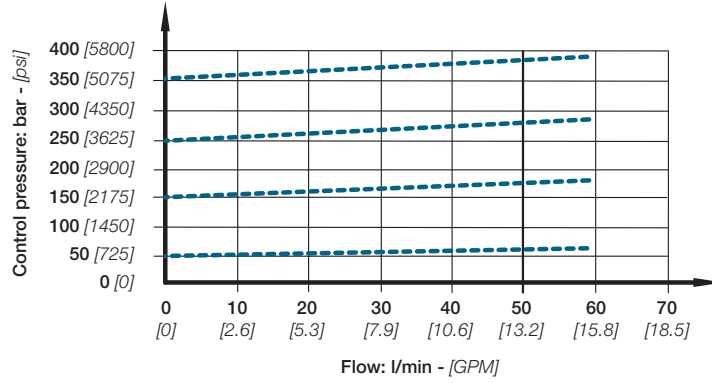

PERFORMANCE DATA - MAIN ANTICAVITATION CHECK VALVE (V06)

Pressure characteristic as function of flow

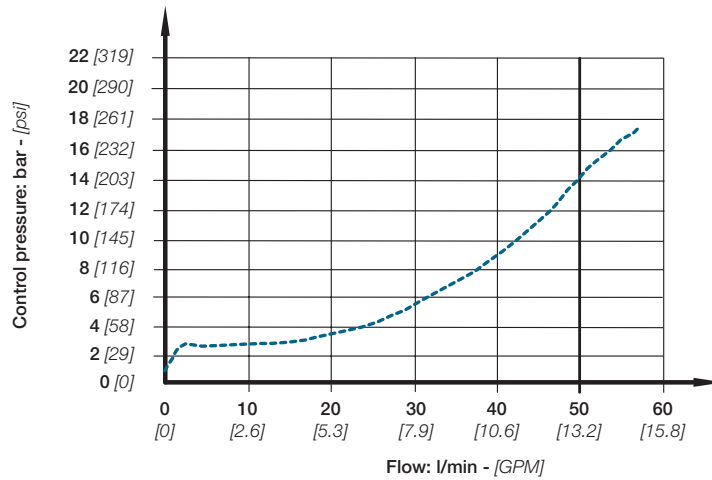

WORK SECTION

6	7					8					9					10			11			12			13										
L	S	1	P	2	E	2	S	V	5	1	1	0	0	V	5	1	1	8	0	S	0	1	N	A	E	0	1	R	E	0	1	K	1	2	D

This code indicates the complete working section set up; arrangement body, auxiliary valves, spool, actuation type and return action type.

- Should you order the working section only, you must specify the entry side: right (R) or left (L)
- Leave out the spool return action code when choosing hydraulic actuation "AH"
- Sections designed to house auxiliary valve option required double choice on work ports A and B
- Connector kit must be ordered separately with all electrohydraulic actuations; 2 coil kit each work section.

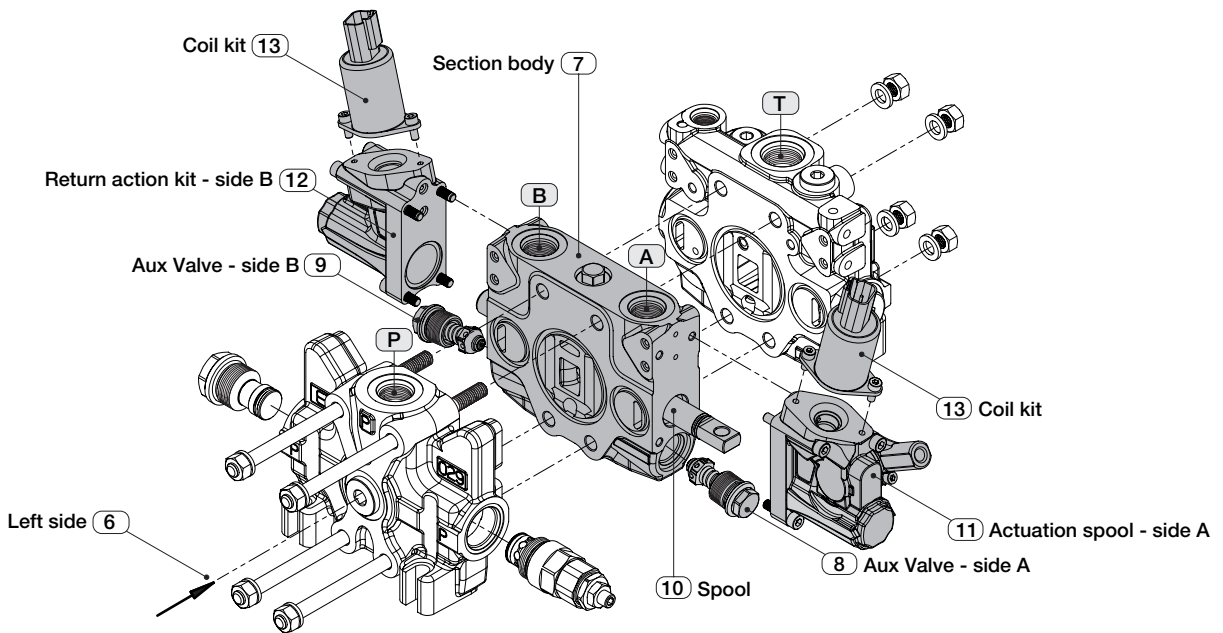

This example represents work section ECS08A with left configuration:

- L**Left side
- S1P2E2S**Parallel section with fixed valves - ports 3/4" 16 UNF (SAE8)
- V51100**Fixed setting combined valve (100 bar) - port A
- V51180**Fixed setting combined valve (180 bar) - port B
- S01N**Spool 3 positions double-acting (150 l/min)
- AE01**Electrohydraulic actuation with lever control - side A
- RE01**Electrohydraulic control return action - side B
- K12D**Connector coil kit - 12 VDC Deutsch DT04

CODE	DESCRIPTION	DRAWING	CODE	DESCRIPTION	DRAWING
L	Inlet side LEFT		R	Inlet side RIGHT	

Convention for all ECS08A valves with inlet right (R) or left inlet (L):

- side A = spool actuation side
- side B = spool return action side.

WORK SECTION

6	7	8	9	10	11	12	13
L	S 1 P 2 E 2 S	V 5 1 1 0 0	V 5 1 1 8 0	S 0 1 N	A E 0 1	R E 0 1	K 1 2 D

ARRANGEMENT SECTION BODY

ECS08A arrangement section is available in two configurations: SAE thread or BSP thread.

Work section is available with parallel circuit or tandem circuit.

There are two types of arrangement section body:

- Body for electrohydraulic actuation
- Body for mechanical or hydraulic actuation.

Each arrangement section contains:

- Body
- Check valve
- Gasket kit.

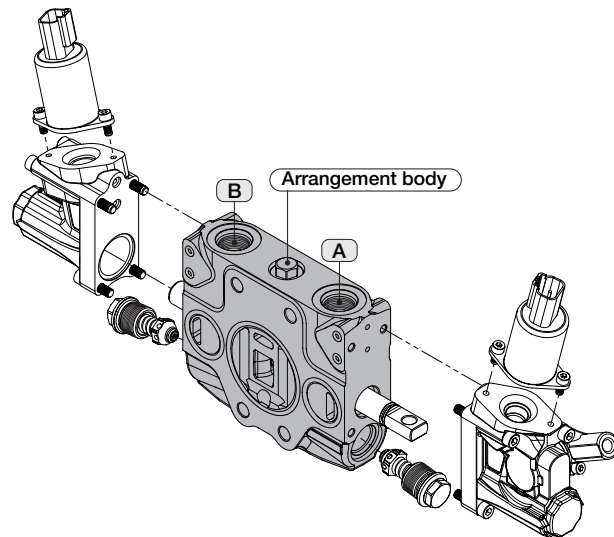

The Gasket kit allows the correct coupling between the surfaces of the working sections. The gasket kit changes according to the type of the working section; the number and type of gaskets is different between a mechanically operated section and a section with an electrohydraulic control (see the following table).

GASKET KIT FOR ELECTROHYDRAULIC SECTION

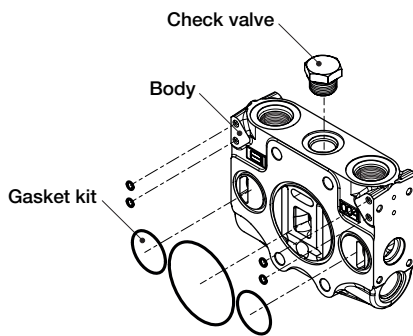

GASKET KIT FOR MECHANICAL OR HYDRAULIC SECTION

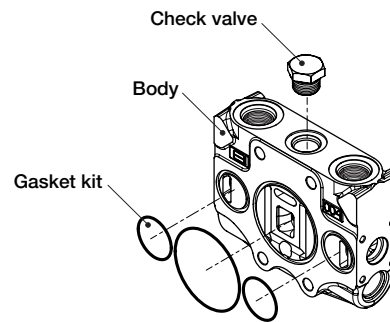

Each work section can be ordered with or without auxiliary valves; in the following table the two different sections are shown.

ARRANGEMENT SECTION BODY WITH AUXILIARY VALVES

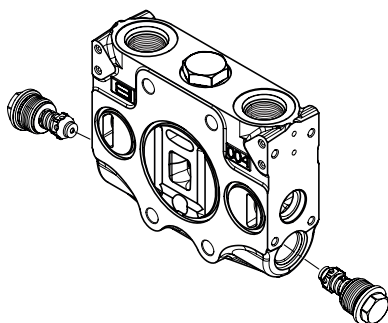

ARRANGEMENT SECTION BODY WITHOUT AUXILIARY VALVES

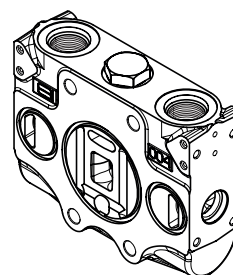

WORK SECTION

ARRANGEMENT BODY FOR MECHANICAL OR HYDRAULIC ACTUATION (PARALLEL CIRCUIT)

CODE	DESCRIPTION	CONFIGURATION
S1P2M2S	PARALLEL section with fixed valves ports 3/4"-16 UNF (SAE8)	
S1P2M2B	PARALLEL section with fixed valves ports G 3/8	
S2P1M2S	PARALLEL section without valves ports 3/4"-16 UNF (SAE8)	
S2P1M2B	PARALLEL section without valves ports G 3/8	

ARRANGEMENT BODY FOR MECHANICAL OR HYDRAULIC ACTUATION (TANDEM CIRCUIT)

CODE	DESCRIPTION	CONFIGURATION
S1T2M2S	TANDEM section with fixed valves ports 3/4"-16 UNF (SAE8)	
S1T2M2B	TANDEM section with fixed valves ports G 3/8	
S2T1M2S	TANDEM section without valves ports 3/4"-16 UNF (SAE8)	
S2T1M2B	TANDEM section without valves ports G 3/8	

WORK SECTION

ARRANGEMENT BODY FOR ELECTROHYDRAULIC ACTUATION (PARALLEL CIRCUIT)

CODE	DESCRIPTION	CONFIGURATION
S1P2E2S	PARALLEL section with fixed valves ports 3/4"-16 UNF (SAE8)	
S1P2E2B	PARALLEL section with fixed valves ports G 3/8	
S2P1E2S	PARALLEL section without valves ports 3/4"-16 UNF (SAE8)	
S2P1E2B	PARALLEL section without valves ports G 3/8	

ARRANGEMENT BODY FOR ELECTROHYDRAULIC ACTUATION (TANDEM CIRCUIT)

CODE	DESCRIPTION	CONFIGURATION
S1T2E2S	TANDEM section with fixed valves ports 3/4"-16 UNF (SAE8)	
S1T2E2B	TANDEM section with fixed valves ports G 3/8	
S2T1E2S	TANDEM section without valves ports 3/4"-16 UNF (SAE8)	
S2T1E2B	TANDEM section without valves ports G 3/8	

WORK SECTION

**ARRANGEMENT BODY FOR MECHANICAL OR HYDRAULIC ACTUATION (PARALLEL CIRCUIT)
 - ONLY FOR SECTION WITH S05 SPOOL TYPE -**

CODE	DESCRIPTION
SF1P2M2S	PARALLEL section with fixed valves - ports 3/4"-16 UNF (SAE8)
SF1P2M2B	PARALLEL section with fixed valves - ports G 3/8

**ARRANGEMENT BODY FOR ELECTROHYDRAULIC ACTUATION (PARALLEL CIRCUIT)
 - ONLY FOR SECTION WITH S05 SPOOL TYPE -**

CODE	DESCRIPTION
SF1P2E2S	PARALLEL section with fixed valves - 3/4"-16 UNF (SAE8)
SF1P2E2B	PARALLEL section with fixed valves - ports G 3/8

WORK SECTION

6	7					8					9					10			11			12			13										
L	S	1	P	2	E	2	S	V	5	1	1	0	0	V	5	1	1	8	0	S	0	1	N	A	E	0	1	R	E	0	1	K	1	2	D

AUXILIARY VALVES

ECS08A sections with auxiliary valves require double choice on work side A and side B.

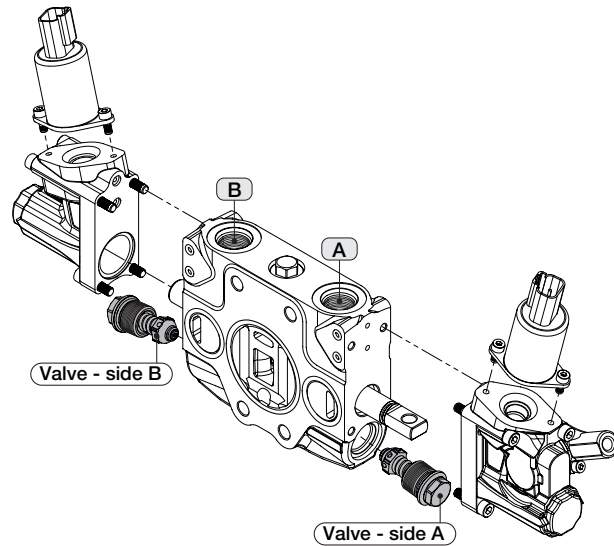

CODE	DESCRIPTION	SYMBOL	SETTING
V51	Fixed setting combined valve		50 - 350 bar
V52	Fixed setting valve plugged		
V53	Fixed setting anticavitation valve		
V59	Fixed setting Adjustable combined valve <i>(fit into fixed valve cavity)</i>		50 - 350 bar

Valves type V51 and V59 require factory setting:

V51100: 100 = value expressed in bar
factory setting is available from 50 to 350 bar with 10 bar steps.

V59100: 100 = value expressed in bar
factory setting is available from 50 to 350 bar with 10 bar steps.

Fixed setting combined valve (V51)
Pressure characteristic as function of flow

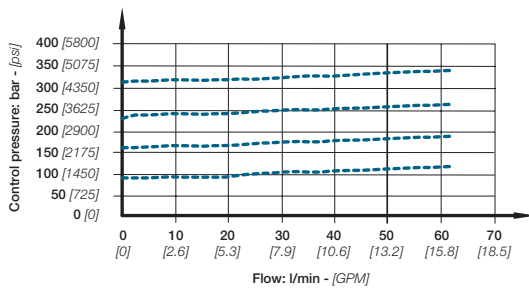

Fixed setting anticavitation valve (V53)
Pressure characteristic as function of flow

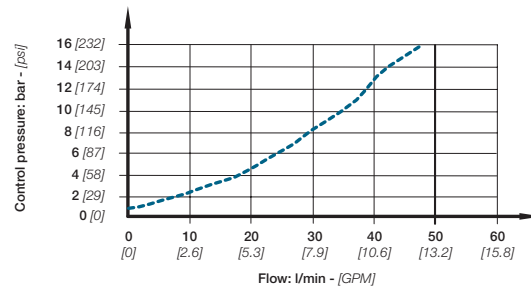

Fixed setting combined valve (V59)
Pressure characteristic as function of flow

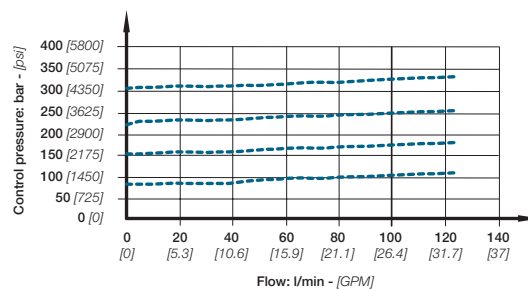

WORK SECTION

6	7	8	9	10	11	12	13
L	S 1 P 2 E 2 S	V 5 1 1 0 0	V 5 1 1 8 0	S 0 1 N	A E 0 1	R E 0 1	K 1 2 D

SPOOL CLASSIFICATION

Each ECS08A section contains a spool; each spool is compatible with all actuations.

Example with spool 3 position double acting:

S01N Nominal flow (50 l/min)

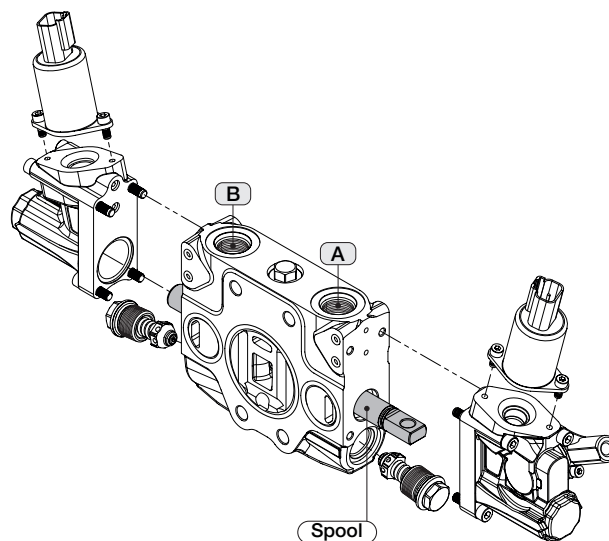

CODE	DESCRIPTION	SYMBOL
S01	Spool 3 positions double acting	
S02	Spool 3 positions double acting A/B to tank	
S03	Spool 3 positions single acting on A	
S04	Spool 3 positions single acting on B	
S05	Spool 4 positions double acting with float in 4th position	
S11	Spool 3 positions double acting A to tank - B blocked	
S12	Spool 3 positions double acting A blocked - B to tank	



Note:

S05 spool needs a special machining on the body and a special detent kit. The spools shown correspond to standard configuration, for different applications, please contact our Sales Office.

WORK SECTION

6	7	8	9	10	11	12	13
L	S 1 P 2 E 2 S	V 5 1 1 0 0	V 5 1 1 8 0	S 0 1 N	A E 0 1	R E 0 1	K 1 2 D

SPOOL ACTUATION

Spool actuations are classified in three categories:

MECHANICAL ACTUATION

- Requires the choice of spool return action (side B).
- Requires a dedicated body.

HYDRAULIC ACTUATION

- Leave out the spool return action code when choosing hydraulic actuation AH01B, AH01S, AH02B, AH02S, AH04B and AH04S.
- Requires a dedicated body.

ELECTROHYDRAULIC ACTUATION

- Requires a dedicated body.

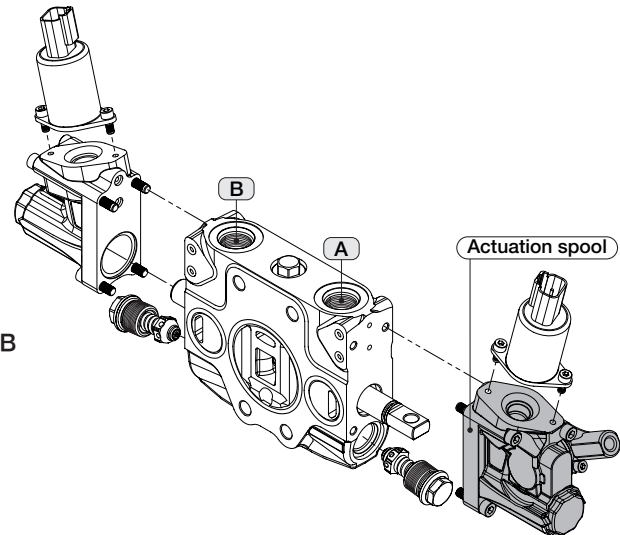

SPOOL ACTUATION - SIDE A (MECHANICAL ACTUATION)

CODE	DESCRIPTION	CONFIGURATION	SYMBOL
AM01	Control lever		
AM02	Control lever rotated 180°		
AM05	Control tang spool end Spool end thickness = 8 MM Spool end hole = Ø8 MM		
AM20	Control lever FLOAT - only with spool S05 - only with a special body		

WORK SECTION

JOYSTICK CONTROL ACTUATION

The Joystick option is made to control 2 spools at the same time with one hand. The way it can manage the flow is based on the fulcrum position so the code.

In the following table you can refer lever actuation against flow on valve ports (A/B).

Actuation code for spool without fulcrum is always **AJ00**

Note: Lever for joystick control has to be ordered separately.

CODE	DESCRIPTION	FULCRUM POSITIONS	DRAWING	ACTUATIONS
AJ1L	Joystick control LEFT SIDE INLET Fulcrum on 1 st section	First section Second section AJ00		
AJ2L	Joystick control LEFT SIDE INLET Fulcrum on 2 nd section	Second section First section AJ00		
AJ1R	Joystick control RIGHT SIDE INLET Fulcrum on 1 st section	First section Second section AJ00		
AJ2R	Joystick control RIGHT SIDE INLET Fulcrum on 2 nd section	Second section First section AJ00		

WORK SECTION

SPOOL ACTUATION - SIDE A (HYDRAULIC ACTUATION)

CODE	DESCRIPTION	CONFIGURATION	SYMBOL
AH01B	Hydraulic actuation with side ports (G 1/4)		
AH01S	Hydraulic actuation with side ports (SAE6)		
AH02B	Hydraulic actuation with upper ports (G 1/4)		
AH02S	Hydraulic actuation with upper ports (SAE6)		
AH04B	Hydraulic actuation with stroke limiter ports (G 1/4)		
AH04S	Hydraulic actuation with stroke limiter ports (SAE 6)		

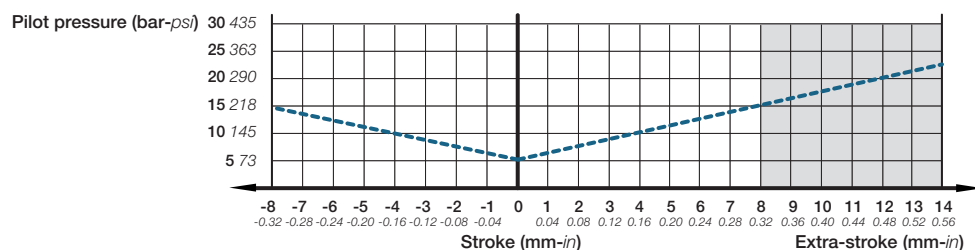
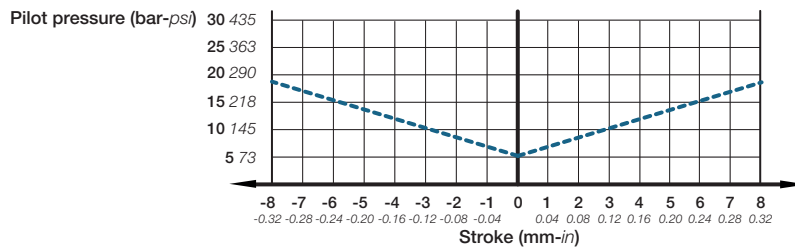

SPRING CHARACTERISTIC CURVES HYDRAULIC ACTUATION

The graph shows the spool stroke as a function of the pressure operating.

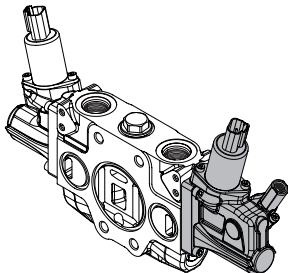
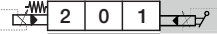
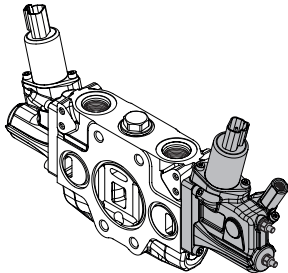
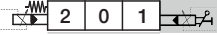
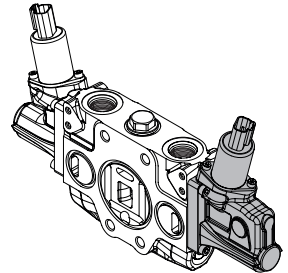
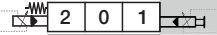
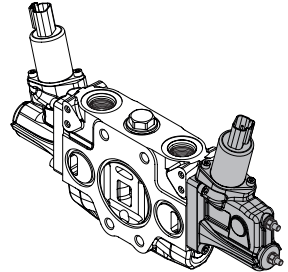

WORK SECTION

SPOOL ACTUATION - SIDE A (ELECTROHYDRAULIC ACTUATION)

CODE	DESCRIPTION	CONFIGURATION	SYMBOL
AE01	Electrohydraulic actuation with lever control		
AE02	Electrohydraulic actuation with lever control and stroke limiter		
AE03	Electrohydraulic actuation without lever control		
AE04	Electrohydraulic actuation without lever control and stroke limiter		

WORK SECTION

6	7	8	9	10	11	12	13
L	S 1 P 2 E 2 S	V 5 1 1 0 0	V 5 1 1 8 0	S 0 1 N	A E 0 1	R E 0 1	K 1 2 D

SPOOL RETURN ACTION

ECS08A spool return action are classified in two categories:

- Mechanical return action spool
- Electrohydraulic return action spool

Spool return action for mechanical actuation have three different spring types:

- **M** (medium spring)
- **S** (soft spring)
- **H** (heavy spring)

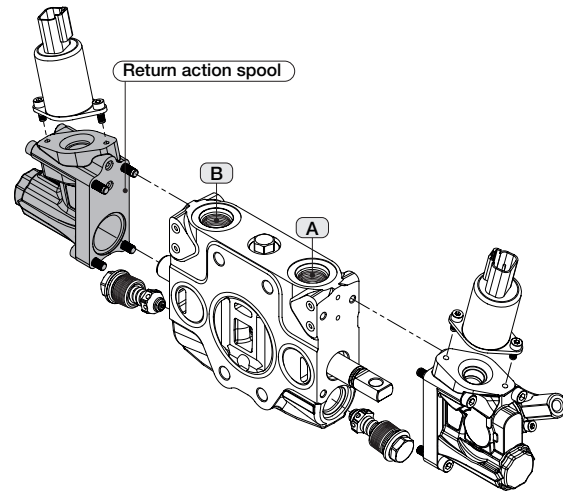

SPRING	F1 PRELOADING (N)	F2 END STROKE (N)
M (medium)	100	120
S (soft)	80	100
H (heavy)	130	170

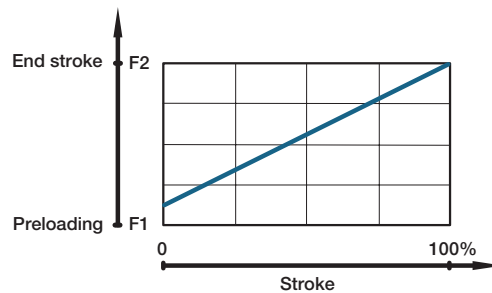

SPOOL RETURN ACTION - SIDE B (MECHANICAL ACTUATION)

CODE	DESCRIPTION	CONFIGURATION	SYMBOL
RM01M	3 position spring centered spool (MEDIUM spring)		
RM01S	3 position spring centered spool (SOFT spring)		
RM01H	3 position spring centered spool (HEAVY spring)		
RM04M	Detent in position 1/2		
RM05M	Detent in position 1		
RM06M	Detent in position 2		
RM11M	Detent in 4 th position - only with spool S05		
RM12	Detent in position 1/0/2 without spring		
RM13M	Detent in 1/0/2/4 th position - only with spool S05		

WORK SECTION

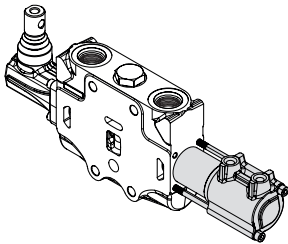
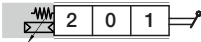
CODE	DESCRIPTION	CONFIGURATION	SYMBOL
RR01	Proportional pneumatic control (connections G 1/8)		
RR03	Proportional pneumatic control (connections NPTF 1/8-27)		

SPRING CHARACTERISTIC CURVE PNEUMATIC CONTROL

The diagram shows the spool stroke as a function of the pneumatic pressure operating.

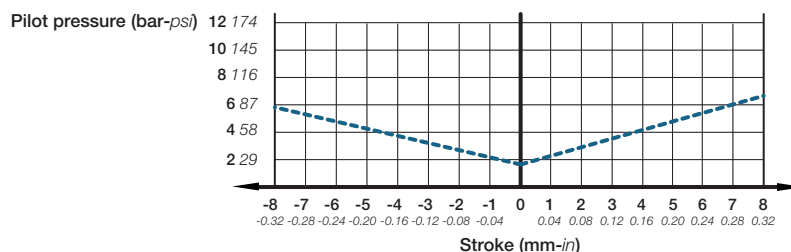

SPOOL RETURN ACTION - SIDE B (ELECTROHYDRAULIC ACTUATION)

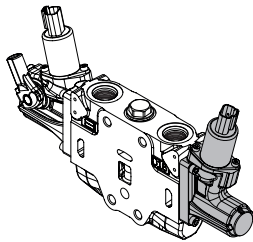
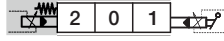
CODE	DESCRIPTION	CONFIGURATION	SYMBOL
RE01	Spool return kit for Electrohydraulic actuation <i>(only for: AE01-AE02-AE03)</i>		

WORK SECTION

6	7	8	9	10	11	12	13
L	S 1 P 2 E 2 S	V 5 1 1 0 0	V 5 1 1 8 0	S 0 1 N	A E 0 1	R E 0 1	K 1 2 D

COIL KIT

Coil kit must be ordered separately with all electrohydraulic actuators.
Each work section requires 2 coil kits.

2 coil types are available in 12 and 24 Volt versions:

- **DEUTSCH DT04**
- **AMP JUNIOR**

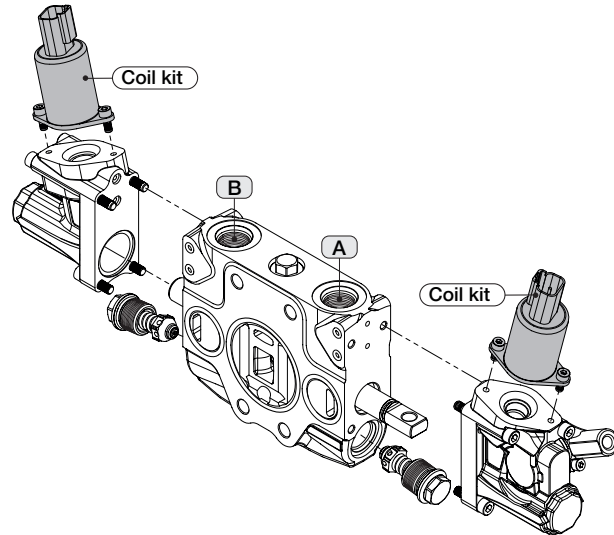

COIL AND CONNECTOR DATA

SPECIFICATIONS	K12D	K24D	K12A	K24A
Connector type	DEUTSCH DT04-2P		AMP Junior timer (AMP84-9419)	
Supply voltage	12 VDC	24 VDC	12 VDC	24 VDC
Coil resistance	4.7 Ohm ±5%	20.8 Ohm ±5%	4.7 Ohm ±5%	20.8 Ohm ±5%
Maximal current	1500±10 mA	750±10 mA	1500±10 mA	750±10 mA
PWM Frequency recommended	PWM 100 Hz			
Filter screen	125 µm			
Response time	< 50 ms			
Duty cycle	ED 100%			
Degree of protection	Deutsch IP69K		AMP IP65	
Connector color	Black		Mossy-grey	
Feeding reducing pressure	40 bar			
Max pressure on pilot tank line	5 bar			

CHARACTERISTIC CURVE CURRENT VS. PRESSURE (Less than 2% Hysteresis)

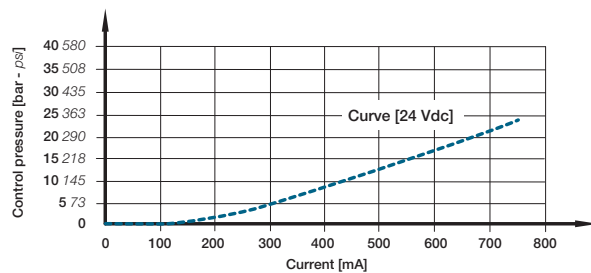
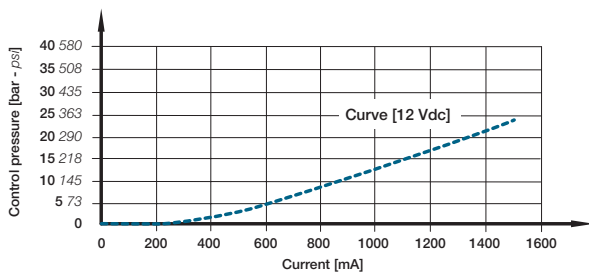

Note:

Mating connector for Deutsch DT04 is:
DT06-2S



OUTLET SECTION

14	15				
L	T	1	R	3	S

There are two main types of arrangement outlet section:

- **Outlet version with PRV**
to be used when at least one section in the directional valve has electrohydraulic actuation
- **Outlet version without PRV**
to be used when no electrohydraulic actuations are present in the directional valve

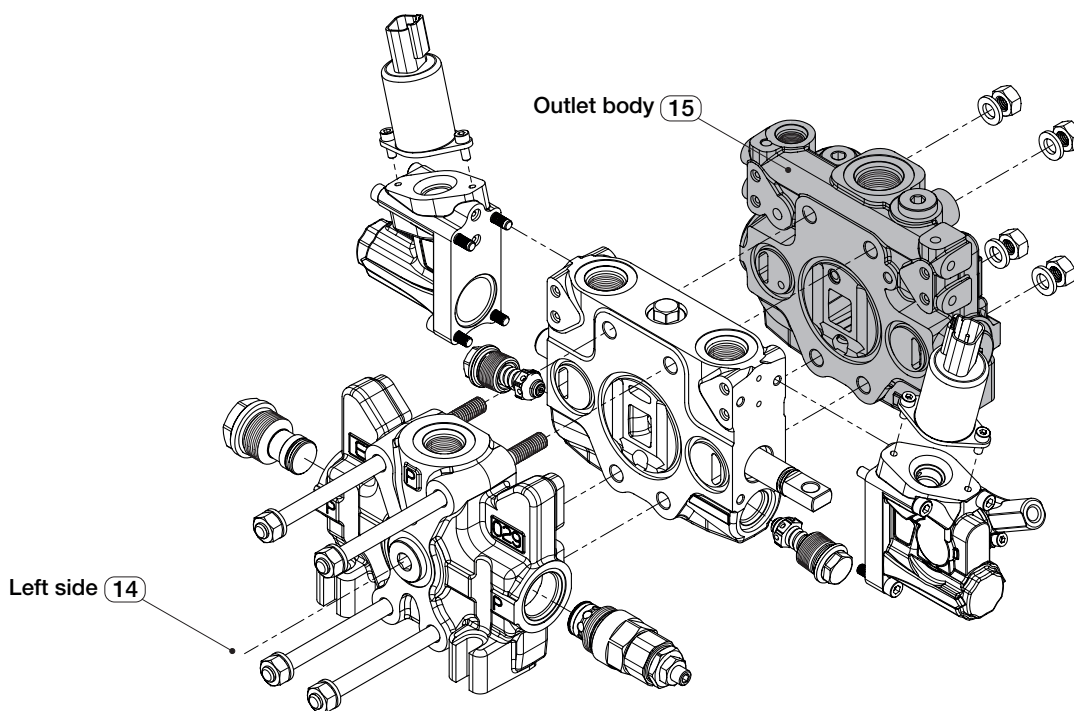

This example represents outlet section ECS08A with left configuration

- L**Left outlet side
- T1R3S**Upper outlet 7/8"-14 UNF (SAE10) with PRV

CODE	DESCRIPTION	DRAWING	DESCRIPTION	DRAWING
L	Outlet side LEFT		R	Outlet side RIGHT

Convention for all ECS08A valves with outlet right (R) or outlet left (L):

- side A = spool actuation side
- side B = spool return action side.

OUTLET SECTION

14	15				
L	T	1	R	3	S

ARRANGEMENT OUTLET BODY

ECS08A arrangement outlet body is available in two configurations: SAE thread or BSP thread. The maximum flexibility of the outlet body configuration is guaranteed by the positioning of the service ports plug. It is possible to have simple T port or two ports configuration for HPCO connection; HPCO allows to extend the by pass channel and connect a second directional valve.

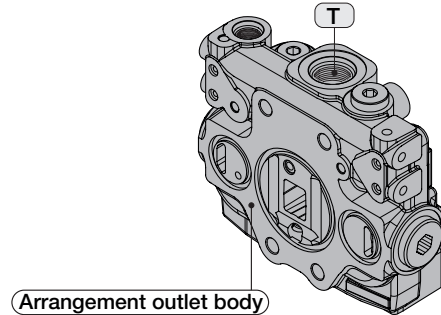

All outlet section ECS08A can be easily transformed from simple T port to HPCO configuration just by installing two conic plugs. These examples represents arrangement outlet body in left configuration for mechanical or hydraulic control.

ARRANGEMENT OUTLET SECTION simple T port

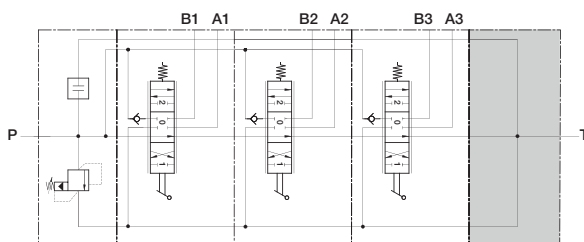
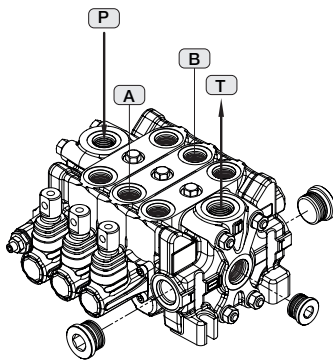

ARRANGEMENT OUTLET SECTION HPCO connection

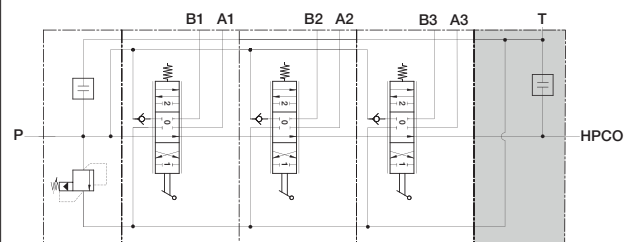
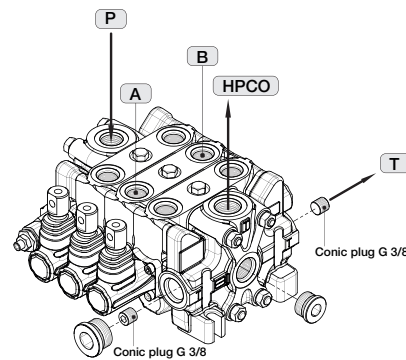

Note:

All outlet sections ECS12A for electrohydraulic configuration contain a pressure reducing valve (PRV).

We recommend to connect drain port T2 directly to tank, in order to avoid control system damages and inaccurate control.

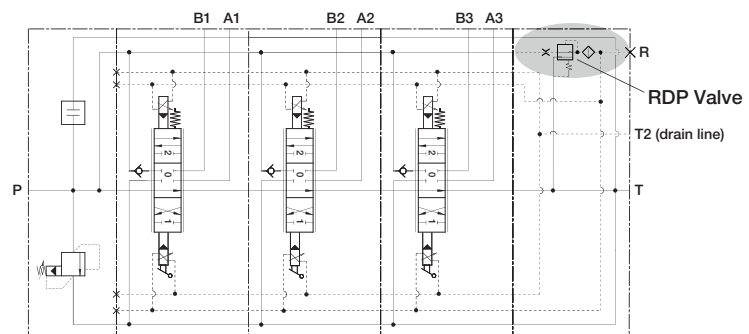

OUTLET SECTION

OUTLET CONFIGURATION FOR MECHANICAL OR HYDRAULIC CONFIGURATION (SIMPLE T PORT)

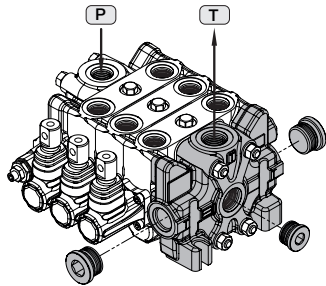
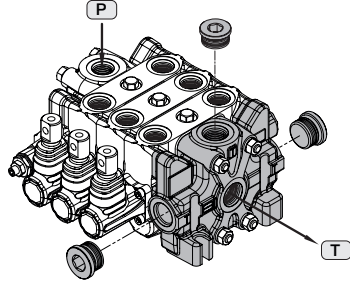
CODE	DESCRIPTION	CONFIGURATION
T13S	Upper outlet - 7/8" 14 UNF (SAE10)	
T13B	Upper outlet - G 1/2	
T23S	Central outlet - 7/8" 14 UNF (SAE10)	
T23B	Central outlet - G 1/2	

OUTLET CONFIGURATION FOR MECHANICAL OR HYDRAULIC CONFIGURATION (HPCO CONNECTION)

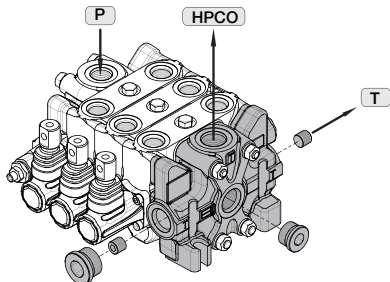
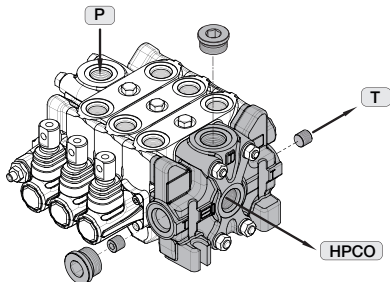
CODE	DESCRIPTION	CONFIGURATION
TH13S	HPCO Upper outlet - 7/8" 14 UNF (SAE10) T side outlet B - 7/8" 14 UNF (SAE10)	
TH13B	HPCO Upper outlet - G 1/2 T side outlet B - G 1/2	
TH23S	HPCO Central outlet - 7/8" 14 UNF (SAE10) T side outlet B - 7/8" 14 UNF (SAE10)	
TH23B	HPCO Central outlet - G 1/2 T side outlet B - G 1/2	

OUTLET SECTION

OUTLET CONFIGURATION FOR ELECTROHYDRAULIC CONFIGURATION (SIMPLE T PORT)

CODE	DESCRIPTION	CONFIGURATION
T1R3S	Upper outlet - 7/8" 14 UNF (SAE10) with PRV	
T1R3B	Upper outlet - G 1/2 with PRV	
T2R3S	Central outlet - 7/8" 14 UNF (SAE10) with PRV	
T2R3B	Central outlet - G 1/2 with PRV	

OUTLET CONFIGURATION FOR ELECTROHYDRAULIC CONFIGURATION (HPCO CONNECTION)

CODE	DESCRIPTION	CONFIGURATION
TH1R3S	HPCO Upper outlet - 7/8" 14 UNF (SAE10) T side outlet B - 7/8" 14 UNF (SAE10) with PRV	
TH1R3B	HPCO Upper outlet - G 1/2 T side outlet B - G 1/2 with PRV	
TH2R3S	HPCO Central outlet - 7/8" 14 UNF (SAE10) T side outlet B - 7/8" 14 UNF (SAE10) with PRV	
TH2R3B	HPCO Central outlet - G 1/2 T side outlet B - G 1/2 with PRV	

OUTLET SECTION

OUTLET CONFIGURATION FOR ELECTROHYDRAULIC CONFIGURATION (SIMPLE T PORT) WITH PRV AND BUILD UP PRESSURE.

For those system where the pressure at pump is lower than 9 bar, EBI can offer a build up pressure valve into the Outlet manifold able to increase the pressure at the pump inlet accordingly.

CODE	DESCRIPTION	CONFIGURATION
T3RC3S	Outlet T side A front - 7/8" 14 UNF (SAE10) with BUP <i>T2 drain: 9/16-18 UNF thread</i>	
T3RC3B	Outlet T side A front - G 1/2 with BUP <i>T2 drain: G 1/4" thread</i>	
T4RC3S	Outlet T side B rear - 7/8" 14 UNF (SAE10) with BUP <i>T2 drain: 9/16-18 UNF thread</i>	
T4RC3B	Outlet T side B rear - G 1/2 with BUP <i>T2 drain: G 1/4" thread</i>	



Note:

HPCO Outlet can not cope with BUP (Build up pressure) valve.



OPTION

PAINTING

On request all ECS08A directional control valves by EBI can be delivered painted (RAL 9005 black primer).

ORDER EXAMPLE OF ECS08A/1 PAINTED:

info	E	C	S	0	8	A	N	1	E																											
inlet	L	P	1	2	S	V	0	1	1	5	0	V	0	2																						
section	L	S	1	P	2	E	2	S	V	5	1	1	0	0	V	5	1	1	8	0	S	0	1	N	A	E	0	1	R	E	0	1	K	1	2	D
outlet	L	T	1	R	3	S																														
option	X	1																																		

X1 Painted color black

CODE	DESCRIPTION
X1	ECS08A with 1 work section painted
X2	ECS08A with 2 work sections painted
X3	ECS08A with 3 work sections painted
X4	ECS08A with 4 work sections painted
X5	ECS08A with 5 work sections painted
X6	ECS08A with 6 work sections painted
X7	ECS08A with 7 work sections painted
X8	ECS08A with 8 work sections painted
X9	ECS08A with 9 work sections painted
X10	ECS08A with 10 work sections painted
X11	ECS08A with 11 work sections painted
X12	ECS08A with 12 work sections painted

ACCESSORIES

LEVER ROD

The following table lists the lever available for the ECS08A control Valve.

CODE	DESCRIPTION	LENGHT	DRAWING	ORDER CODE
W08A	Lever rod for electrohydraulic actuation	135 mm		A01170011
W08B	Lever rod for mechanical actuation	150 mm		A01170010
W08C		210 mm		A01170008



Note:
The lever rod must be ordered separately.

GENERAL CLAMPING TORQUE

The following design provides the main tightening torques of the **INLET SECTION**

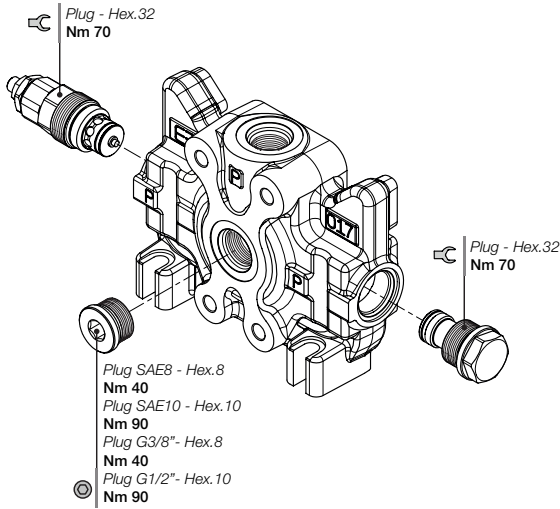

The following design provides the main tightening torques of the **OUTLET SECTION**

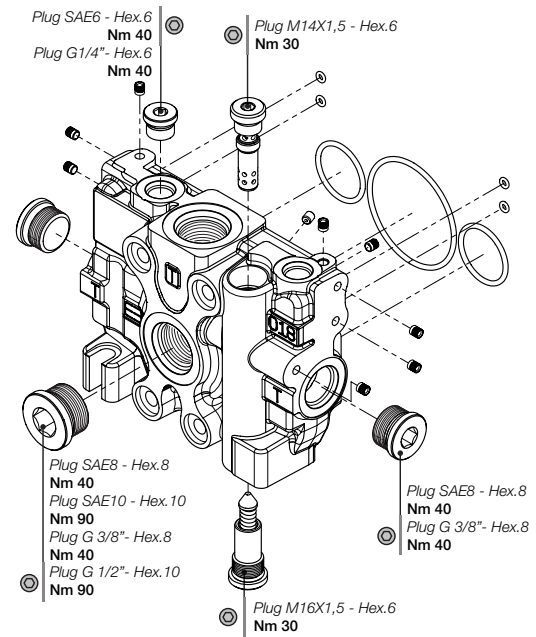

The following design provides the main tightening torques of the **WORK SECTION**

ELECTROHYDRAULIC ACTUATION

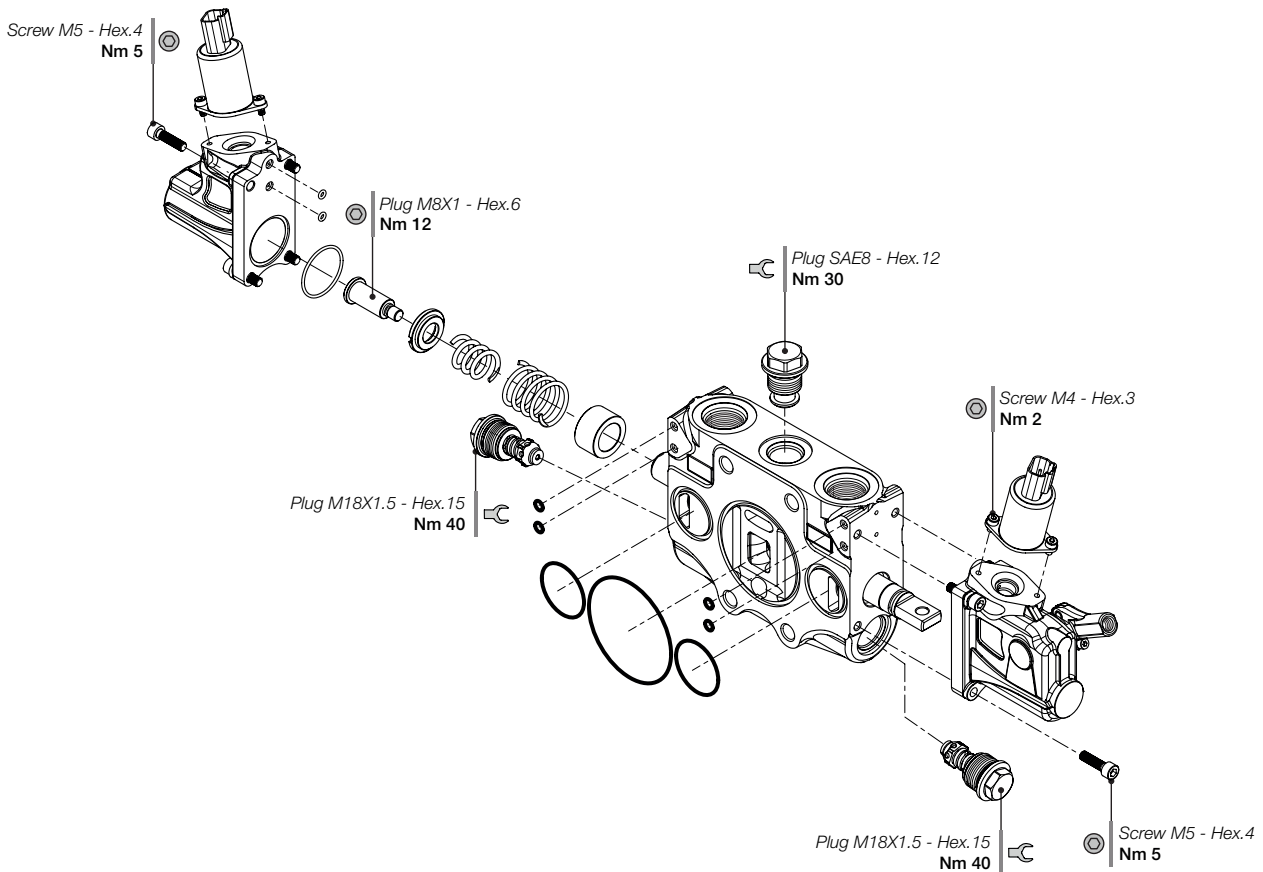

HYDRAULIC ACTUATION

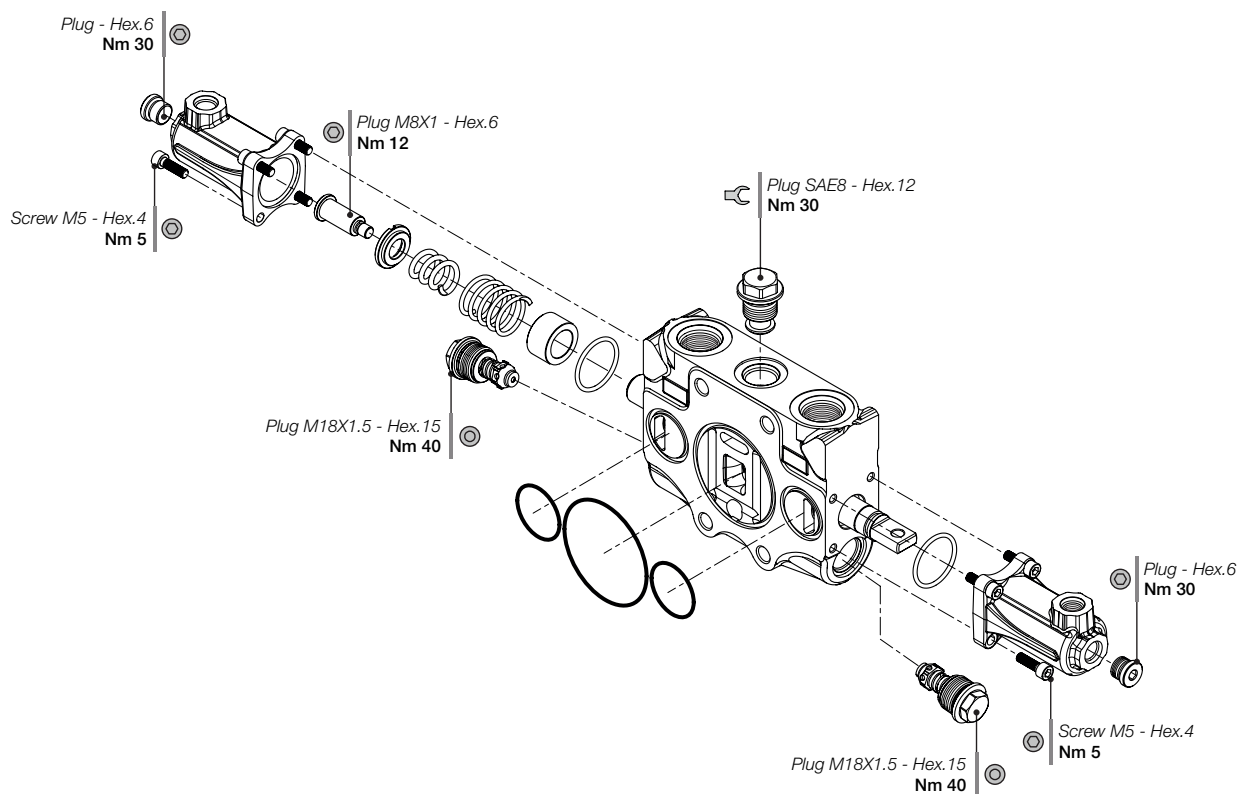

MECHANICAL ACTUATION

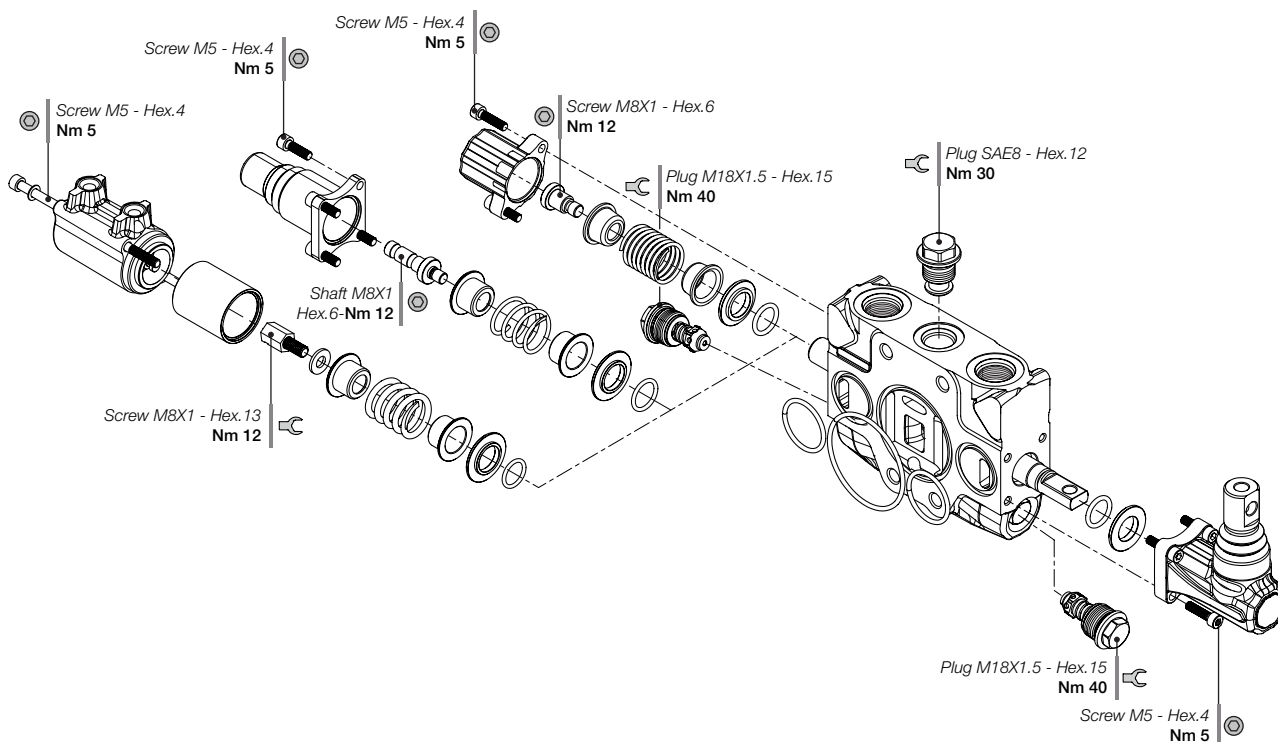

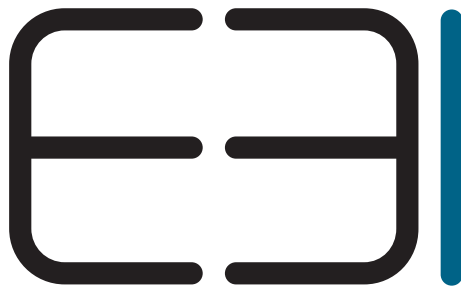

engineering beyond imagination

EBI MOTION CONTROLS S.r.l

Via Andrea Costa 11/2 40057
Cadriano Fraz. di Granarolo dell'Emilia (BO)
TEL. +39 051.0188.800
FAX 051.701.093

info@ebimc.com
www.ebimc.com